

2016

PREISLISTE

Präzisionswerkzeuge

PRICELIST

Precision Tooling System

TARIF

Porte-outils de précision



**KEMMLER**®  
Präzisionswerkzeuge

Внимание! Данный прайс-лист для европейского рынка.  
Цены в РФ значительно отличаются от цен, указанных в данном документе!  
Для получения актуальной стоимости, обращайтесь по контактам, указанным ниже.

kemmler@kemmler.su  
www.kemmler.su

**K KEMMLER®**

*Ein Unternehmen mit Geschichte und Tradition*

**KEMMLER®** Präzisionswerkzeuge GmbH, das Familienunternehmen aus der baden-württembergischen Stadt Mössingen bei Stuttgart, entwickelt, fertigt und vertreibt innovative und hochpräzise Produkte rund um die Werkzeugmaschine.

Das international tätige Unternehmen wurde 1997 von Fritz Kemmler gegründet und wird mittlerweile in zweiter Generation von Jörg und Daniel Kemmler geführt.

**K KEMMLER®**

*A company with history and tradition*

**KEMMLER®** Präzisionswerkzeuge GmbH, the family business at Mössingen near Stuttgart in Baden-Württemberg develops, manufactures and distributes innovative and high-precision products around the machine tools.

The international acting company was founded in 1997 by Fritz Kemmler and is now run by the second generation of Jörg and Daniel Kemmler.



Familienwappen seit 1396

Family crest since 1396

Blason familial dès 1396

**K KEMMLER®**

*Une entreprise plein d'histoire et de tradition*

**KEMMLER®** Präzisionswerkzeuge GmbH, une entreprise familiale située à Mössingen près de Stuttgart en Bade-Wurtemberg, développe, produit et distribue des produits innovants et précis pour machines outils.

Dès 1997 l'entreprise inaugurée par Fritz Kemmler est active dans le monde entier. Entre-temps ses fils Jörg et Daniel Kemmler ont pris en charge la direction.

Внимание! Данный прайс-лист для европейского рынка.

Цены в РФ значительно отличаются от цен, указанных в данном документе!

Для получения актуальной стоимости, обращайтесь по контактам, указанным ниже.

kemmler@kemmler.su

www.kemmler.su

## Inhaltsverzeichnis

Index

Table de matières



### Werkzeugaufnahmen DIN 69871 AD/B

*Toolholders DIN 69871 AD/B*  
Porte-outils DIN 69871 AD/B

1



### Werkzeugaufnahmen JIS B 6339 (MAS 403 BT) AD/B

*Toolholders JIS B 6339 (MAS 403 BT) AD/B*  
Porte-outils JIS B 6339 (MAS 403 BT) AD/B

2



### Werkzeugaufnahmen DIN 2080

*Toolholders DIN 2080*  
Porte-outils DIN 2080

3



### Werkzeugaufnahmen DIN 69893 / ISO 12164-1 (HSK)

*Toolholders DIN 69893 / ISO 12164-1 (HSK)*  
Porte-outils DIN 69893 / ISO 12164-1 (HSK)

4



### Werkzeugaufnahmen ISO 26623

*Toolholders ISO 26623*  
Porte-outils ISO 26623

5



### Werkzeugaufnahmen DIN 69880 (ISO 10889-1) VDI

*Toolholders DIN 69880 (ISO 10889-1) VDI*  
Porte-outils DIN 69880 (ISO 10889-1) VDI

6



### Werkzeugaufnahmen MK DIN 228-1 A und DIN 228-1 B

*Toolholders MT DIN 228-1 A and DIN 228-1 B*  
Porte-outils CM DIN 228-1 A et DIN 228-1 B

7



### Zubehör · Spannzangen · Anzugsbolzen

*Accessories · Collets · Pull studs*  
Accessoires · Pinces · Tirettes

8



### Präzisionsschraubstöcke

*Precision vices*  
Etaux de précision

9



### Messtechnik

*Measuring technique*  
Métrologie

10



Внимание! Данный прайс-лист для европейского рынка.  
Цены в РФ значительно отличаются от цен, указанных в данном документе!  
Для получения актуальной стоимости, обращайтесь по контактам, указанным ниже.

kemmler@kemmler.su  
www.kemmler.su

**KEMMLER**

01



# KEMMLER®

*Fertigung Werkzeughalter*

Vom Schmiederohling bis hin zum Endprodukt erfolgen alle Bearbeitungsprozesse unter einem Dach. Nur so kann die 100% **KEMMLER®** Qualität erreicht werden.

Mit modernstem Maschinenpark der jüngsten Generation und sehr hohem Automatisierungsgrad bei großer Fertigungstiefe werden mehr als 40.000 Werkzeughalter im Monat produziert.

# KEMMLER®

*Toolholder production*

From the forging blank to the final product all working processes take place under the same roof. Just this way the 100% **KEMMLER®** quality can be achieved.

With modern machinery of the latest generation and a very high degree of automation in a large vertical range of manufacture more than 40.000 toolholders are produced every month.

# KEMMLER®

*Fabrication de porte-outils*

De l'ébauche de forge au produit fini tous les processus d'usinage ont lieu sous le même toit.

Seulement ainsi la qualité **KEMMLER®** de 100% peut être obtenue.

Avec des machines modernes de la dernière génération et de très haut degré d'automatisation dans une large portée verticale de fabrication plus de 40.000 porte-outils sont produits par mois.

## Schmieden

*Forging*

Forger

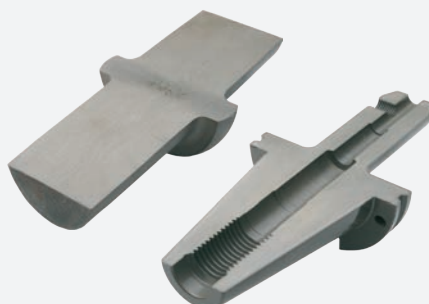

Внимание! Данный прайс-лист для европейского рынка.

Цены в РФ значительно отличаются от цен, указанных в данном документе!

Для получения актуальной стоимости, обращайтесь по контактам, указанным ниже.

[kemmler@kemmler.su](mailto:kemmler@kemmler.su)

[www.kemmler.su](http://www.kemmler.su)



## Fräsen und Drehen

Milling and Turning

Fraisage et Tournasage

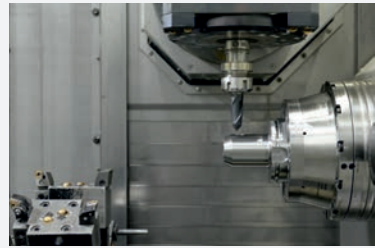
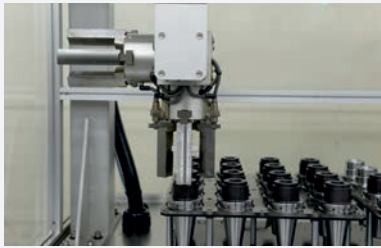
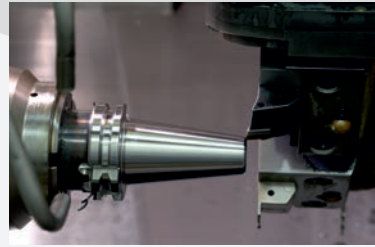
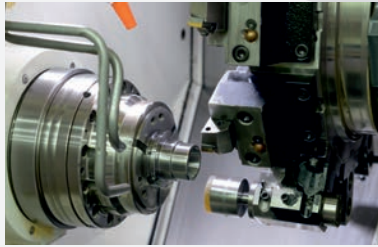
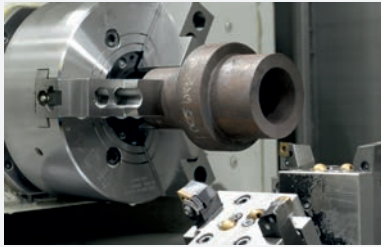

## Schleifen

Grinding

Affûtage



## Messen und Auswuchten

Measuring and Balancing

Métrieologie et Équilibrage

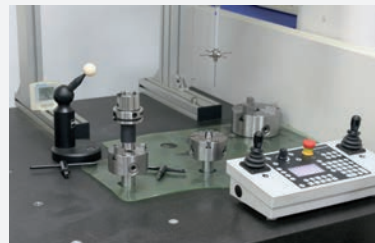
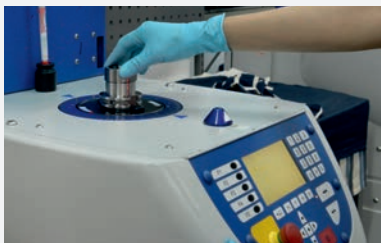

Внимание! Данный прайс-лист для европейского рынка.  
Цены в РФ значительно отличаются от цен, указанных в данном документе!  
Для получения актуальной стоимости, обращайтесь по контактам, указанным ниже.



**KEMMLER**® Präzisionswerkzeuge ist Ihr kompetenter Partner und Lieferant für qualitativ hochwertige Produkte und fertigt auf Werkzeugmaschinen der jüngsten Generation. Als Hersteller von Werkzeugaufnahmen hat sich das mehrsprachige Unternehmen aufgrund hoher Innovationsfreude und einem überdurchschnittlichen Qualitätsniveau vor Jahren am nationalen und internationalen Markt etabliert.

Der Vertrieb der Produkte erfolgt über die führenden Handelshäuser, Werkzeughersteller, namhaften Erstausrüster und den einschlägigen Fachhandel.

**KEMMLER**® steht für höchste Präzision in Perfektion, Zuverlässigkeit sowie Qualität und kann damit seine Produkte in besonders anspruchsvollen Branchen zum Einsatz bringen: Luft- und Raumfahrt, Maschinenbau, Medizintechnik und Automobilindustrie.



**KEMMLER**® Präzisionswerkzeuge is your professional partner and supplier for high quality products and manufactures with machine tools of the latest generation. As a manufacturer of tool holders, the multilingual business has established on the national and international market since years due to high innovation and an above-average quality level.

The products distribution takes place via leading retail companies, tool manufacturer, original equipment manufacturers and the specialist shops.

**KEMMLER**® stands for high-precision in perfection, reliability as well as quality and can thus bring its products to ambitious industries: aerospace, engineering, medical technology and the automotive industry.



**KEMMLER**® Präzisionswerkzeuge est votre partenaire et fournisseur compétent pour des produits de haute qualité fabriqués sur machines innovatrices. En tant que producteur de porte-outils notre entreprise plurilingue s'est établie sur le marché national et international grâce à innovations permanentes et une qualité de haut niveau.

La distribution des produits s'effectue par maisons de commerce, fournisseurs d'outils, OEM connus et le commerce spécialisé.

**KEMMLER**® garantit haute precision, fiabilité et qualité ce qui permet l'emploi de nos produits dans des branches exigeantes – aéronautique et astronautique, construction de machines, technologie médicale et l'industrie automobile.

Внимание! Данный прайс-лист для европейского рынка.  
Цены в РФ значительно отличаются от цен, указанных в данном документе!  
Для получения актуальной стоимости, обращайтесь по контактам, указанным ниже

kemmler@kemmler.su  
www.kemmler.su





First Class<sup>®</sup> ist ein eingetragenes Warenzeichen der Kemmler Präzisionswerkzeuge GmbH. Ein Gütesiegel das Präzision, Qualität, Zuverlässigkeit und hervorragenden Service symbolisiert.

*First Class<sup>®</sup> is a licenced trade mark of Kemmler Präzisionswerkzeuge GmbH. A grade standing for precision, quality, reliability and top class service.*

First Class<sup>®</sup> est une marque déposée de Kemmler Präzisionswerkzeuge GmbH. Une marque qui représente la précision, qualité, fiabilité et un service extraordinaire.



Внимание! Данный прайс-лист для европейского рынка.  
Цены в РФ значительно отличаются от цен, указанных в данном документе!  
Для получения актуальной стоимости, обращайтесь по контактам, указанным ниже.

[kemmler@kemmler.su](mailto:kemmler@kemmler.su)  
[www.kemmler.su](http://www.kemmler.su)







**KEMMLER®** steht nicht nur für Präzision und Qualität bei der Herstellung von Werkzeugaufnahmen, sondern wir wünschen uns vor allem, dass Sie sich wohl fühlen und bieten Ihnen einen erstklassigen Rundum-Service.



**SIE BESTELLEN – WIR LIEFERN**

**KEMMLER®** möchte seinen Kunden lange Wartezeiten auf bestellte Ware ersparen. Daher sind rund 98% der **KEMMLER®**-Produkte sofort ab Lager lieferbar. Zudem können Sie als Kunde jederzeit online die Lieferverfügbarkeit abrufen – einfach einloggen, die gewünschte Ware abrufen und bestellen.



**KEMMLER®** not only stands for precision and quality in the manufacture of tool-holders, but our aim is to make you feel comfortable and therefore we offer you a first class all round service.



**YOU ORDER – WE DELIVER**

**KEMMLER®** minimizes delivery time for ordered goods. Therefore 98% of all **KEMMLER®**-products are available ex-stock. As a registered customer you can check the availability of the products anytime by online access – just log in, retrieve the desired goods and place the order.



**KEMMLER®** ne signifie pas seulement précision et qualité au niveau de nos produits. Nous tenons surtout à votre contentement et nous nous efforçons à vous offrir un service complet.



**VOUS COMMANDEZ – NOUS EXPÉDIONS**

**KEMMLER®** réduit de longs délais. 98% des produits Kemmler sont en stock. Sur notre site nos clients peuvent vérifier si l'article demandé est disponible – tout simplement se connecter sur internet et passer la commande.

Внимание! Данный прайс-лист для европейского рынка.  
Цены в РФ значительно отличаются от цен, указанных в данном документе!  
Для получения актуальной стоимости, обращайтесь по контактам, указанным ниже.

kemmler@kemmler.su  
www.kemmler.su





### KEMMLER® WELTWEIT

Als Unternehmen mit internationaler Ausrichtung möchten wir auf die Bedürfnisse unserer Kunden weltweit eingehen: mit persönlicher und kompetenter Fachberatung, der Unterstützung unseres mehrsprachigen Teams und umfassenden, dreisprachigen Produktkatalogen sind wir für Sie da.

Darf es etwas mehr sein?

Sie benötigen spezielle Werkzeuge? Wir stellen uns jeder Herausforderung und fertigen für Sie kurzfristig Sonderwerkzeuge nach Wunsch und liefern innerhalb weniger Wochen.



### KEMMLER® WORLDWIDE

*As a company with international focus, we want to commit to the needs of our worldwide customers: with personal and competent technical advice, the support of our multilingual team and comprehensive, trilingual product catalogues, we are ready to attend you.*

*Any additional requirements?*

*You need special tools? We accept every challenge and finish special tools according to your wishes and deliver within few weeks.*



### KEMMLER® AUTOUR DU MONDE

Comme entreprise à orientation internationale notre objectif est de répondre aux besoins de nos clients dans le monde entier: par une consultation individuelle de notre personnel plurilingue et qualifié et des catalogues détaillés trilingues.

Vous avez un besoin en plus?

Il vous faut des outils spéciaux? Nous acceptons le défi et fabriquons des porte-outils spéciaux sur demande à court terme.



### SCHNELLER SERVICE

Wir garantieren Ihnen eine zügige und reibungslose Bestellabwicklung. Wir bearbeiten Ihre Kundenanfragen direkt und verschicken die Ware noch am selben Tag an Sie oder ihren Kunden. Neben einer schnellen Abwicklung erhalten Sie zusätzlich eine Versandbestätigung per E-Mail und können Ihre Bestellung nachverfolgen. Bei Bestellungen aus dem Ausland übernimmt **KEMMLER®** die Zollformalitäten.



### RAPID SERVICE

*We guarantee a fast and smooth order processing. We execute your customer inquiries directly and send the goods the same day to you or your customer. In addition to a quick execution you will receive a shipping confirmation by e-mail and you will be able to track your order online. For orders from foreign countries **KEMMLER®** procures the incurring customs formalities.*



### SERVICE RAPIDE

Nous garantissons un déroulement vite et sans difficulté. Nous traitons les commandes de vos clients et expédions la marchandise le même jour directement à votre clientèle bien sûr en emballage neutre. La preuve d'expédition vous parvient par mail et vous permet de suivre le transport. **KEMMLER®** s'occupe des formalités douanières si nécessaire.



Внимание! Данный прайс-лист для европейского рынка.  
Цены в РФ значительно отличаются от цен, указанных в данном документе!  
Для получения актуальной стоимости, обращайтесь по контактам, указанным ниже.

**100% GEPRÜFTE KEMMLER® QUALITÄT**  
Wer hohe Ansprüche hat, kann sich keine Kompromisse erlauben.  
Deshalb fertigt Kemmler leistungsstarke Werkzeuge für optimale Zerspanungsprozesse.

- Sämtliche Aufnahmen werden aus geschmiedetem Stahl gefertigt
- Spezifisch, verzugsarm gehärtet
- Oberflächenhärte HRC 60 ± 2
- Härtetiefe 0,8 mm ± 0,2 mm
- Brüniert und präzisionsgeschliffen
- Kegelwinkeltoleranz < AT 3 nach DIN 7187 und DIN 2080
- Max. Rundlauffehler kleiner als 0,003 mm
- Oberflächenrauigkeit Rz kleiner als 0,5 µ
- Zugfestigkeit im Kern von min. 1200 N/mm<sup>2</sup>
- Standardmäßig dynamisch gewuchtet auf G 6,3 / 15.000 U/min

- Wir liefern Qualität auf höchstem Niveau
- 100 % Qualitätssicherung
- Unschlagbares Preis-Leistungs-Verhältnis
- Katalogwerkzeuge ab Lager lieferbar
- Sonderwerkzeuge kurzfristig innerhalb weniger Wochen
- Qualitätsmanagement nach DIN EN ISO 9001
- Umweltmanagement nach DIN EN ISO 14001
- Qualitätsmanagement nach ISO / TS 16949



Внимание! Данный прайс-лист для европейского рынка.

Цены в РФ значительно отличаются от цен, указанных в данном документе!

Для получения актуальной стоимости, обращайтесь по контактам, указанным ниже.



**100% CERTIFICATED KEMMLER® QUALITY**

*Who has high claims cannot afford to make compromises.*

*Therefore Kemmler manufactures powerful tools for ideal machining processes.*



- All holders are made of forged steel
- Specific, low warpage hardened
- Surface hardened HRC 60 ± 2
- Hardening depth 0,8 mm ± 0,2 mm
- Black-finished and precisionground
- Taper angle tolerance < AT 3 according to DIN 7187 and DIN 2080
- Max. runout less than 0,003 mm
- Surface roughness Rz less than 0,5 µ
- Tensile strength in the core of min. 1200 N/mm<sup>2</sup>
- Dynamically balanced by default G 6,3 / 15.000 U/min

- We deliver quality at the highest level
- 100 % quality control
- Unbeatable ratio price-performance
- Catalogue tools available ex-stock
- Special tools shortly available within a few weeks
- Quality management according to DIN EN ISO 9001
- Environment management according to DIN EN ISO 14001
- Quality management according to ISO / TS 16949



**QUALITÉ KEMMLER® ÉPROUVÉ A 100 %**

*Ce qui a des exigences élevés ne peut pas accepter des compromis. Kemmler produit des porte-outils performants pour usinage optimal.*

- Tous les porte-outils sont fabriqués d'acier forge
- Trempé spécifiquement, déformation minimale
- Rigueur superficielle HRC 60± 2
- Profondeur trempée 0,8 mm ± 2 mm
- Bruni et rectifié précisément
- Tolerance angle du cône < AT 3 selon DIN 7187 et DIN 2080
- Erreur de concentricité max. < 0,003 mm
- Rugosité de la surface Rz < 0,5 µ
- Résistance à la traction au moins 1200 N/mm<sup>2</sup>
- Equilibrage dynamique standard G 6,3 / 15.000 t/min

- Nous fournissons une qualité de haut niveau
- 100 % d'assurance qualité
- Rapport prix-performance imbattable
- Porte-outils „standard“ en stock
- Porte-outils spéciaux à court terme
- Contrôle de qualité selon DIN EN ISO 9001
- Management environnemental DIN EN ISO 14001
- Contrôle de qualité selon ISO / TS 16949

**Внимание! Данный прайс-лист для европейского рынка.**  
Цены в РФ значительно отличаются от цен, указанных в данном документе!  
Для получения актуальной стоимости, обращайтесь по контактам, указанным ниже.

kemmler@kemmler.su  
www.kemmler.su



**KEMMLER®**  
**Qualitätsmanagement**  
 Quality management  
 Management de la qualité



**ISO / TS 16949**  
**Qualitätsmanagementsystem für die Automobilindustrie**

Als eines der ersten deutschen Unternehmen unserer Branche wurden wir nach der neuen Automobil-Qualitätssicherungsnorm ISO/TS 16949 zertifiziert. Damit ist der derzeit weltweit höchste erreichbare Qualitätsstandard zertifiziert worden.

Diese Zertifizierung nach ISO/TS 16949 ergänzt unser bereits seit vielen Jahren eingerichtetes Qualitätssicherungssystem nach DIN/ISO 9001/9002. Wir hatten uns zur Zertifizierung entschieden, da für ein Produktionsunternehmen unserer Branche eine Qualitätssicherungsnorm nicht wie bei den bisherigen Normen auf den Herstellungs- und Prüfungsaspekt der Produkte beschränkt. Sie ist vielmehr ein gesamtunternehmerischer Ansatz, der u.a. das Managementsystem, die Technologie, die Wettbewerbsfähigkeit sowie den Arbeits- und Umweltschutz des Unternehmens einer sehr kritischen Überprüfung und Bewertung unterzieht.

Mit dem Erreichen der ISO/TS 16949 Zertifizierung sehen wir eine Steigerung unserer Leistungsfähigkeit und Verantwortung, die Kundenforderungen qualitätsgerecht und gezielt umzusetzen. Wir überprüfen unsere Kundenorientierung nicht nur, indem wir das Ohr am Kunden haben, sondern auch durch Bewertung der Kundenzufriedenheit und der internen Kunden-Lieferanten-Beziehungen in unserem Unternehmen. Benchmarking und die Optimierung unserer Prozesse sind Schlüsselfunktionen für weitere Meilensteine unseres Erfolges.



**ISO / TS 16949**  
**Quality management system for the automobile industry**

*As one of the first German companies within our branch we have been certified according to the latest quality assurance standard of the automobile industry, ISO/TS 16949. Thus, we have been attested with the highest attainable worldwide quality standard.*

*This certificate according to ISO/TS 16949 supplements our quality assurance system as described in DIN/ISO 9001/9002, which we established many years ago. Our decision to obtain quality certification is based on the fact that for a producing company independent quality assurance is almost a predetermined prerequisite. In this regard, the ISO/TS 16949 was considered to be the ideal level of measure because the quality assurance standard is not, as in the case of other previously used standards, restricted to manufacturing and examination aspects of our products. In essence, it forms a complete industrial basis including the management system, technology, competitiveness as well as labour and environmental protection, thus providing a critical examination and evaluation.*

*Our successful acquisition of the certification according to ISO/TS 16949 increases our productivity and potential to implement customer requirements in a qualitative and effective fashion. We review our customer orientation not only by keeping close touch with their needs but also by evaluating customer satisfaction and the relationship between customers and suppliers within our company. Setting benchmarks and optimising internal processes are key indicators for further milestones of our success.*



**ISO / TS 16949**  
**Système de gestion de qualité pour l'industrie automobile**

Comme une de premières entreprises allemandes dans notre branche nous sommes été certifiées d'après le plus nouveau standard de l'assurance de qualité dans le secteur automobile, ISO/TS 16949. Par cela, nous sommes aussi été certifiés avec un standard de qualité actuellement le plus haut qui existe dans le monde entier.

Ce certificat d'après ISO/TS 16949 complète notre système d'assurance de qualité d'après DIN/ISO 9001/9002 qui a été implanté avant plusieurs ans. Nous avons décidé d'être certifié, parce que pour une entreprise produisant une certification de qualité est presque une supposition inaliénable dans notre branche. L' ISO/TS 16949 a été le bon critère, parce que ce standard d'assurance de qualité ne se limite pas à l'aspect de la production et vérification de nos produits, comme c'était le cas chez des standards précédents. Elle est plutôt un fondement industriel complet, qui inclut le système de gestion, technologie, compétitivité ainsi que protection de l'emploi et de l'environnement, donc fournissant une vérification et évaluation très solide.

Notre acquisition du certificat d'après ISO/TS 16949 élève notre productivité et potentiel de réaliser des demandes de nos clients dans une manière qualitative et effective. Nous vérifions l'orientation de nos clients ne pas seulement par nous aligner sur leurs demandes, mais aussi par évaluer leur satisfaction et la relation entre clients et fournisseurs dans notre société. Benchmarking et l'optimisation de nos procès sont les indicateurs décisifs pour des jalons supplémentaires de notre succès.

**Внимание! Данный прайс-лист для европейского рынка.**

**Цены в РФ значительно отличаются от цен, указанных в данном документе!**

**Для получения актуальной стоимости, обращайтесь по контактам, указанным ниже.**



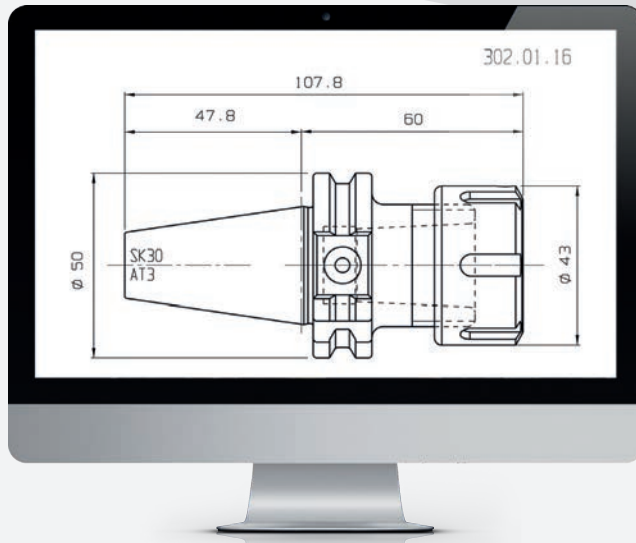

Technische Datenblätter, STEP-/STL-Modelle für die Simulation der NC-Programme und DXF-Zeichnungen zur Erstellung des Einrichteblattes stehen Online zur Verfügung.

*Technical data sheets, STEP / STL models for the simulation of NC programs and DXF drawings to create the tooling sheet are online available.*

Fiches techniques, STEP/STL modèles techniques pour la simulation de programmes CN et dessins DXF pour créer la feuille d'installation sont disponible online.

Sie können unsere Kataloge entweder direkt im Browser betrachten oder Sie auf Ihren PC, Smartphone oder Tablet herunterladen (PDF-Reader notwendig).

*You can view our catalogues either directly in the browser or download to your PC, smartphone or tablet (PDF reader required).*

Vous pouvez consulter nos catalogues directement dans le navigateur ou télécharger sur votre PC, smartphone ou tablet (lecteur PDF requis).



Auf unserer Internetseite können Sie auch die Lagerverfügbarkeit prüfen.

*On our website you can also check the stock availability.*

Sur notre site internet vous pouvez également vérifier la disponibilité du stock.

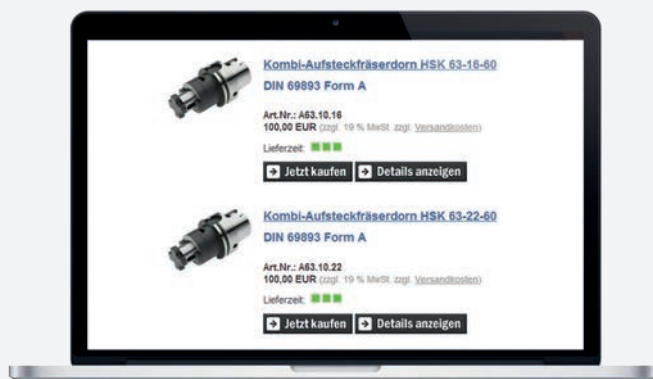

**Внимание! Данный прайс-лист для европейского рынка.**  
Цены в РФ значительно отличаются от цен, указанных в данном документе!  
Для получения актуальной стоимости, обращайтесь по контактам, указанным ниже.



## Werkzeugaufnahmen DIN 69871

Toolholders DIN 69871

Porte-outils DIN 69871



Vorgewuchtet  
Pre-balanced  
Pré-équilibré

G 6,3 15.000 min<sup>-1</sup>

G 2,5 Feinwuchten gegen Aufpreis  
G 2,5 Fine balancing at extra charge  
G 2,5 Equilibrage fin contre un supplément

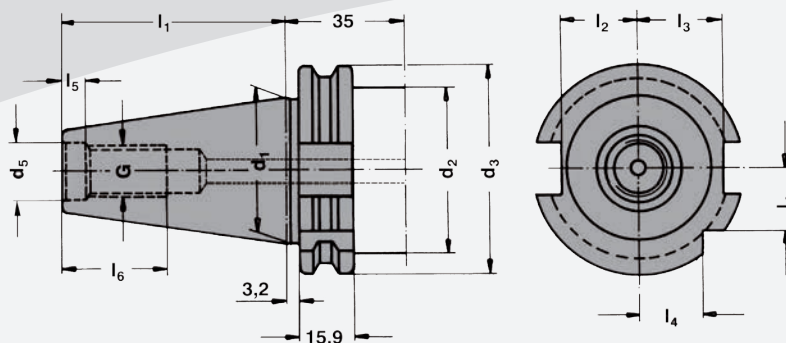

SK	d <sub>1</sub>	G	d <sub>5</sub>	d <sub>2</sub>	d <sub>3</sub>	l <sub>1</sub>	l <sub>2</sub>	l <sub>3</sub>	l <sub>4</sub>	l <sub>5</sub>	l <sub>6</sub>	d <sub>6</sub>	e
30	31,75	M12	13	45	50,00	47,80	16,4	19,0	15,0	5,5	24	M4	21
40	44,45	M16	17	50	63,55	68,40	22,8	25,0	18,5	8,2	32	M4	27
50	69,85	M24	25	80	97,50	101,75	35,5	37,7	30,0	11,5	47	M6	42

### Mit innerer Kühlmittelzufuhr über den Bund - Form AD/B

With internal coolant through the collar - form AD/B

Avec arrosage interne par la collerette - forme AD/B

Bei Lieferung mit Gewindestiften verschlossen  
Delivery with headless screws in closed position  
Livraison en état fermé avec de vis sans tête

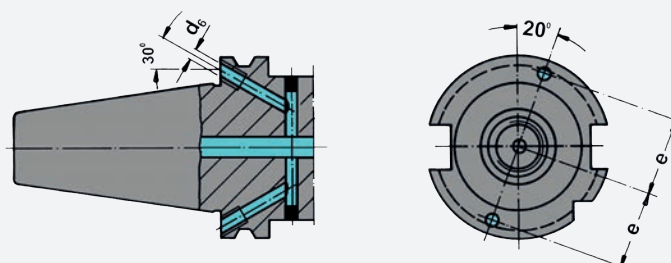

**Werkstoff:** Legierter Einsatzstahl mit einer Zugfestigkeit im Kern von min. 1200 N / mm<sup>2</sup>. Einsatzgehärtet HRC 60 ± 2 (HV 700 ± 50), Härtetiefe 0,8 mm ± 0,2 mm, brüniert und präzisionsgeschliffen.

**Form AD/B:** Lieferung in Ausführung AD, Form B mit lösbaren Gewindestiften verschlossen.

**Genauigkeit:** Kegelwinkel – Toleranzqualität < AT 3 nach DIN 7187 und DIN 2080.

**Material:** Alloyed case-hardened steel, tensile core strength of min. 1200 N / mm<sup>2</sup>. Case hardened HRC 60 ± 2 (HV 700 ± 50), hardening depth 0.8 mm ± 0.2 mm, black-finished and precisely grinded.

**Form AD/B:** Delivery in form AD, type B closed with releasable headless screws.

**Accuracy:** Quality of taper < AT 3 according to DIN 7187 and DIN 2080.

**Matière:** Acier de cémentation allié. Résistance à la traction dans le noyau de min 1200 N / mm<sup>2</sup>. Cémentation à HRC 60 ± 2 (HV 700 ± 50), profondeur de cémentation 0,8 mm ± 0,2 mm, bruni et rectifié précisément.

**Forme AD/B:** Livraison en forme AD, forme B fermée avec de vis sans tête amovibles.

**Précision:** Qualité du cône < AT 3 selon DIN 7187 et DIN 2080.

Внимание! Данный прайс-лист для европейского рынка.

Цены в РФ значительно отличаются от цен, указанных в данном документе!

Для получения актуальной стоимости, обращайтесь по контактам, указанным ниже.

# Inhaltsverzeichnis

Index

Table de matières



Внимание! Данный прайс-лист для европейского рынка.  
 Цены в РФ значительно отличаются от цен, указанных в данном документе!  
 Для получения актуальной стоимости, обращайтесь по контактам, указанным ниже.

kemmler@kemmler.su  
 www.kemmler.su

**KEMMLER**



## Werkzeugaufnahmen DIN 69871

Toolholders DIN 69871

Porte-outils DIN 69871



### Spannfutter für Spannzangen DIN 6499 (ISO 15488) System ER

Collet chucks for collets DIN 6499  
(ISO 15488) ER-system

Mandrins à pinces pour pinces DIN  
6499 (ISO 15488) système ER

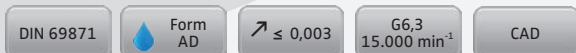

Bestell-Nr. Order no. / Réf.	Abmessung Size / Dimension	Euro
402.02.10	SK 40 - 1 / 10 - 63 ER 16	46,00
402.02.13	SK 40 - 2 / 13 - 70 ER 20	46,00
402.02.16	SK 40 - 2 / 16 - 60 ER 25	46,00
402.02.20	SK 40 - 2 / 20 - 70 ER 32	48,00
402.02.26	SK 40 - 3 / 26 - 80 ER 40	51,00
402.02.10.1	SK 40 - 1 / 10 - 100 ER 16	52,00
402.02.13.1	SK 40 - 2 / 13 - 100 ER 20	58,00
402.02.16.1	SK 40 - 2 / 16 - 100 ER 25	58,00
402.02.20.1	SK 40 - 2 / 20 - 100 ER 32	58,00
402.02.26.1	SK 40 - 3 / 26 - 100 ER 40	66,00



### Spannfutter DIN 6391 für Spannzangen DIN 6388 (ISO 10897) System OZ

Collet chucks DIN 6391 for collets  
DIN 6388 (ISO 10897) OZ-system

Mandrins à pinces DIN 6391  
pour pinces DIN 6388 (ISO 10897)  
système OZ

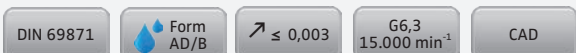

Bestell-Nr. Order no. / Réf.	Abmessung Size / Dimension	Euro
302.01.16*	SK 30 - 2 / 16 - 60 OZ 16	59,00
302.01.25*	SK 30 - 2 / 25 - 80 OZ 25	60,00
403.01.16	SK 40 - 2 / 16 - 70 OZ 16	59,00
403.01.25	SK 40 - 2 / 25 - 70 OZ 25	60,00
403.01.32	SK 40 - 3 / 32 - 90 OZ 32	63,00
403.01.16.1	SK 40 - 2 / 16 - 100 OZ 16	73,00
403.01.25.1	SK 40 - 2 / 25 - 100 OZ 25	73,00
503.01.25	SK 50 - 2 / 25 - 70 OZ 25	83,00
503.01.32	SK 50 - 3 / 32 - 80 OZ 32	88,00
503.01.32.1	SK 50 - 3 / 32 - 100 OZ 32	102,00

\* Form AD | \* Form AD | \* Forme AD



### Spannfutter für Spannzangen DIN 6499 (ISO 15488) System ER

Collet chucks for collets DIN 6499  
(ISO 15488) ER-system

Mandrins à pinces pour pinces  
DIN 6499 (ISO 15488) système ER

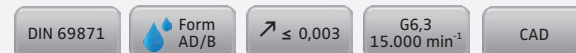

Bestell-Nr. Order no. / Réf.	Abmessung Size / Dimension	Euro
302.02.10*	SK 30 - 1 / 10 - 70 ER 16	48,00
302.02.13*	SK 30 - 2 / 13 - 70 ER 20	48,00
302.02.16*	SK 30 - 2 / 16 - 70 ER 25	48,00
302.02.20*	SK 30 - 2 / 20 - 70 ER 32	50,00
302.02.26*	SK 30 - 3 / 26 - 70 ER 40	53,00
302.02.10.1*	SK 30 - 1 / 10 - 100 ER 16	54,00
302.02.13.1*	SK 30 - 2 / 13 - 100 ER 20	60,00
302.02.16.1*	SK 30 - 2 / 16 - 100 ER 25	60,00
302.02.20.1*	SK 30 - 2 / 20 - 100 ER 32	60,00
403.02.10	SK 40 - 1 / 10 - 63 ER 16	48,00
403.02.13	SK 40 - 2 / 13 - 70 ER 20	48,00
403.02.16	SK 40 - 2 / 16 - 60 ER 25	48,00
403.02.20	SK 40 - 2 / 20 - 70 ER 32	50,00
403.02.26	SK 40 - 3 / 26 - 80 ER 40	53,00
403.02.10.1	SK 40 - 1 / 10 - 100 ER 16	54,00
403.02.13.1	SK 40 - 2 / 13 - 100 ER 20	60,00
403.02.16.1	SK 40 - 2 / 16 - 100 ER 25	60,00
403.02.20.1	SK 40 - 2 / 20 - 100 ER 32	60,00
403.02.26.1	SK 40 - 3 / 26 - 100 ER 40	67,00
403.02.10.2	SK 40 - 1 / 10 - 160 ER 16	90,00
403.02.13.2	SK 40 - 2 / 13 - 160 ER 20	90,00
403.02.16.2	SK 40 - 2 / 16 - 160 ER 25	90,00
403.02.20.2	SK 40 - 2 / 20 - 160 ER 32	92,00
403.02.26.2	SK 40 - 3 / 26 - 160 ER 40	97,00
403.02.10.3	SK 40 - 1 / 10 - 200 ER 16	133,00
403.02.13.3	SK 40 - 2 / 13 - 200 ER 20	133,00
403.02.16.3	SK 40 - 2 / 16 - 200 ER 25	133,00
403.02.20.3	SK 40 - 2 / 20 - 200 ER 32	137,00
403.02.26.3	SK 40 - 3 / 26 - 200 ER 40	146,00

\* Form AD | \* Form AD | \* Forme AD



Внимание! Данный прайс-лист для европейского рынка.

Цены в РФ значительно отличаются от цен, указанных в данном документе!

Для получения актуальной стоимости, обращайтесь по контактам, указанным ниже.

kemmler@kemmler.su  
www.kemmler.su



## Werkzeugaufnahmen DIN 69871

Toolholders DIN 69871

Porte-outils DIN 69871



**Spannfutter für Spannzangen  
DIN 6499 (ISO 15488) System ER**  
Collet chucks for collets DIN 6499  
(ISO 15488) ER-system  
Mandrins à pinces pour pinces  
DIN 6499 (ISO 15488) système ER

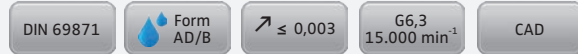

Bestell-Nr. Order no. / Réf.	Abmessung Size / Dimension	Euro
503.02.10	SK 50 - 1 / 10 - 70 ER 16	77,00
503.02.13	SK 50 - 2 / 13 - 70 ER 20	77,00
503.02.16	SK 50 - 2 / 16 - 60 ER 25	73,00
503.02.20	SK 50 - 2 / 20 - 70 ER 32	77,00
503.02.26	SK 50 - 3 / 26 - 80 ER 40	77,00
503.02.10.1	SK 50 - 1 / 10 - 100 ER 16	90,00
503.02.13.1	SK 50 - 2 / 13 - 100 ER 20	90,00
503.02.16.1	SK 50 - 2 / 16 - 100 ER 25	90,00
503.02.20.1	SK 50 - 2 / 20 - 100 ER 32	105,00
503.02.26.1	SK 50 - 3 / 26 - 100 ER 40	109,00
503.02.10.2	SK 50 - 1 / 10 - 160 ER 16	122,00
503.02.13.2	SK 50 - 2 / 13 - 160 ER 20	122,00
503.02.16.2	SK 50 - 2 / 16 - 160 ER 25	122,00
503.02.20.2	SK 50 - 2 / 20 - 160 ER 32	122,00
503.02.26.2	SK 50 - 3 / 26 - 160 ER 40	125,00
503.02.10.3	SK 50 - 1 / 10 - 200 ER 16	165,00
503.02.13.3	SK 50 - 2 / 13 - 200 ER 20	165,00
503.02.16.3	SK 50 - 2 / 16 - 200 ER 25	165,00
503.02.20.3	SK 50 - 2 / 20 - 200 ER 32	173,00
503.02.26.3	SK 50 - 3 / 26 - 200 ER 40	184,00



**Spannfutter für Spannzangen  
DIN 6499 (ISO 15488) System ER**  
Collet chucks for collets DIN 6499  
(ISO 15488) ER-system  
Mandrins à pinces pour pinces  
DIN 6499 (ISO 15488) système ER

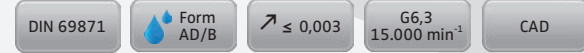

Bestell-Nr. Order no. / Réf.	Abmessung Size / Dimension	Euro
302.02.07*	SK 30 - 1 / 7 - 70 ER 11	87,00
302.02.07.1*	SK 30 - 1 / 7 - 100 ER 11	104,00
302.02.07.10*	SK 30 - 1 / 10 - 70 ER 16	87,00
302.02.07.10.1*	SK 30 - 1 / 10 - 100 ER 16	104,00
403.02.07	SK 40 - 1 / 7 - 55 ER 11	87,00
403.02.07.1	SK 40 - 1 / 7 - 100 ER 11	104,00
403.02.07.2	SK 40 - 1 / 7 - 160 ER 11	120,00
403.02.07.10	SK 40 - 1 / 10 - 55 ER 16	87,00
403.02.07.10.1	SK 40 - 1 / 10 - 100 ER 16	104,00
403.02.07.10.2	SK 40 - 1 / 10 - 160 ER 16	120,00
503.02.07.10.1	SK 50 - 1 / 10 - 100 ER 16	139,00
503.02.07.10.2	SK 50 - 1 / 10 - 160 ER 16	169,00

Mit Minimutter | With mini nut | Avec écrous-mini

\* Form AD | \* Form AD | \* Forme AD



### Gewuchtete Ausführung

Balanced type  
Type équilibré

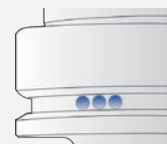

Bestell-Nr. Order no. / Référence	Abmessung Size / Dimension	Euro
--------------------------------------	-------------------------------	------

### Wuchten auf G 2,5 von vorgewuchteten Kemmler-Werkzeugen

Balancing at G 2.5 of pre-balanced Kemmler-tools  
Équilibrage sur G 2,5 d'outils Kemmler pré-équilibrés

W25	<b>Ohne Wuchtprotokoll</b> Without balancing report Sans protocole d'équilibrage	15,00
W25.2	<b>Mit Wuchtprotokoll</b> With balancing report Avec protocole d'équilibrage	19,00

### Wuchten von nicht vorgewuchteten Werkzeugen

Balancing of unbalanced tools  
Équilibrage d'outils non-équilibrés

W25.1	<b>Ohne Wuchtprotokoll</b> Without balancing report Sans protocole d'équilibrage	28,00
-------	----------------------------------------------------------------------------------------	-------

Внимание! Данный прайс-лист для европейского рынка.  
Цены в РФ значительно отличаются от цен, указанных в данном документе!  
Для получения актуальной стоимости, обращайтесь по контактам, указанным ниже.



## Werkzeugaufnahmen DIN 69871

Toolholders DIN 69871

Porte-outils DIN 69871



### Spannfutter für Spannzangen System KPS

Collet chucks for collets KPS-system  
Mandrins à pinces pour pinces système KPS

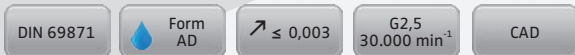

Bestell-Nr. Order no. / Réf.	Abmessung Size / Dimension		Euro
302.03.10	SK 30 - 1 / 10 - 60	KPS 10	104,00
302.03.16	SK 30 - 4 / 16 - 60	KPS 16	120,00
302.03.10.1	SK 30 - 1 / 10 - 90	KPS 10	109,00
302.03.16.1	SK 30 - 4 / 16 - 90	KPS 16	129,00
402.03.10	SK 40 - 1 / 10 - 60	KPS 10	114,00
402.03.16	SK 40 - 4 / 16 - 60	KPS 16	116,00
402.03.10.1	SK 40 - 1 / 10 - 90	KPS 10	122,00
402.03.16.1	SK 40 - 4 / 16 - 90	KPS 16	124,00
402.03.10.2	SK 40 - 1 / 10 - 120	KPS 10	131,00
402.03.16.2	SK 40 - 4 / 16 - 120	KPS 16	133,00
502.03.10	SK 50 - 1 / 10 - 105	KPS 10	213,00
502.03.16	SK 50 - 4 / 16 - 105	KPS 16	217,00
502.03.10.1	SK 50 - 1 / 10 - 135	KPS 10	228,00
502.03.16.1	SK 50 - 4 / 16 - 135	KPS 16	237,00
502.03.10.2	SK 50 - 1 / 10 - 165	KPS 10	248,00
502.03.16.2	SK 50 - 4 / 16 - 165	KPS 16	257,00



### Hochleistungs-Kraftspannfutter System HKS

High Performance Milling Chuck  
HKS-system  
Mandrin de serrage à haute performance système HKS

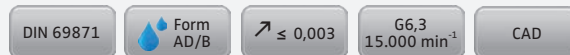

Bestell-Nr. Order no. / Référence	Abmessung Size / Dimension	Euro
403.64.20	SK 40 - 20 - 90	205,00
403.64.32	SK 40 - 32 - 105	216,00
503.64.20	SK 50 - 20 - 90	263,00
503.64.32	SK 50 - 32 - 90	273,00



Внимание! Данный прайс-лист для европейского рынка.

Цены в РФ значительно отличаются от цен, указанных в данном документе!

Для получения актуальной стоимости, обращайтесь по контактам, указанным ниже.

kemmler@kemmler.su  
www.kemmler.su



## Werkzeugaufnahmen DIN 69871

Toolholders DIN 69871

Porte-outils DIN 69871



### Spannfutter für Spannzangen DIN 6499 (ISO 15488) System ER ohne Mitnehmernuten

Collet chucks for collets DIN 6499  
(ISO 15488) ER-system  
without drive slots

Mandrins à pinces pour pinces DIN  
6499 (ISO 15488) système ER  
sans rainures d'entraînement

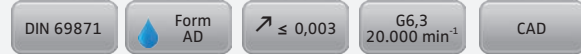

Bestell-Nr. Order no. / Réf.	Abmessung Size / Dimension	Euro
302.62.16	SK 30 - 2 / 16 - 50 ER 25	136,00
302.62.20	SK 30 - 2 / 20 - 50 ER 32	137,00
302.62.20.1	SK 30 - 2 / 20 - 57 ER 32	137,00
302.62.20.2	SK 30 - 2 / 20 - 63 ER 32	146,00
302.62.26	SK 30 - 3 / 26 - 60 ER 40	149,00
402.62.16	SK 40 - 2 / 16 - 50 ER 25	136,00
402.62.20	SK 40 - 2 / 20 - 50 ER 32	137,00
402.62.26	SK 40 - 3 / 26 - 63 ER 40	151,00



### Spannfutter DIN 6391 für Spannzangen DIN 6388 (ISO 10897) System OZ ohne Mitnehmernuten

Collet chucks DIN 6391 for collets  
DIN 6388 (ISO 10897) OZ-system  
without drive slots

Mandrins à pinces DIN 6391 pour pinces  
DIN 6388 (ISO 10897) système OZ  
sans rainures d'entraînement

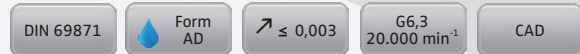

Bestell-Nr. Order no. / Réf.	Abmessung Size / Dimension	Euro
302.61.25	SK 30 - 2 / 25 - 71 OZ 25	170,00
402.61.25	SK 40 - 2 / 25 - 63 OZ 25	171,00



### Gewuchtete Ausführung

Balanced type  
Type équilibré



Bestell-Nr. Order no. / Référence	Abmessung Size / Dimension	Euro
--------------------------------------	-------------------------------	------

#### Wuchten auf G 2,5 von vorgewuchteten Kemmler-Werkzeugen

Balancing at G 2.5 of pre-balanced Kemmler-tools  
Équilibrage sur G 2,5 d'outils Kemmler pré-équilibrés

W25	<b>Ohne Wuchtprotokoll</b> Without balancing report Sans protocole d'équilibrage	15,00
W25.2	<b>Mit Wuchtprotokoll</b> With balancing report Avec protocole 'équilibrage	19,00

#### Wuchten von nicht vorgewuchteten Werkzeugen

Balancing of unbalanced tools  
Équilibrage d'outils non-équilibrés

W25.1	<b>Ohne Wuchtprotokoll</b> Without balancing report Sans protocole d'équilibrage	28,00
-------	----------------------------------------------------------------------------------------	-------

Внимание! Данный прайс-лист для европейского рынка.  
Цены в РФ значительно отличаются от цен, указанных в данном документе!  
Для получения актуальной стоимости, обращайтесь по контактам, указанным ниже.



## Werkzeugaufnahmen DIN 69871

Toolholders DIN 69871

Porte-outils DIN 69871



### Fräseraufnahmen DIN 6359 für Zylinderschäfte DIN 1835-B

End mill holders DIN 6359  
for end mills DIN 1835-B

Porte-fraises DIN 6359 pour queues  
cylindriques DIN 1835-B

DIN 69871



↗ ≤ 0,003

G6,3  
15.000 min<sup>-1</sup>

CAD

Bestell-Nr. Order no. / Référence	Abmessung Size / Dimension	Euro
302.04.06*	SK 30 - 06 - 50	39,00
302.04.08*	SK 30 - 08 - 50	36,00
302.04.10*	SK 30 - 10 - 50	36,00
302.04.12*	SK 30 - 12 - 50	36,00
302.04.14*	SK 30 - 14 - 63	36,00
302.04.16*	SK 30 - 16 - 63	36,00
302.04.18*	SK 30 - 18 - 63	36,00
302.04.20*	SK 30 - 20 - 70	36,00
403.04.16.0	SK 40 - 16 - 35	44,00
403.04.20.0	SK 40 - 20 - 35	44,00
403.04.25.0	SK 40 - 25 - 35	50,00
403.04.32.0	SK 40 - 32 - 65	53,00
403.04.06	SK 40 - 06 - 50	39,00
403.04.08	SK 40 - 08 - 50	36,00
403.04.10	SK 40 - 10 - 50	36,00
403.04.12	SK 40 - 12 - 50	36,00
403.04.14	SK 40 - 14 - 50	36,00
403.04.16	SK 40 - 16 - 63	36,00
403.04.18	SK 40 - 18 - 63	36,00
403.04.20	SK 40 - 20 - 63	36,00
403.04.25	SK 40 - 25 - 100	44,00
403.04.32	SK 40 - 32 - 100	46,00
403.04.40	SK 40 - 40 - 120	56,00
403.04.06.1	SK 40 - 06 - 100	47,00
403.04.08.1	SK 40 - 08 - 100	44,00
403.04.10.1	SK 40 - 10 - 100	44,00
403.04.12.1	SK 40 - 12 - 100	44,00
403.04.14.1	SK 40 - 14 - 100	44,00
403.04.16.1	SK 40 - 16 - 100	44,00
403.04.18.1	SK 40 - 18 - 100	44,00
403.04.20.1	SK 40 - 20 - 100	44,00
403.04.06.2	SK 40 - 06 - 160	77,00
403.04.08.2	SK 40 - 08 - 160	73,00
403.04.10.2	SK 40 - 10 - 160	73,00
403.04.12.2	SK 40 - 12 - 160	73,00
403.04.14.2	SK 40 - 14 - 160	73,00
403.04.16.2	SK 40 - 16 - 160	73,00
403.04.18.2	SK 40 - 18 - 160	73,00
403.04.20.2	SK 40 - 20 - 160	73,00
403.04.25.2	SK 40 - 25 - 160	80,00
403.04.32.2	SK 40 - 32 - 160	86,00
403.04.40.2	SK 40 - 40 - 160	101,00

\* Form AD | \* Form AD | \* Forme AD



### Fräseraufnahmen DIN 6359 für Zylinderschäfte DIN 1835-B

End mill holders DIN 6359  
for end mills DIN 1835-B

Porte-fraises DIN 6359 pour queues  
cylindriques DIN 1835-B

DIN 69871



↗ ≤ 0,003

G6,3  
15.000 min<sup>-1</sup>

CAD

Bestell-Nr. Order no. / Référence	Abmessung Size / Dimension	Euro
503.04.06	SK 50 - 06 - 63	55,00
503.04.08	SK 50 - 08 - 63	53,00
503.04.10	SK 50 - 10 - 63	53,00
503.04.12	SK 50 - 12 - 63	53,00
503.04.14	SK 50 - 14 - 63	53,00
503.04.16	SK 50 - 16 - 63	53,00
503.04.18	SK 50 - 18 - 63	53,00
503.04.20	SK 50 - 20 - 63	53,00
503.04.25	SK 50 - 25 - 80	59,00
503.04.32	SK 50 - 32 - 100	63,00
503.04.40	SK 50 - 40 - 100	69,00
503.04.06.1	SK 50 - 06 - 100	66,00
503.04.08.1	SK 50 - 08 - 100	63,00
503.04.10.1	SK 50 - 10 - 100	63,00
503.04.12.1	SK 50 - 12 - 100	63,00
503.04.14.1	SK 50 - 14 - 100	63,00
503.04.16.1	SK 50 - 16 - 100	63,00
503.04.18.1	SK 50 - 18 - 100	63,00
503.04.20.1	SK 50 - 20 - 100	63,00
503.04.25.1	SK 50 - 25 - 120	77,00
503.04.06.2	SK 50 - 06 - 160	99,00
503.04.08.2	SK 50 - 08 - 160	96,00
503.04.10.2	SK 50 - 10 - 160	96,00
503.04.12.2	SK 50 - 12 - 160	96,00
503.04.14.2	SK 50 - 14 - 160	96,00
503.04.16.2	SK 50 - 16 - 160	96,00
503.04.18.2	SK 50 - 18 - 160	96,00
503.04.20.2	SK 50 - 20 - 160	96,00
503.04.25.2	SK 50 - 25 - 160	99,00
503.04.32.2	SK 50 - 32 - 160	102,00
503.04.40.2	SK 50 - 40 - 160	108,00
503.04.06.3	SK 50 - 06 - 200	199,00
503.04.08.3	SK 50 - 08 - 200	196,00
503.04.10.3	SK 50 - 10 - 200	196,00
503.04.12.3	SK 50 - 12 - 200	196,00
503.04.14.3	SK 50 - 14 - 200	196,00
503.04.16.3	SK 50 - 16 - 200	196,00
503.04.18.3	SK 50 - 18 - 200	196,00
503.04.20.3	SK 50 - 20 - 200	196,00
503.04.25.3	SK 50 - 25 - 200	205,00
503.04.32.3	SK 50 - 32 - 200	210,00
503.04.40.3	SK 50 - 40 - 200	215,00

Внимание! Данный прайс-лист для европейского рынка.

Цены в РФ значительно отличаются от цен, указанных в данном документе!

Для получения актуальной стоимости, обращайтесь по контактам, указанным ниже.

kemmler@kemmler.su  
www.kemmler.su



## Werkzeugaufnahmen DIN 69871

Toolholders DIN 69871

Porte-outils DIN 69871

### Fräseraufnahmen DIN 6359 mit Kühlkanälen für Zylinderschäfte DIN 1835-B

End mill holders DIN 6359

with coolant channels

for end mills DIN 1835-B

Porte-fraises DIN 6359

avec canaux d'arrosage pour

queues cylindriques DIN 1835-B



DIN 69871



$\nearrow \leq 0,003$

G6,3  
15.000 min<sup>-1</sup>

CAD

Bestell-Nr. Order no. / Référence	Abmessung Size / Dimension	Euro
403.04.06.K	SK 40 - 06 - 50	51,00
403.04.08.K	SK 40 - 08 - 50	49,00
403.04.10.K	SK 40 - 10 - 50	49,00
403.04.12.K	SK 40 - 12 - 50	49,00
403.04.14.K	SK 40 - 14 - 50	49,00
403.04.16.K	SK 40 - 16 - 63	49,00
403.04.18.K	SK 40 - 18 - 63	49,00
403.04.20.K	SK 40 - 20 - 63	49,00
403.04.25.K	SK 40 - 25 - 100	55,00
403.04.32.K	SK 40 - 32 - 100	59,00
403.04.40.K	SK 40 - 40 - 120	70,00
403.04.06.1.K	SK 40 - 06 - 100	61,00
403.04.08.1.K	SK 40 - 08 - 100	59,00
403.04.10.1.K	SK 40 - 10 - 100	59,00
403.04.12.1.K	SK 40 - 12 - 100	59,00
403.04.14.1.K	SK 40 - 14 - 100	59,00
403.04.16.1.K	SK 40 - 16 - 100	59,00
403.04.18.1.K	SK 40 - 18 - 100	59,00
403.04.20.1.K	SK 40 - 20 - 100	59,00
503.04.06.K	SK 50 - 06 - 63	77,00
503.04.08.K	SK 50 - 08 - 63	74,00
503.04.10.K	SK 50 - 10 - 63	74,00
503.04.12.K	SK 50 - 12 - 63	74,00
503.04.14.K	SK 50 - 14 - 63	74,00
503.04.16.K	SK 50 - 16 - 63	74,00
503.04.18.K	SK 50 - 18 - 63	74,00
503.04.20.K	SK 50 - 20 - 63	74,00
503.04.25.K	SK 50 - 25 - 80	80,00
503.04.32.K	SK 50 - 32 - 100	81,00
503.04.40.K	SK 50 - 40 - 100	86,00
503.04.06.1.K	SK 50 - 06 - 100	94,00
503.04.08.1.K	SK 50 - 08 - 100	94,00
503.04.10.1.K	SK 50 - 10 - 100	94,00
503.04.12.1.K	SK 50 - 12 - 100	94,00
503.04.14.1.K	SK 50 - 14 - 100	94,00
503.04.16.1.K	SK 50 - 16 - 100	94,00
503.04.18.1.K	SK 50 - 18 - 100	94,00
503.04.20.1.K	SK 50 - 20 - 100	94,00



### Fräseraufnahmen DIN 6359 für Zylinderschäfte DIN 1835-B

End mill holders DIN 6359

for end mills DIN 1835-B

Porte-fraises DIN 6359 pour queues

cylindriques DIN 1835-B

DIN 69871



$\nearrow \leq 0,003$

G6,3  
15.000 min<sup>-1</sup>

CAD

Bestell-Nr. Order no. / Référence	Abmessung Size / Dimension	Euro
402.04.06	SK 40 - 06 - 50	34,00
402.04.08	SK 40 - 08 - 50	32,00
402.04.10	SK 40 - 10 - 50	32,00
402.04.12	SK 40 - 12 - 50	32,00
402.04.14	SK 40 - 14 - 50	32,00
402.04.16	SK 40 - 16 - 63	32,00
402.04.18	SK 40 - 18 - 63	32,00
402.04.20	SK 40 - 20 - 63	32,00
402.04.25	SK 40 - 25 - 100	37,00
402.04.32	SK 40 - 32 - 100	39,00
402.04.06.1	SK 40 - 06 - 100	45,00
402.04.08.1	SK 40 - 08 - 100	42,00
402.04.10.1	SK 40 - 10 - 100	42,00
402.04.12.1	SK 40 - 12 - 100	42,00
402.04.14.1	SK 40 - 14 - 100	42,00
402.04.16.1	SK 40 - 16 - 100	42,00
402.04.18.1	SK 40 - 18 - 100	42,00
402.04.20.1	SK 40 - 20 - 100	42,00



110



1

Внимание! Данный прайс-лист для европейского рынка.  
Цены в РФ значительно отличаются от цен, указанных в данном документе!  
Для получения актуальной стоимости, обращайтесь по контактам, указанным ниже.



## Werkzeugaufnahmen DIN 69871

Toolholders DIN 69871

Porte-outils DIN 69871



### Fräseraufnahmen DIN 6359 für Zylinderschäfte DIN 1835-E Whistle Notch

End mill holders DIN 6359 for end mills DIN 1835-E Whistle Notch  
Porte-fraises DIN 6359 pour queues cylindriques DIN 1835-E Whistle Notch

DIN 69871



CAD

Bestell-Nr. Order no. / Référence	Abmessung Size / Dimension	Euro
403.05.06	SK 40 - 06 - 50	45,00
403.05.08	SK 40 - 08 - 50	41,00
403.05.10	SK 40 - 10 - 50	41,00
403.05.12	SK 40 - 12 - 50	41,00
403.05.14	SK 40 - 14 - 50	41,00
403.05.16	SK 40 - 16 - 63	41,00
403.05.18	SK 40 - 18 - 63	41,00
403.05.20	SK 40 - 20 - 63	41,00
403.05.25	SK 40 - 25 - 100	49,00
403.05.32	SK 40 - 32 - 100	54,00
403.05.40	SK 40 - 40 - 120	63,00
503.05.06	SK 50 - 06 - 63	62,00
503.05.08	SK 50 - 08 - 63	60,00
503.05.10	SK 50 - 10 - 63	60,00
503.05.12	SK 50 - 12 - 63	60,00
503.05.14	SK 50 - 14 - 63	60,00
503.05.16	SK 50 - 16 - 63	60,00
503.05.18	SK 50 - 18 - 63	60,00
503.05.20	SK 50 - 20 - 63	60,00
503.05.25	SK 50 - 25 - 80	67,00
503.05.32	SK 50 - 32 - 100	72,00
503.05.40	SK 50 - 40 - 100	77,00



### Zwischenhülsen für MK mit Austreibblappen DIN 6383

Adaptor sleeves for MT with tang DIN 6383  
Douilles de réduction pour CM à tenon DIN 6383

DIN 69871



CAD

Bestell-Nr. Order no. / Référence	Abmessung Size / Dimension	Euro
302.07.01	SK 30 - 1 - 50	36,00
302.07.02	SK 30 - 2 - 65	36,00
302.07.03	SK 30 - 3 - 80	36,00
402.07.01	SK 40 - 1 - 50	34,00
402.07.02	SK 40 - 2 - 50	34,00
402.07.03	SK 40 - 3 - 70	34,00
402.07.04	SK 40 - 4 - 95	37,00



### Zwischenhülsen für MK mit Anzugsgewinde DIN 6364

Adaptor sleeves for MT with drawbar thread DIN 6364  
Douilles de réduction pour CM avec filetage DIN 6364

DIN 69871



CAD

Bestell-Nr. Order no. / Référence	Abmessung Size / Dimension	Euro
402.08.01	SK 40 - 1 - 50	59,00
402.08.02	SK 40 - 2 - 50	59,00
402.08.03	SK 40 - 3 - 70	59,00
402.08.04	SK 40 - 4 - 95	63,00
402.08.04A*	SK 40 - 4 - 110	70,00
502.08.01	SK 50 - 1 - 45	77,00
502.08.02	SK 50 - 2 - 60	77,00
502.08.03	SK 50 - 3 - 65	77,00
502.08.04	SK 50 - 4 - 70	83,00
502.08.04A*	SK 50 - 4 - 85	90,00
502.08.05	SK 50 - 5 - 100	86,00
502.08.05A*	SK 50 - 5 - 118	97,00

\* Mit Mitnahmeausfräsung nach DIN 2201

\* With drive flats according to DIN 2201

\* Avec des fraises d'entraînement suivant DIN 2201



### Zwischenhülsen für MK mit Austreibblappen DIN 6383

Adaptor sleeves for MT with tang DIN 6383  
Douilles de réduction pour CM à tenon DIN 6383

DIN 69871



CAD

Bestell-Nr. Order no. / Référence	Abmessung Size / Dimension	Euro
403.07.01	SK 40 - 1 - 50	36,00
403.07.02	SK 40 - 2 - 50	36,00
403.07.03	SK 40 - 3 - 70	36,00
403.07.04	SK 40 - 4 - 95	40,00
402.07.02.1*	SK 40 - 2 - 117	62,00
402.07.03.1*	SK 40 - 3 - 133	62,00
402.07.04.1*	SK 40 - 4 - 156	70,00
503.07.01	SK 50 - 1 - 45	51,00
503.07.02	SK 50 - 2 - 60	51,00
503.07.03	SK 50 - 3 - 65	51,00
503.07.04	SK 50 - 4 - 95	51,00
503.07.05	SK 50 - 5 - 105	56,00
502.07.02.1*	SK 50 - 2 - 117	118,00
502.07.03.1*	SK 50 - 3 - 137	118,00
502.07.04.1*	SK 50 - 4 - 167	130,00
502.07.05.1*	SK 50 - 5 - 197	138,00

\* Form AD | \* Form AD | \* Forme AD

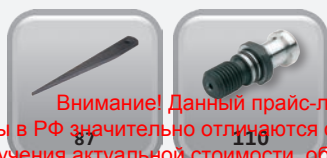

Внимание! Данный прайс-лист для европейского рынка.

Цены в РФ значительно отличаются от цен, указанных в данном документе!

Для получения актуальной стоимости, обращайтесь по контактам, указанным ниже.

kemmler@kemmler.su

www.kemmler.su

## Werkzeugaufnahmen DIN 69871

Toolholders DIN 69871

Porte-outils DIN 69871

### Quernut-Aufsteckfräserdorne

DIN 6357 mit vergrößerter  
Anlagefläche und Kühlkanal-  
bohrungen an der Stirnseite  
Shell mill holders DIN 6357 with  
enlarged contact face and coolant  
exit bores on the end face

Porte-fraises à trou lisse DIN 6357  
avec face de contact élargie  
et conduits pour l'arrosage frontal



DIN 69871



$\nearrow \leq 0,005$

G6,3  
15.000 min<sup>-1</sup>

CAD

Bestell-Nr. Order no. / Référence	Abmessung Size / Dimension	Euro
402.11.16	SK 40 - 16 - 35	48,00
402.11.22	SK 40 - 22 - 35	48,00
402.11.27	SK 40 - 27 - 40	49,00
402.11.32	SK 40 - 32 - 50	52,00
402.11.40	SK 40 - 40 - 50	64,00



125



125



110



### Zwischenhülsen für SK-Aufnahmen

Adaptor sleeves for ISO-toolholders  
Douilles de réduction  
pour porte-outils ISO/SA

DIN 69871



$\nearrow \leq 0,005$

G6,3  
15.000 min<sup>-1</sup>

CAD

Bestell-Nr. Order no. / Référence	Abmessung Size / Dimension	Euro
402.09.30	SK 40 - SK 30 - 50	89,00
402.09.40	SK 40 - SK 40 - 100	89,00
502.09.40	SK 50 - SK 40 - 70	112,00
502.09.50	SK 50 - SK 50 - 120	129,00

### Quernut-Aufsteckfräserdorne

DIN 6357 mit vergrößerter  
Anlagefläche und Kühlkanal-  
bohrungen an der Stirnseite  
Shell mill holders DIN 6357 with  
enlarged contact face and coolant  
exit bores on the end face

Porte-fraises à trou lisse DIN 6357  
avec face de contact élargie  
et conduits pour l'arrosage frontal



DIN 69871



$\nearrow \leq 0,005$

G6,3  
15.000 min<sup>-1</sup>

CAD

Bestell-Nr. Order no. / Référence	Abmessung Size / Dimension	Euro
302.11.16*	SK 30 - 16 - 40	50,00
302.11.22*	SK 30 - 22 - 40	50,00
302.11.27*	SK 30 - 27 - 40	51,00
302.11.32*	SK 30 - 32 - 50	54,00

403.11.16	SK 40 - 16 - 35	50,00
403.11.22	SK 40 - 22 - 35	50,00
403.11.27	SK 40 - 27 - 40	51,00
403.11.32	SK 40 - 32 - 50	54,00
403.11.40	SK 40 - 40 - 50	66,00
403.11.16.1	SK 40 - 16 - 100	61,00
403.11.22.1	SK 40 - 22 - 100	61,00
403.11.27.1	SK 40 - 27 - 100	62,00
403.11.32.1	SK 40 - 32 - 100	67,00
403.11.40.1	SK 40 - 40 - 100	79,00
403.11.16.2	SK 40 - 16 - 160	98,00
403.11.22.2	SK 40 - 22 - 160	99,00
403.11.27.2	SK 40 - 27 - 160	101,00
403.11.32.2	SK 40 - 32 - 160	107,00
403.11.40.2	SK 40 - 40 - 160	119,00

503.11.16	SK 50 - 16 - 45	66,00
503.11.22	SK 50 - 22 - 35	66,00
503.11.27	SK 50 - 27 - 40	66,00
503.11.32	SK 50 - 32 - 50	70,00
503.11.40	SK 50 - 40 - 50	80,00
503.11.60	SK 50 - 60 - 70	122,00
503.11.16.1	SK 50 - 16 - 100	79,00
503.11.22.1	SK 50 - 22 - 100	79,00
503.11.27.1	SK 50 - 27 - 100	79,00
503.11.32.1	SK 50 - 32 - 100	84,00
503.11.40.1	SK 50 - 40 - 100	97,00
503.11.16.2	SK 50 - 16 - 160	125,00
503.11.22.2	SK 50 - 22 - 160	125,00
503.11.27.2	SK 50 - 27 - 160	126,00
503.11.32.2	SK 50 - 32 - 160	130,00
503.11.40.2	SK 50 - 40 - 160	141,00
503.11.16.3	SK 50 - 16 - 200	180,00
503.11.22.3	SK 50 - 22 - 200	180,00
503.11.27.3	SK 50 - 27 - 200	185,00
503.11.32.3	SK 50 - 32 - 200	190,00
503.11.40.3	SK 50 - 40 - 200	205,00

\* Form AD | \* Form AD | \* Forme AD

Внимание! Данный прайс-лист для европейского рынка.  
Цены в РФ значительно отличаются от цен, указанных в данном документе!  
Для получения актуальной стоимости, обращайтесь по контактам, указанным ниже.



## Werkzeugaufnahmen DIN 69871

Toolholders DIN 69871

Porte-outils DIN 69871



### Kombi-Aufsteckfräserdorne DIN 6358

Combi shell mill holders DIN 6358  
Porte-fraises à double usage  
DIN 6358

DIN 69871



CAD

Bestell-Nr. Order no. / Référence	Abmessung Size / Dimension	Euro
302.10.16*	SK 30 - 16 - 50	46,00
302.10.22*	SK 30 - 22 - 50	47,00
302.10.27*	SK 30 - 27 - 55	47,00
302.10.32*	SK 30 - 32 - 60	51,00

403.10.16	SK 40 - 16 - 55	46,00
403.10.22	SK 40 - 22 - 55	47,00
403.10.27	SK 40 - 27 - 55	47,00
403.10.32	SK 40 - 32 - 60	51,00
403.10.40	SK 40 - 40 - 60	58,00
403.10.16.1	SK 40 - 16 - 100	56,00
403.10.22.1	SK 40 - 22 - 100	58,00
403.10.27.1	SK 40 - 27 - 100	59,00
403.10.32.1	SK 40 - 32 - 100	61,00
403.10.40.1	SK 40 - 40 - 100	69,00
403.10.16.2	SK 40 - 16 - 160	92,00
403.10.22.2	SK 40 - 22 - 160	96,00
403.10.27.2	SK 40 - 27 - 160	100,00
403.10.32.2	SK 40 - 32 - 160	103,00
403.10.40.2	SK 40 - 40 - 160	112,00

503.10.16	SK 50 - 16 - 55	62,00
503.10.22	SK 50 - 22 - 55	62,00
503.10.27	SK 50 - 27 - 55	63,00
503.10.32	SK 50 - 32 - 55	66,00
503.10.40	SK 50 - 40 - 55	72,00
503.10.16.1	SK 50 - 16 - 100	73,00
503.10.22.1	SK 50 - 22 - 100	73,00
503.10.27.1	SK 50 - 27 - 100	74,00
503.10.32.1	SK 50 - 32 - 100	76,00
503.10.40.1	SK 50 - 40 - 100	82,00
503.10.16.2	SK 50 - 16 - 160	134,00
503.10.22.2	SK 50 - 22 - 160	138,00
503.10.27.2	SK 50 - 27 - 160	145,00
503.10.32.2	SK 50 - 32 - 160	150,00
503.10.40.2	SK 50 - 40 - 160	161,00

\* Form AD | \* Form AD | \* Forme AD



### Bohrstangenrohlinge

Boring bar blanks  
Barres d'alésage

DIN 69871



CAD

Bestell-Nr. Order no. / Référence	Abmessung Size / Dimension	Euro
302.17.40	SK 30 - 40,5 - 160	108,00
402.17.63	SK 40 - 63 - 250	110,00
502.17.97	SK 50 - 97 - 315	179,00

Внимание! Данный прайс-лист для европейского рынка.

Цены в РФ значительно отличаются от цен, указанных в данном документе!

Для получения актуальной стоимости, обращайтесь по контактам, указанным ниже.

kemmler@kemmler.su  
www.kemmler.su



## Werkzeugaufnahmen DIN 69871

Toolholders DIN 69871

Porte-outils DIN 69871



**Fräsaufnahme für Einschraubfräser**  
Milling arbors for screw-in cutters  
Porte-fraises pour fraises à queue filetée

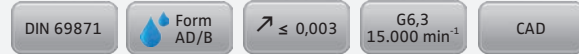

Bestell-Nr. Order no. / Référence	Abmessung Size / Dimension	Euro
403.06.06	SK 40 - M6 - 44	88,00
403.06.06.1	SK 40 - M6 - 69	100,00
403.06.06.2	SK 40 - M6 - 94	110,00
403.06.08	SK 40 - M8 - 44	88,00
403.06.08.1	SK 40 - M8 - 69	100,00
403.06.08.2	SK 40 - M8 - 94	110,00
403.06.08.3	SK 40 - M8 - 119	123,00
403.06.10.0	SK 40 - M10 - 24	83,00
403.06.10	SK 40 - M10 - 44	88,00
403.06.10.1	SK 40 - M10 - 69	95,00
403.06.10.2	SK 40 - M10 - 94	110,00
403.06.10.3	SK 40 - M10 - 119	126,00
403.06.10.5	SK 40 - M10 - 169	152,00
403.06.12.0	SK 40 - M12 - 24	83,00
403.06.12	SK 40 - M12 - 44	88,00
403.06.12.1	SK 40 - M12 - 69	95,00
403.06.12.2	SK 40 - M12 - 94	110,00
403.06.12.3	SK 40 - M12 - 119	126,00
403.06.12.5	SK 40 - M12 - 169	152,00
403.06.16.0	SK 40 - M16 - 24	84,00
403.06.16	SK 40 - M16 - 44	88,00
403.06.16.1	SK 40 - M16 - 69	100,00
403.06.16.2	SK 40 - M16 - 94	110,00
403.06.16.3	SK 40 - M16 - 119	126,00
403.06.16.5	SK 40 - M16 - 169	152,00
503.06.08.1	SK 50 - M8 - 69	119,00
503.06.08.3	SK 50 - M8 - 119	147,00
503.06.08.5	SK 50 - M8 - 169	172,00
503.06.10.1	SK 50 - M10 - 69	119,00
503.06.10.3	SK 50 - M10 - 119	147,00
503.06.10.5	SK 50 - M10 - 169	172,00
503.06.12.1	SK 50 - M12 - 69	119,00
503.06.12.3	SK 50 - M12 - 119	147,00
503.06.12.5	SK 50 - M12 - 169	172,00
503.06.16.1	SK 50 - M16 - 69	119,00
503.06.16.3	SK 50 - M16 - 119	147,00
503.06.16.5	SK 50 - M16 - 169	172,00



**Bohrerhalter für Wendeplattenbohrer Form E1**  
Boring holders for drills with indexable inserts form E1  
Portes forets pour forets à plaquettes réversibles forme E1

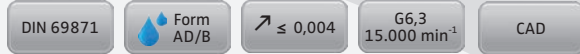

Bestell-Nr. Order no. / Référence	Abmessung Size / Dimension	Euro
403.51.20	SK 40 - 20 - 65	59,00
403.51.25	SK 40 - 25 - 70	59,00
403.51.32	SK 40 - 32 - 75	59,00
503.51.20	SK 50 - 20 - 70	87,00
503.51.25	SK 50 - 25 - 70	87,00
503.51.32	SK 50 - 32 - 70	87,00
503.51.40	SK 50 - 40 - 80	87,00



### Gewuchtete Ausführung

Balanced type

Type équilibré



Bestell-Nr. Order no. / Référence	Abmessung Size / Dimension	Euro
--------------------------------------	-------------------------------	------

### Wuchten auf G 2,5 von vorgewuchteten Kemmler-Werkzeugen

Balancing at G 2.5 of pre-balanced Kemmler-tools

Équilibrage sur G 2,5 d'outils Kemmler pré-équilibrés

W25	<b>Ohne Wuchtprotokoll</b> Without balancing report Sans protocole d'équilibrage	15,00
-----	----------------------------------------------------------------------------------------	-------

W25.2	<b>Mit Wuchtprotokoll</b> With balancing report Avec protocole d'équilibrage	19,00
-------	------------------------------------------------------------------------------------	-------

### Wuchten von nicht vorgewuchteten Werkzeugen

Balancing of unbalanced tools

Équilibrage d'outils non-équilibrés

W25.1	<b>Ohne Wuchtprotokoll</b> Without balancing report Sans protocole d'équilibrage	28,00
-------	----------------------------------------------------------------------------------------	-------

Внимание! Данный прайс-лист для европейского рынка.  
Цены в РФ значительно отличаются от цен, указанных в данном документе!  
Для получения актуальной стоимости, обращайтесь по контактам, указанным ниже.



## Werkzeugaufnahmen DIN 69871

Toolholders DIN 69871

Porte-outils DIN 69871



**CNC-Bohrfutter  
für Rechts- und Linkslauf**  
CNC-Drill chucks for clockwise  
and counter clockwise rotation  
Mandrins de perçage CNC  
pour rotation gauche-droite

DIN 69871 Form AD  $\sqrt{\leq 0,03}$  G6,3 15.000 min<sup>-1</sup> CAD

Bestell-Nr. Order no. / Référence	Abmessung Size / Dimension	Euro
302.15.08	SK 30 - 0,5/ 8 - 70	328,00
302.15.13	SK 30 - 1,0 / 13 - 111	273,00
302.15.16	SK 30 - 2,5 / 16 - 116	294,00
402.15.08	SK 40 - 0,5/ 8 - 70	246,00
402.15.13	SK 40 - 1,0/ 13 - 90	190,00
402.15.16	SK 40 - 2,5 / 16 - 95	195,00
502.15.13	SK 50 - 1,0 / 13 - 90	257,00
502.15.16	SK 50 - 2,5 / 16 - 95	273,00



**Bohrfutteraufnahmen DIN 238**  
Drill chuck adaptors DIN 238  
Arbres pour mandrins de perçage  
DIN 238

DIN 69871 Form A  $\sqrt{\leq 0,005}$  G6,3 15.000 min<sup>-1</sup> CAD

Bestell-Nr. Order no. / Référence	Abmessung Size / Dimension	Euro
302.14.12	SK 30 - B12	39,00
302.14.16	SK 30 - B16	39,00
402.14.12	SK 40 - B12	39,00
402.14.16	SK 40 - B16	39,00
402.14.18	SK 40 - B18	39,00
502.14.12	SK 50 - B12	50,00
502.14.16	SK 50 - B16	50,00
502.14.18	SK 50 - B18	50,00



**CNC-Bohrfutter  
für Rechts- und Linkslauf**  
CNC-Drill chucks for clockwise  
and counter clockwise rotation  
Mandrins de perçage CNC  
pour rotation gauche-droite

DIN 69871 Form AD/B  $\sqrt{\leq 0,03}$  G6,3 15.000 min<sup>-1</sup> CAD

Bestell-Nr. Order no. / Référence	Abmessung Size / Dimension	Euro
403.15.08	SK 40 - 0,5/ 8 - 70	302,00
403.15.13	SK 40 - 1,0/ 13 - 90	257,00
403.15.16	SK 40 - 2,5 / 16 - 95	279,00
503.15.13	SK 50 - 1,0 / 13 - 90	302,00
503.15.16	SK 50 - 2,5 / 16 - 95	324,00

Внимание! Данный прайс-лист для европейского рынка.

Цены в РФ значительно отличаются от цен, указанных в данном документе!

Для получения актуальной стоимости, обращайтесь по контактам, указанным ниже.

kemmler@kemmler.su  
www.kemmler.su



## Werkzeugaufnahmen DIN 69871

Toolholders DIN 69871

Porte-outils DIN 69871



### Гewindeschneid-Schnellwechsel-futter mit Längenausgleich auf Druck und Zug

Quick change tapping chucks with length compensation on compression and expansion

Mandrins de taraudage à changement rapide avec compensation longitudinale à la compression et traction

DIN 69871

Form A

CAD

Bestell-Nr. Order no. / Référence	Abmessung Size / Dimension		Euro
302.16.12	SK 30 - M3 / M14	Gr. 1	179,00
302.16.20	SK 30 - M5 / M22	Gr. 2	191,00
402.16.12	SK 40 - M3 / M14	Gr. 1	179,00
402.16.20	SK 40 - M5 / M22	Gr. 2	191,00
402.16.36	SK 40 - M14 / M36	Gr. 3	290,00
502.16.12	SK 50 - M3 / M14	Gr. 1	223,00
502.16.20	SK 50 - M5 / M22	Gr. 2	235,00
502.16.36	SK 50 - M14 / M36	Gr. 3	334,00



### Гewindeschneidfutter für Synchronisation für Spannzangen DIN 6499 (ISO 15488) System ER

Tapping chucks for synchronisation for collets DIN 6499 (ISO 15488) ER-system

Mandrins de taraudage pour synchronisation pour pinces DIN 6499 (ISO 15488) système ER

DIN 69871

Form AD/B

G6,3  
15.000 min<sup>-1</sup>

CAD

Bestell-Nr. Order no. / Référence	Abmessung Size / Dimension	Euro
302.16.02.13 **	SK 30 - ER20 - 85	542,00
403.16.02.10	SK 40 - ER16 - 79	528,00
403.16.02.10.M*	SK 40 - ER16 - 79	528,00
403.16.02.13	SK 40 - ER20 - 80	542,00
403.16.02.16	SK 40 - ER25 - 84	542,00
403.16.02.20	SK 40 - ER32 - 95	542,00
403.16.02.26	SK 40 - ER40 - 120	576,00
503.16.02.10	SK 50 - ER16 - 79	576,00
503.16.02.10.M*	SK 50 - ER16 - 79	576,00
503.16.02.10.1.M*	SK 50 - ER16 - 90	615,00
503.16.02.13	SK 50 - ER20 - 80	576,00
503.16.02.16	SK 50 - ER25 - 84	576,00
503.16.02.20	SK 50 - ER32 - 95	624,00
503.16.02.26	SK 50 - ER40 - 105	691,00

\*Mit Minimutter | \*With mini nut | \*Avec écrous-mini

\*\* Form AD | \*\* Form AD | \*\* Forme AD

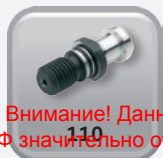

Внимание! Данный прайс-лист для европейского рынка.  
Цены в РФ значительно отличаются от цен, указанных в данном документе!  
Для получения актуальной стоимости, обращайтесь по контактам, указанным ниже.

kemmler@kemmler.su  
www.kemmler.su

### Гewindeschneid-Schnellwechsel-futter ohne Längenausgleich auf Druck und Zug

Quick-change tapping chucks without length compensation on compression and expansion

Mandrins de taraudage à changement rapide sans compensation longitudinale à la compression et traction

DIN 69871

Form AD

CAD

Bestell-Nr. Order no. / Référence	Abmessung Size / Dimension		Euro
302.16.12.1	SK 30 - M3 / M14	Gr. 1	135,00
302.16.20.1	SK 30 - M5 / M22	Gr. 2	145,00
402.16.12.1	SK 40 - M3 / M14	Gr. 1	135,00
402.16.20.1	SK 40 - M5 / M22	Gr. 2	145,00
402.16.36.1	SK 40 - M14 / M36	Gr. 3	223,00
502.16.12.1	SK 50 - M3 / M14	Gr. 1	179,00
502.16.20.1	SK 50 - M5 / M22	Gr. 2	191,00
502.16.36.1	SK 50 - M14 / M36	Gr. 3	246,00



### Гewuchtete Ausführung

Balanced type

Type équilibré



Bestell-Nr. Order no. / Référence	Abmessung Size / Dimension	Euro
W25	<b>Ohne Wuchtprotokoll</b> Without balancing report Sans protocole d'équilibrage	15,00
W25.2	<b>Mit Wuchtprotokoll</b> With balancing report Avec protocole d'équilibrage	19,00

### Wuchten von nicht vorgewuchteten Werkzeugen

Balancing of unbalanced tools

Equilibrage d'outils non-équilibrés

W25.1	<b>Ohne Wuchtprotokoll</b> Without balancing report Sans protocole d'équilibrage	28,00
-------	----------------------------------------------------------------------------------------	-------



## Werkzeugaufnahmen DIN 69871

Toolholders DIN 69871

Porte-outils DIN 69871



**Hydro-Dehnspannfutter**  
Hydraulic expansion chucks  
Mandrins expansibles hydrauliques

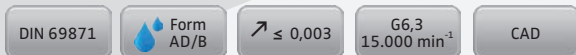

Bestell-Nr. Order no. / Référence	Abmessung Size / Dimension	Euro
302.H06 *	SK 30 - 06 - 60	539,00
302.H08 *	SK 30 - 08 - 64	539,00
302.H10 *	SK 30 - 10 - 72	539,00
302.H12 *	SK 30 - 12 - 72	539,00
302.H14 *	SK 30 - 14 - 72	539,00
302.H16 *	SK 30 - 16 - 90	539,00
302.H18 *	SK 30 - 18 - 90	539,00
302.H20 *	SK 30 - 20 - 90	539,00
403.H06	SK 40 - 06 - 68	329,00
403.H08	SK 40 - 08 - 68	329,00
403.H10	SK 40 - 10 - 72	329,00
403.H12	SK 40 - 12 - 77	329,00
403.H14	SK 40 - 14 - 77	329,00
403.H16	SK 40 - 16 - 80	329,00
403.H18	SK 40 - 18 - 80	329,00
403.H20	SK 40 - 20 - 82	329,00
403.H25	SK 40 - 25 - 117	329,00
403.H32	SK 40 - 32 - 117	329,00
403.H06.1	SK 40 - 06 - 110	538,00
403.H08.1	SK 40 - 08 - 110	538,00
403.H10.1	SK 40 - 10 - 110	538,00
403.H12.1	SK 40 - 12 - 110	538,00
403.H14.1	SK 40 - 14 - 110	538,00
403.H16.1	SK 40 - 16 - 110	538,00
403.H18.1	SK 40 - 18 - 110	538,00
403.H20.1	SK 40 - 20 - 110	538,00

\* Form AD | \* Form AD | \* Forme AD



**Hydro-Dehnspannfutter**  
Hydraulic expansion chucks  
Mandrins expansibles hydrauliques

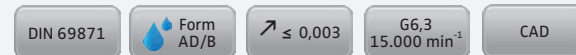

Bestell-Nr. Order no. / Référence	Abmessung Size / Dimension	Euro
503.H06	SK 50 - 06 - 68	460,00
503.H08	SK 50 - 08 - 68	460,00
503.H10	SK 50 - 10 - 72	460,00
503.H12	SK 50 - 12 - 77	460,00
503.H14	SK 50 - 14 - 77	460,00
503.H16	SK 50 - 16 - 80	460,00
503.H18	SK 50 - 18 - 80	460,00
503.H20	SK 50 - 20 - 82	460,00
503.H25	SK 50 - 25 - 87	460,00
503.H32	SK 50 - 32 - 91	460,00
503.H06.1	SK 50 - 06 - 110	679,00
503.H08.1	SK 50 - 08 - 110	679,00
503.H10.1	SK 50 - 10 - 110	679,00
503.H12.1	SK 50 - 12 - 110	679,00
503.H14.1	SK 50 - 14 - 110	679,00
503.H16.1	SK 50 - 16 - 110	679,00
503.H18.1	SK 50 - 18 - 110	679,00
503.H20.1	SK 50 - 20 - 110	679,00
503.H25.1	SK 50 - 25 - 110	679,00
503.H32.1	SK 50 - 32 - 110	679,00
503.H06.2	SK 50 - 06 - 150	1033,00
503.H08.2	SK 50 - 08 - 150	1033,00
503.H10.2	SK 50 - 10 - 150	1033,00
503.H12.2	SK 50 - 12 - 150	1033,00
503.H14.2	SK 50 - 14 - 150	1033,00
503.H16.2	SK 50 - 16 - 150	1033,00
503.H18.2	SK 50 - 18 - 150	1033,00
503.H20.2	SK 50 - 20 - 150	1033,00
503.H25.2	SK 50 - 25 - 150	1033,00
503.H32.2	SK 50 - 32 - 150	1033,00
503.H40.2	SK 50 - 40 - 150	1115,00

Внимание! Данный прайс-лист для европейского рынка.

Цены в РФ значительно отличаются от цен, указанных в данном документе!

Для получения актуальной стоимости, обращайтесь по контактам, указанным ниже.

kemmler@kemmler.su  
www.kemmler.su



## Werkzeugaufnahmen DIN 69871

Toolholders DIN 69871

Porte-outils DIN 69871



### Schrumpffutter zum Spannen von HM und HSS Werkzeugschäften

Shrink chucks for mounting of solid carbide and HSS-tool shanks  
Mandrins de frettage pour le serrage de queues d'outils carbures de type HM et HSS

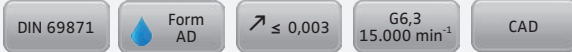

Bestell-Nr. Order no. / Référence	Abmessung Size / Dimension	Euro
302.70.03	SK 30 - 03 - 80	252,00
302.70.04	SK 30 - 04 - 80	252,00
302.70.05	SK 30 - 05 - 80	252,00
302.70.06	SK 30 - 06 - 80	207,00
302.70.08	SK 30 - 08 - 80	207,00
302.70.10	SK 30 - 10 - 80	207,00
302.70.12	SK 30 - 12 - 100	207,00
302.70.14	SK 30 - 14 - 100	207,00
302.70.16	SK 30 - 16 - 100	207,00
302.70.18	SK 30 - 18 - 100	207,00
302.70.20	SK 30 - 20 - 100	207,00
302.70.03.1	SK 30 - 03 - 160	287,00
302.70.04.1	SK 30 - 04 - 160	287,00
302.70.05.1	SK 30 - 05 - 160	287,00
302.70.06.1	SK 30 - 06 - 160	243,00
302.70.08.1	SK 30 - 08 - 160	243,00
302.70.10.1	SK 30 - 10 - 160	243,00
302.70.12.1	SK 30 - 12 - 160	243,00
302.70.14.1	SK 30 - 14 - 160	243,00
302.70.16.1	SK 30 - 16 - 160	243,00
302.70.18.1	SK 30 - 18 - 160	243,00
302.70.20.1	SK 30 - 20 - 160	243,00



### Schrumpffutter zum Spannen von HM und HSS Werkzeugschäften

Shrink chucks for mounting of solid carbide and HSS-tool shanks  
Mandrins de frettage pour le serrage de queues d'outils carbures de type HM et HSS

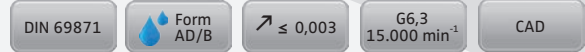

Bestell-Nr. Order no. / Référence	Abmessung Size / Dimension	Euro
403.70.03	SK 40 - 03 - 80	151,00
403.70.04	SK 40 - 04 - 80	151,00
403.70.05	SK 40 - 05 - 80	151,00
403.70.06	SK 40 - 06 - 80	136,00
403.70.08	SK 40 - 08 - 80	136,00
403.70.10	SK 40 - 10 - 80	136,00
403.70.12	SK 40 - 12 - 80	136,00
403.70.14	SK 40 - 14 - 80	136,00
403.70.16	SK 40 - 16 - 80	136,00
403.70.18	SK 40 - 18 - 80	136,00
403.70.20	SK 40 - 20 - 80	136,00
403.70.25	SK 40 - 25 - 100	136,00
403.70.32	SK 40 - 32 - 100	136,00
403.70.03.1	SK 40 - 03 - 120	254,00
403.70.04.1	SK 40 - 04 - 120	254,00
403.70.05.1	SK 40 - 05 - 120	254,00
403.70.06.1	SK 40 - 06 - 120	205,00
403.70.08.1	SK 40 - 08 - 120	205,00
403.70.10.1	SK 40 - 10 - 120	205,00
403.70.12.1	SK 40 - 12 - 120	205,00
403.70.14.1	SK 40 - 14 - 120	205,00
403.70.16.1	SK 40 - 16 - 120	205,00
403.70.18.1	SK 40 - 18 - 120	205,00
403.70.20.1	SK 40 - 20 - 120	205,00
403.70.25.1	SK 40 - 25 - 120	205,00
403.70.32.1	SK 40 - 32 - 120	205,00
403.70.03.2	SK 40 - 03 - 160	267,00
403.70.04.2	SK 40 - 04 - 160	267,00
403.70.05.2	SK 40 - 05 - 160	267,00
403.70.06.2	SK 40 - 06 - 160	225,00
403.70.08.2	SK 40 - 08 - 160	225,00
403.70.10.2	SK 40 - 10 - 160	225,00
403.70.12.2	SK 40 - 12 - 160	225,00
403.70.14.2	SK 40 - 14 - 160	225,00
403.70.16.2	SK 40 - 16 - 160	225,00
403.70.18.2	SK 40 - 18 - 160	225,00
403.70.20.2	SK 40 - 20 - 160	225,00
403.70.25.2	SK 40 - 25 - 160	225,00
403.70.32.2	SK 40 - 32 - 160	225,00



Внимание! Данный прайс-лист для европейского рынка.  
Цены в РФ значительно отличаются от цен, указанных в данном документе!  
Для получения актуальной стоимости, обращайтесь по контактам, указанным ниже.



## Werkzeugaufnahmen DIN 69871

Toolholders DIN 69871

Porte-outils DIN 69871



### Schrumpffutter zum Spannen von HM und HSS Werkzeugschäften

Shrink chucks for mounting of solid carbide and HSS-tool shanks

Mandrins de frettage pour le serrage de queues d'outils carbures de type HM et HSS

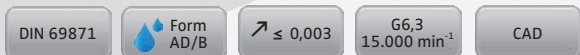

Bestell-Nr. Order no. / Référence	Abmessung Size / Dimension	Euro
503.70.03	SK 50 - 03 - 80	283,00
503.70.04	SK 50 - 04 - 80	283,00
503.70.05	SK 50 - 05 - 80	283,00
503.70.06	SK 50 - 06 - 80	258,00
503.70.08	SK 50 - 08 - 80	258,00
503.70.10	SK 50 - 10 - 80	258,00
503.70.12	SK 50 - 12 - 80	258,00
503.70.14	SK 50 - 14 - 80	258,00
503.70.16	SK 50 - 16 - 80	258,00
503.70.18	SK 50 - 18 - 80	258,00
503.70.20	SK 50 - 20 - 80	258,00
503.70.25	SK 50 - 25 - 100	258,00
503.70.32	SK 50 - 32 - 100	258,00
503.70.06.1	SK 50 - 06 - 160	277,00
503.70.08.1	SK 50 - 08 - 160	277,00
503.70.10.1	SK 50 - 10 - 160	277,00
503.70.12.1	SK 50 - 12 - 160	277,00
503.70.14.1	SK 50 - 14 - 160	277,00
503.70.16.1	SK 50 - 16 - 160	277,00
503.70.18.1	SK 50 - 18 - 160	277,00
503.70.20.1	SK 50 - 20 - 160	277,00
503.70.25.1	SK 50 - 25 - 160	277,00
503.70.32.1	SK 50 - 32 - 160	277,00

503.70.06.2	SK 50 - 06 - 200	300,00
503.70.08.2	SK 50 - 08 - 200	300,00
503.70.10.2	SK 50 - 10 - 200	300,00
503.70.12.2	SK 50 - 12 - 200	300,00
503.70.14.2	SK 50 - 14 - 200	300,00
503.70.16.2	SK 50 - 16 - 200	300,00
503.70.18.2	SK 50 - 18 - 200	300,00
503.70.20.2	SK 50 - 20 - 200	300,00
503.70.25.2	SK 50 - 25 - 200	300,00
503.70.32.2	SK 50 - 32 - 200	300,00



### Schrumpffutter mit Kühlkanälen zum Spannen von HM und HSS Werkzeugschäften

Shrink chucks with cooling channels for mounting of solid carbide and HSS-tool shanks

Mandrins de frettage avec canaux d'arrosage pour le serrage de queues d'outils carbures de type HM et HSS

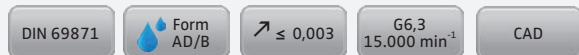

Bestell-Nr. Order no. / Référence	Abmessung Size / Dimension	Euro
403.70.06.K	SK 40 - 06 - 80	242,00
403.70.08.K	SK 40 - 08 - 80	242,00
403.70.10.K	SK 40 - 10 - 80	242,00
403.70.12.K	SK 40 - 12 - 80	242,00
403.70.14.K	SK 40 - 14 - 80	242,00
403.70.16.K	SK 40 - 16 - 80	242,00
403.70.18.K	SK 40 - 18 - 80	242,00
403.70.20.K	SK 40 - 20 - 80	242,00
403.70.25.K	SK 40 - 25 - 100	242,00
403.70.32.K	SK 40 - 32 - 100	242,00

503.70.06.K	SK 50 - 06 - 80	363,00
503.70.08.K	SK 50 - 08 - 80	363,00
503.70.10.K	SK 50 - 10 - 80	363,00
503.70.12.K	SK 50 - 12 - 80	363,00
503.70.14.K	SK 50 - 14 - 80	363,00
503.70.16.K	SK 50 - 16 - 80	363,00
503.70.18.K	SK 50 - 18 - 80	363,00
503.70.20.K	SK 50 - 20 - 80	363,00
503.70.25.K	SK 50 - 25 - 100	363,00
503.70.32.K	SK 50 - 32 - 100	363,00



### Schrumpfverlängerungen (mit Anschlag)

Shrink fit extensions (with end stop)  
Rallonges de frettage (avec butée)



Bestell-Nr. Order no. / Référence	Abmessung Size / Dimension	Euro
120.70.03	20 - 03 - 150	123,00
120.70.04	20 - 04 - 150	123,00
120.70.05	20 - 05 - 150	123,00
120.70.06	20 - 06 - 150	123,00
120.70.08	20 - 08 - 150	123,00
120.70.10	20 - 10 - 150	123,00
120.70.12	20 - 12 - 150	123,00

Внимание! Данный прайс-лист для европейского рынка.

Цены в РФ значительно отличаются от цен, указанных в данном документе!

Для получения актуальной стоимости, обращайтесь по контактам, указанным ниже.

kemmler@kemmler.su  
www.kemmler.su

## Werkzeugaufnahmen DIN 69871

Toolholders DIN 69871

Porte-outils DIN 69871



**Kontrolldorne**  
Test arbors  
Mandrins de contrôle

DIN 69871

Form  
A

↗ ≤ 0,003

CAD

Bestell-Nr. Order no. / Référence	Abmessung Size / Dimension	Euro
302.18.32	SK 30 - 32 - 300	350,00
402.18.40	SK 40 - 40 - 300	336,00
502.18.50	SK 50 - 50 - 300	506,00



**Holzkasten für Kontrolldorne**  
Wooden box for test arbors  
Coffret en bois pour mandrins de contrôle

Bestell-Nr. Order no. / Référence	Abmessung Size / Dimension	Euro
701.18	460 x 130 x115	96,00

## Gewuchtete Ausführung

Balanced type

Type équilibré



Bestell-Nr. Order no. / Référence	Abmessung Size / Dimension	Euro
--------------------------------------	-------------------------------	------

### Wuchten auf G 2,5 von vorgewuchteten Kemmler-Werkzeugen

Balancing at G 2.5 of pre-balanced Kemmler-tools  
Équilibrage sur G 2,5 d'outils Kemmler pré-équilibrés

W25	<b>Ohne Wuchtprotokoll</b> Without balancing report Sans protocole d'équilibrage	15,00
W25.2	<b>Mit Wuchtprotokoll</b> With balancing report Avec protocole d'équilibrage	19,00

### Wuchten von nicht vorgewuchteten Werkzeugen

Balancing of unbalanced tools  
Équilibrage d'outils non-équilibrés

W25.1	<b>Ohne Wuchtprotokoll</b> Without balancing report Sans protocole d'équilibrage	28,00
-------	----------------------------------------------------------------------------------------	-------

Внимание! Данный прайс-лист для европейского рынка.  
Цены в РФ значительно отличаются от цен, указанных в данном документе!  
Для получения актуальной стоимости, обращайтесь по контактам, указанным ниже.



## Werkzeugaufnahmen JIS B 6339 (MAS 403 BT)

Toolholders JIS B 6339 (MAS 403 BT)

Porte-outils JIS B 6339 (MAS 403 BT)

Vorgewuchtet

Pre-balanced

Pré-équilibré

G 6,3 15.000 min<sup>-1</sup>

G 2,5 Feinwuchten gegen Aufpreis

G 2,5 Fine balancing at extra charge

G 2,5 Equilibrage fin contre un supplément

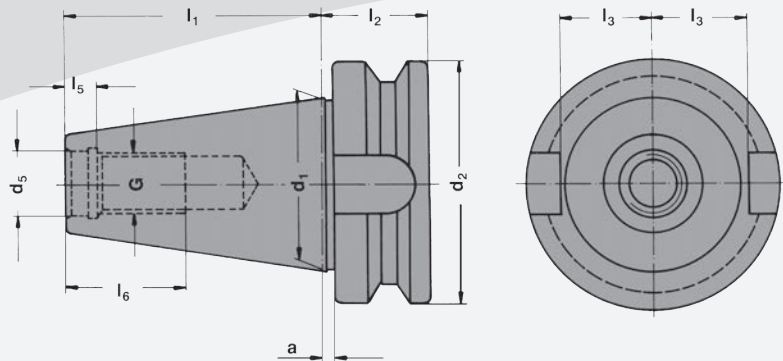

SK	d <sub>1</sub>	G	d <sub>5</sub>	d <sub>2</sub>	a	l <sub>1</sub>	l <sub>2</sub>	l <sub>3</sub>	l <sub>5</sub>	l <sub>6</sub>	e	d <sub>6</sub>
30	31,75	M12	12,5	46	2	48,4	22	16,3	7,0	24	-	-
40	44,45	M16	17,0	63	2	65,4	27	22,5	8,2	32	27	M4
50	69,85	M24	25,0	100	3	101,8	38	35,3	11,0	47	42	M6

### Mit innerer Kühlmittelzufuhr über den Bund - Form AD/B

With internal coolant through the collar - form AD/B

Avec arrosage interne par la collerette - forme AD/B

Bei Lieferung mit Gewindestiften verschlossen

Delivery with headless screws in closed position

Livraison en état fermé avec de vis sans tête

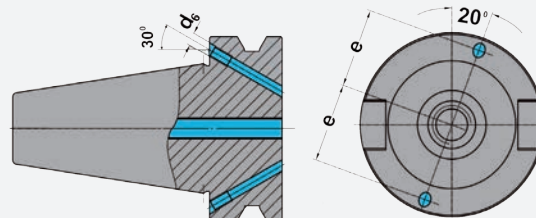

**Werkstoff:** Legierter Einsatzstahl mit einer Zugfestigkeit im Kern von min. 1200 N / mm<sup>2</sup>. Einsatzgehärtet HRC 60 ± 2 (HV 700 ± 50), Härtetiefe 0,8 mm ± 0,2 mm, brüniert und präzisionsgeschliffen.

**Form AD/B:** Lieferung in Ausführung AD, Form B mit lösbaren Gewindestiften verschlossen.

**Genauigkeit:** Kegelwinkel – Toleranzqualität < AT 3 nach DIN 7187 und DIN 2080.

**Material:** Alloyed case-hardened steel, tensile core strength of min. 1200 N / mm<sup>2</sup>. Case hardened HRC 60 ± 2 (HV 700 ± 50), hardening depth 0.8 mm ± 0.2 mm, black-finished and precisely grinded.

**Form AD/B:** Delivery in form AD, type B closed with releasable headless screws.

**Accuracy:** Quality of taper < AT 3 according to DIN 7187 and DIN 2080.

**Matière:** Acier de cémentation allié. Résistance à la traction dans le noyau de min 1200 N / mm<sup>2</sup>.

Cémentation à HRC 60 ± 2 (HV 700 ± 50), profondeur de cémentation 0,8 mm ± 0,2 mm, bruni et rectifié précisément.

**Forme AD/B:** Livraison en forme AD, forme B fermée avec de vis sans tête amovibles.

**Précision:** Qualité du cône < AT 3 selon DIN 7187 et DIN 2080.

Внимание! Данный прайс-лист для европейского рынка.

Цены в РФ значительно отличаются от цен, указанных в данном документе!

Для получения актуальной стоимости, обращайтесь по контактам, указанным ниже.

kemmler@kemmler.su

www.kemmler.su



# Inhaltsverzeichnis

Index

Table de matières

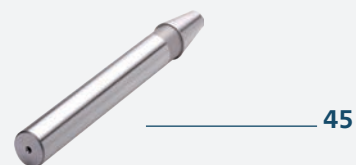

Внимание! Данный прайс-лист для европейского рынка.  
Цены в РФ значительно отличаются от цен, указанных в данном документе!  
Для получения актуальной стоимости, обращайтесь по контактам, указанным ниже.

kemmler@kemmler.su  
www.kemmler.su



## Werkzeugaufnahmen JIS B 6339 (MAS 403 BT)

Toolholders JIS B 6339 (MAS 403 BT)

Porte-outils JIS B 6339 (MAS 403 BT)



### Spannfutter für Spannzangen DIN 6499 (ISO 15488) System ER

Collet chucks for collets DIN 6499  
(ISO 15488) ER-system

Mandrins à pinces pour pinces  
DIN 6499 (ISO 15488) système ER

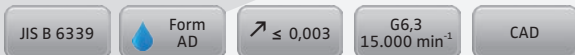

Bestell-Nr. Order no. / Réf.	Abmessung Size / Dimension	Euro
405.02.10	BT 40 - 1 / 10 - 63 ER 16	46,00
405.02.13	BT 40 - 2 / 13 - 70 ER 20	46,00
405.02.16	BT 40 - 2 / 16 - 60 ER 25	46,00
405.02.20	BT 40 - 2 / 20 - 70 ER 32	48,00
405.02.26	BT 40 - 3 / 26 - 80 ER 40	51,00
405.02.10.1	BT 40 - 1 / 10 - 100 ER 16	52,00
405.02.13.1	BT 40 - 2 / 13 - 100 ER 20	58,00
405.02.16.1	BT 40 - 2 / 16 - 100 ER 25	58,00
405.02.20.1	BT 40 - 2 / 20 - 100 ER 32	58,00
405.02.26.1	BT 40 - 3 / 26 - 100 ER 40	66,00



### Spannfutter für Spannzangen DIN 6388 (ISO 10897) System OZ

Collet chucks DIN 6391 for collets  
DIN 6388 (ISO 10897) OZ-system

Mandrins à pinces DIN 6391  
pour pinces DIN 6388 (ISO 10897)  
système OZ

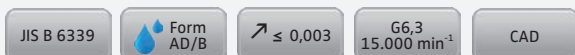

Bestell-Nr. Order no. / Référence	Abmessung Size / Dimension	Euro
305.01.16*	BT 30 - 2 / 16 - 60 OZ 16	59,00
305.01.25*	BT 30 - 2 / 25 - 80 OZ 25	60,00
406.01.16	BT 40 - 2 / 16 - 70 OZ 16	59,00
406.01.25	BT 40 - 2 / 25 - 70 OZ 25	60,00
406.01.32	BT 40 - 3 / 32 - 90 OZ 32	63,00
506.01.25	BT 50 - 2 / 25 - 85 OZ 25	83,00
506.01.32	BT 50 - 3 / 32 - 90 OZ 32	88,00

\* Form AD | \* Form AD | \* Forme AD



### Spannfutter für Spannzangen DIN 6499 (ISO 15488) System ER

Collet chucks for collets DIN 6499  
(ISO 15488) ER-system

Mandrins à pinces pour pinces  
DIN 6499 (ISO 15488) système ER

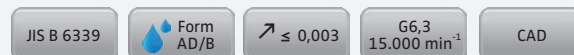

Bestell-Nr. Order no. / Réf.	Abmessung Size / Dimension	Euro
305.02.10*	BT 30 - 1 / 10 - 70 ER 16	48,00
305.02.13*	BT 30 - 2 / 13 - 70 ER 20	48,00
305.02.16*	BT 30 - 2 / 16 - 70 ER 25	48,00
305.02.20*	BT 30 - 2 / 20 - 70 ER 32	50,00
305.02.26*	BT 30 - 3 / 26 - 70 ER 40	53,00
305.02.10.1*	BT 30 - 1 / 10 - 100 ER 16	54,00
305.02.13.1*	BT 30 - 2 / 13 - 100 ER 20	76,00
305.02.16.1*	BT 30 - 2 / 16 - 100 ER 25	76,00
305.02.20.1*	BT 30 - 2 / 20 - 100 ER 32	76,00
406.02.10	BT 40 - 1 / 10 - 63 ER 16	48,00
406.02.13	BT 40 - 2 / 13 - 70 ER 20	48,00
406.02.16	BT 40 - 2 / 16 - 60 ER 25	48,00
406.02.20	BT 40 - 2 / 20 - 70 ER 32	50,00
406.02.26	BT 40 - 3 / 26 - 80 ER 40	53,00
406.02.10.1	BT 40 - 1 / 10 - 100 ER 16	54,00
406.02.13.1	BT 40 - 2 / 13 - 100 ER 20	60,00
406.02.16.1	BT 40 - 2 / 16 - 100 ER 25	60,00
406.02.20.1	BT 40 - 2 / 20 - 100 ER 32	60,00
406.02.26.1	BT 40 - 3 / 26 - 100 ER 40	67,00
406.02.10.2	BT 40 - 1 / 10 - 160 ER 16	90,00
406.02.13.2	BT 40 - 2 / 13 - 160 ER 20	90,00
406.02.16.2	BT 40 - 2 / 16 - 160 ER 25	90,00
406.02.20.2	BT 40 - 2 / 20 - 160 ER 32	92,00
406.02.26.2	BT 40 - 3 / 26 - 160 ER 40	97,00
406.02.10.3	BT 40 - 1 / 10 - 200 ER 16	133,00
406.02.13.3	BT 40 - 2 / 13 - 200 ER 20	133,00
406.02.16.3	BT 40 - 2 / 16 - 200 ER 25	133,00
406.02.20.3	BT 40 - 2 / 20 - 200 ER 32	137,00
406.02.26.3	BT 40 - 3 / 26 - 200 ER 40	146,00

\* Form AD | \* Form AD | \* Forme AD





## Werkzeugaufnahmen JIS B 6339 (MAS 403 BT)

Toolholders JIS B 6339 (MAS 403 BT)

Porte-outils JIS B 6339 (MAS 403 BT)



### Spannfutter für Spannzangen DIN 6499 (ISO 15488) System ER

Collet chucks for collets DIN 6499  
(ISO 15488) ER-system

Mandrins à pinces pour pinces  
DIN 6499 (ISO 15488) système ER

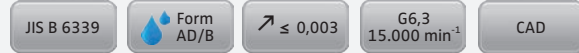

Bestell-Nr. Order no. / Réf.	Abmessung Size / Dimension	Euro
506.02.13	BT 50 - 2 / 13 - 70 ER 20	73,00
506.02.16	BT 50 - 2 / 16 - 60 ER 25	73,00
506.02.20	BT 50 - 2 / 20 - 70 ER 32	77,00
506.02.26	BT 50 - 3 / 26 - 80 ER 40	77,00
506.02.10.1	BT 50 - 1 / 10 - 100 ER 16	90,00
506.02.13.1	BT 50 - 2 / 13 - 100 ER 20	90,00
506.02.16.1	BT 50 - 2 / 16 - 100 ER 25	90,00
506.02.20.1	BT 50 - 2 / 20 - 100 ER 32	105,00
506.02.26.1	BT 50 - 3 / 26 - 100 ER 40	109,00
506.02.10.2	BT 50 - 1 / 10 - 160 ER 16	122,00
506.02.13.2	BT 50 - 2 / 13 - 160 ER 20	122,00
506.02.16.2	BT 50 - 2 / 16 - 160 ER 25	122,00
506.02.20.2	BT 50 - 2 / 20 - 160 ER 32	122,00
506.02.26.2	BT 50 - 3 / 26 - 160 ER 40	125,00
506.02.10.3	BT 50 - 1 / 10 - 200 ER 16	165,00
506.02.13.3	BT 50 - 2 / 13 - 200 ER 20	165,00
506.02.16.3	BT 50 - 2 / 16 - 200 ER 25	165,00
506.02.20.3	BT 50 - 2 / 20 - 200 ER 32	173,00
506.02.26.3	BT 50 - 3 / 26 - 200 ER 40	184,00



### Spannfutter für Spannzangen DIN 6499 (ISO 15488) System ER

Collet chucks for collets DIN 6499  
(ISO 15488) ER-system

Mandrins à pinces pour pinces  
DIN 6499 (ISO 15488) système ER

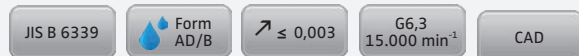

Bestell-Nr. Order no. / Réf.	Abmessung Size / Dimension	Euro
305.02.07*	BT 30 - 1 / 7 - 70 ER 11	87,00
305.02.07.1*	BT 30 - 1 / 7 - 100 ER 11	104,00
305.02.07.10*	BT 30 - 1 / 10 - 70 ER 16	87,00
305.02.07.10.1*	BT 30 - 1 / 10 - 100 ER 16	104,00
406.02.07	BT 40 - 1 / 7 - 55 ER 11	87,00
406.02.07.1	BT 40 - 1 / 7 - 100 ER 11	104,00
406.02.07.2	BT 40 - 1 / 7 - 160 ER 11	120,00
406.02.07.10	BT 40 - 1 / 10 - 55 ER 16	87,00
406.02.07.10.1	BT 40 - 1 / 10 - 100 ER 16	104,00
406.02.07.10.2	BT 40 - 1 / 10 - 160 ER 16	120,00

Mit Minimutter | With mini nut | Avec écrous-mini

\* Form AD | \* Form AD | \* Forme AD



### Spannfutter für Spannzangen System KPS

Collet chucks for collets KPS-system

Mandrins à pinces pour pinces  
système KPS

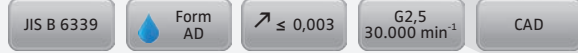

Bestell-Nr. Order no. / Réf.	Abmessung Size / Dimension	Euro
305.03.10	BT 30 - 1 / 10 - 60 KPS 10	104,00
305.03.16	BT 30 - 4 / 16 - 60 KPS 16	120,00
305.03.10.1	BT 30 - 1 / 10 - 90 KPS 10	109,00
305.03.16.1	BT 30 - 4 / 16 - 90 KPS 16	129,00
405.03.10	BT 40 - 1 / 10 - 60 KPS 10	114,00
405.03.16	BT 40 - 4 / 16 - 60 KPS 16	116,00
405.03.10.1	BT 40 - 1 / 10 - 90 KPS 10	122,00
405.03.16.1	BT 40 - 4 / 16 - 90 KPS 16	124,00
405.03.10.2	BT 40 - 1 / 10 - 120 KPS 10	131,00
405.03.16.2	BT 40 - 4 / 16 - 120 KPS 16	133,00
505.03.10	BT 50 - 1 / 10 - 105 KPS 10	213,00
505.03.16	BT 50 - 4 / 16 - 105 KPS 16	217,00
505.03.10.1	BT 50 - 1 / 10 - 135 KPS 10	228,00
505.03.16.1	BT 50 - 4 / 16 - 135 KPS 16	237,00
505.03.10.2	BT 50 - 1 / 10 - 165 KPS 10	248,00
505.03.16.2	BT 50 - 4 / 16 - 165 KPS 16	257,00



### Hochleistungs-Kraftspannfutter System HKS

High Performance Milling Chuck

HKS-system

Mandrin de serrage  
à haute performance système HKS

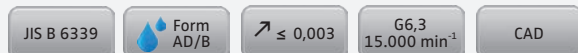

Bestell-Nr. Order no. / Référence	Abmessung Size / Dimension	Euro
406.64.20	BT 40 - 20 - 90	205,00
406.64.32	BT 40 - 32 - 90	216,00
506.64.20	BT 50 - 20 - 95	263,00
506.64.32	BT 50 - 32 - 90	273,00



Внимание! Данный прайс-лист для европейского рынка.

Цены в РФ значительно отличаются от цен, указанных в данном документе!

Для получения актуальной стоимости, обращайтесь по контактам, указанным ниже.

kemmler@kemmler.su  
www.kemmler.su

KEMMLER



## Werkzeugaufnahmen JIS B 6339 (MAS 403 BT)

Toolholders JIS B 6339 (MAS 403 BT)

Porte-outils JIS B 6339 (MAS 403 BT)



### Fräseraufnahmen DIN 6359 für Zylinderschäfte DIN 1835-B

End mill holders DIN 6359  
for end mills DIN 1835-B  
Porte-fraises DIN 6359 pour queues  
cylindriques DIN 1835-B

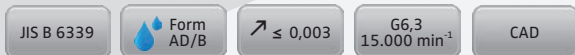

Bestell-Nr. Order no. / Référence	Abmessung Size / Dimension	Euro
305.04.06*	BT 30 - 06 - 50	39,00
305.04.08*	BT 30 - 08 - 50	36,00
305.04.10*	BT 30 - 10 - 50	36,00
305.04.12*	BT 30 - 12 - 50	36,00
305.04.14*	BT 30 - 14 - 50	36,00
305.04.16*	BT 30 - 16 - 63	36,00
305.04.18*	BT 30 - 18 - 63	36,00
305.04.20*	BT 30 - 20 - 63	36,00

406.04.16.0	BT 40 - 16 - 35	44,00
406.04.20.0	BT 40 - 20 - 35	44,00
406.04.25.0	BT 40 - 25 - 35	50,00
406.04.32.0	BT 40 - 32 - 65	53,00
406.04.06	BT 40 - 06 - 50	39,00
406.04.08	BT 40 - 08 - 50	36,00
406.04.10	BT 40 - 10 - 63	36,00
406.04.12	BT 40 - 12 - 63	36,00
406.04.14	BT 40 - 14 - 63	36,00
406.04.16	BT 40 - 16 - 63	36,00
406.04.18	BT 40 - 18 - 63	36,00
406.04.20	BT 40 - 20 - 63	36,00
406.04.25	BT 40 - 25 - 90	44,00
406.04.32	BT 40 - 32 - 100	46,00
406.04.40	BT 40 - 40 - 120	56,00
406.04.06.1	BT 40 - 06 - 100	47,00
406.04.08.1	BT 40 - 08 - 100	44,00
406.04.10.1	BT 40 - 10 - 100	44,00
406.04.12.1	BT 40 - 12 - 100	44,00
406.04.14.1	BT 40 - 14 - 100	44,00
406.04.16.1	BT 40 - 16 - 100	44,00
406.04.18.1	BT 40 - 18 - 100	44,00
406.04.20.1	BT 40 - 20 - 100	44,00
406.04.06.2	BT 40 - 06 - 160	83,00
406.04.08.2	BT 40 - 08 - 160	80,00
406.04.10.2	BT 40 - 10 - 160	80,00
406.04.12.2	BT 40 - 12 - 160	80,00
406.04.14.2	BT 40 - 14 - 160	80,00
406.04.16.2	BT 40 - 16 - 160	80,00
406.04.18.2	BT 40 - 18 - 160	80,00
406.04.20.2	BT 40 - 20 - 160	80,00
406.04.25.2	BT 40 - 25 - 160	87,00
406.04.32.2	BT 40 - 32 - 160	95,00
406.04.40.2	BT 40 - 40 - 160	103,00

\* Form AD | \* Form AD | \* Forme AD



### Fräseraufnahmen DIN 6359 für Zylinderschäfte DIN 1835-B

End mill holders DIN 6359  
for end mills DIN 1835-B  
Porte-fraises DIN 6359 pour queues  
cylindriques DIN 1835-B

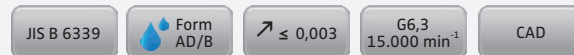

Bestell-Nr. Order no. / Référence	Abmessung Size / Dimension	Euro
506.04.06	BT 50 - 06 - 63	55,00
506.04.08	BT 50 - 08 - 63	53,00
506.04.10	BT 50 - 10 - 63	53,00
506.04.12	BT 50 - 12 - 80	53,00
506.04.14	BT 50 - 14 - 80	53,00
506.04.16	BT 50 - 16 - 80	53,00
506.04.18	BT 50 - 18 - 80	53,00
506.04.20	BT 50 - 20 - 80	53,00
506.04.25	BT 50 - 25 - 100	59,00
506.04.32	BT 50 - 32 - 105	63,00
506.04.40	BT 50 - 40 - 110	69,00
506.04.06.1	BT 50 - 06 - 100	98,00
506.04.08.1	BT 50 - 08 - 100	96,00
506.04.10.1	BT 50 - 10 - 100	96,00
506.04.12.1	BT 50 - 12 - 100	96,00
506.04.14.1	BT 50 - 14 - 100	96,00
506.04.16.1	BT 50 - 16 - 100	96,00
506.04.18.1	BT 50 - 18 - 100	96,00
506.04.20.1	BT 50 - 20 - 100	96,00
506.04.06.2	BT 50 - 06 - 160	119,00
506.04.08.2	BT 50 - 08 - 160	115,00
506.04.10.2	BT 50 - 10 - 160	115,00
506.04.12.2	BT 50 - 12 - 160	115,00
506.04.14.2	BT 50 - 14 - 160	115,00
506.04.16.2	BT 50 - 16 - 160	115,00
506.04.18.2	BT 50 - 18 - 160	115,00
506.04.20.2	BT 50 - 20 - 160	115,00
506.04.25.2	BT 50 - 25 - 160	119,00
506.04.32.2	BT 50 - 32 - 160	122,00
506.04.40.2	BT 50 - 40 - 160	136,00



110

Внимание! Данный прайс-лист для европейского рынка.

Цены в РФ значительно отличаются от цен, указанных в данном документе!

Для получения актуальной стоимости, обращайтесь по контактам, указанным ниже.

kemmler@kemmler.su  
www.kemmler.su



## Werkzeugaufnahmen JIS B 6339 (MAS 403 BT)

Toolholders JIS B 6339 (MAS 403 BT)

Porte-outils JIS B 6339 (MAS 403 BT)



### Fräseraufnahmen DIN 6359 für Zylinderschäfte DIN 1835-B

End mill holders DIN 6359 for end mills DIN 1835-B  
Porte-fraises DIN 6359 pour queues cylindriques DIN 1835-B

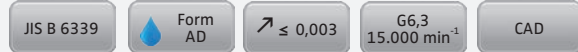

Bestell-Nr. Order no. / Référence	Abmessung Size / Dimension	Euro
405.04.06	BT 40 - 06 - 50	34,00
405.04.08	BT 40 - 08 - 50	32,00
405.04.10	BT 40 - 10 - 63	32,00
405.04.12	BT 40 - 12 - 63	32,00
405.04.14	BT 40 - 14 - 63	32,00
405.04.16	BT 40 - 16 - 63	32,00
405.04.18	BT 40 - 18 - 63	32,00
405.04.20	BT 40 - 20 - 63	32,00
405.04.25	BT 40 - 25 - 90	37,00
405.04.32	BT 40 - 32 - 100	39,00

405.04.06.1	BT 40 - 06 - 100	45,00
405.04.08.1	BT 40 - 08 - 100	42,00
405.04.10.1	BT 40 - 10 - 100	42,00
405.04.12.1	BT 40 - 12 - 100	42,00
405.04.14.1	BT 40 - 14 - 100	42,00
405.04.16.1	BT 40 - 16 - 100	42,00
405.04.18.1	BT 40 - 18 - 100	42,00
405.04.20.1	BT 40 - 20 - 100	42,00



### Gewuchtete Ausführung

Balanced type  
Type équilibré



Bestell-Nr. Order no. / Référence	Abmessung Size / Dimension	Euro
--------------------------------------	-------------------------------	------

### Wuchten auf G 2,5 von vorgewuchteten Kemmler-Werkzeugen

Balancing at G 2.5 of pre-balanced Kemmler-tools  
Équilibrage sur G 2,5 d'outils Kemmler pré-équilibrés

W25	<b>Ohne Wuchtprotokoll</b> Without balancing report Sans protocole d'équilibrage	15,00
W25.2	<b>Mit Wuchtprotokoll</b> With balancing report Avec protocole d'équilibrage	19,00

### Wuchten von nicht vorgewuchteten Werkzeugen

Balancing of unbalanced tools  
Équilibrage d'outils non-équilibrés

W25.1	<b>Ohne Wuchtprotokoll</b> Without balancing report Sans protocole d'équilibrage	28,00
-------	----------------------------------------------------------------------------------------	-------



### Fräseraufnahmen DIN 6359 mit Kühlkanälen für Zylinderschäfte DIN 1835-B

End mill holders DIN 6359 with coolant channels for end mills DIN 1835-B  
Porte-fraises DIN 6359 avec canaux d'arrosage pour queues cylindriques DIN 1835-B

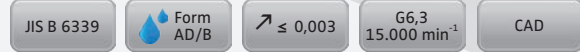

Bestell-Nr. Order no. / Référence	Abmessung Size / Dimension	Euro
406.04.06.K	BT 40 - 06 - 50	51,00
406.04.08.K	BT 40 - 08 - 50	49,00
406.04.10.K	BT 40 - 10 - 63	49,00
406.04.12.K	BT 40 - 12 - 63	49,00
406.04.14.K	BT 40 - 14 - 63	49,00
406.04.16.K	BT 40 - 16 - 63	49,00
406.04.18.K	BT 40 - 18 - 63	49,00
406.04.20.K	BT 40 - 20 - 63	49,00
406.04.25.K	BT 40 - 25 - 90	55,00
406.04.32.K	BT 40 - 32 - 100	59,00
406.04.40.K	BT 40 - 40 - 120	70,00
406.04.06.1.K	BT 40 - 06 - 100	61,00
406.04.08.1.K	BT 40 - 08 - 100	59,00
406.04.10.1.K	BT 40 - 10 - 100	59,00
406.04.12.1.K	BT 40 - 12 - 100	59,00
406.04.14.1.K	BT 40 - 14 - 100	59,00
406.04.16.1.K	BT 40 - 16 - 100	59,00
406.04.18.1.K	BT 40 - 18 - 100	59,00
406.04.20.1.K	BT 40 - 20 - 100	59,00

506.04.06.K	BT 50 - 06 - 63	77,00
506.04.08.K	BT 50 - 08 - 63	74,00
506.04.10.K	BT 50 - 10 - 63	74,00
506.04.12.K	BT 50 - 12 - 80	74,00
506.04.14.K	BT 50 - 14 - 80	74,00
506.04.16.K	BT 50 - 16 - 80	74,00
506.04.18.K	BT 50 - 18 - 80	74,00
506.04.20.K	BT 50 - 20 - 80	74,00
506.04.25.K	BT 50 - 25 - 100	80,00
506.04.32.K	BT 50 - 32 - 105	81,00
506.04.40.K	BT 50 - 40 - 110	86,00



Внимание! Данный прайс-лист для европейского рынка.  
Цены в РФ значительно отличаются от цен, указанных в данном документе!  
Для получения актуальной стоимости, обращайтесь по контактам, указанным ниже.



## Werkzeugaufnahmen JIS B 6339 (MAS 403 BT)

Toolholders JIS B 6339 (MAS 403 BT)

Porte-outils JIS B 6339 (MAS 403 BT)



### Fräseraufnahmen DIN 6359 für Zylinderschäfte DIN 1835-E Whistle Notch

End mill holders DIN 6359  
for end mills DIN 1835-E  
Whistle Notch

Porte-fraises DIN 6359 pour  
queues cylindriques DIN 1835-E  
Whistle Notch

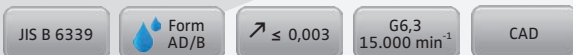

Bestell-Nr. Order no. / Référence	Abmessung Size / Dimension	Euro
406.05.06	BT 40 - 06 - 50	45,00
406.05.08	BT 40 - 08 - 50	41,00
406.05.10	BT 40 - 10 - 63	41,00
406.05.12	BT 40 - 12 - 63	41,00
406.05.14	BT 40 - 14 - 63	41,00
406.05.16	BT 40 - 16 - 63	41,00
406.05.18	BT 40 - 18 - 63	41,00
406.05.20	BT 40 - 20 - 63	41,00
406.05.25	BT 40 - 25 - 90	49,00
406.05.32	BT 40 - 32 - 100	54,00
406.05.40	BT 40 - 40 - 120	63,00
506.05.06	BT 50 - 06 - 63	62,00
506.05.08	BT 50 - 08 - 63	60,00
506.05.10	BT 50 - 10 - 63	60,00
506.05.12	BT 50 - 12 - 80	60,00
506.05.14	BT 50 - 14 - 80	60,00
506.05.16	BT 50 - 16 - 80	60,00
506.05.18	BT 50 - 18 - 80	60,00
506.05.20	BT 50 - 20 - 80	60,00
506.05.25	BT 50 - 25 - 100	67,00
506.05.32	BT 50 - 32 - 105	72,00
506.05.40	BT 50 - 40 - 110	77,00



110

### Gewuchtete Ausführung

Balanced type

Type équilibré



Bestell-Nr. Order no. / Référence	Abmessung Size / Dimension	Euro
<b>Wuchten auf G 2,5 von vorgewuchteten Kemmler-Werkzeugen</b>		
<i>Balancing at G 2.5 of pre-balanced Kemmler-tools</i>		
<i>Équilibrage sur G 2,5 d'outils Kemmler pré-équilibrés</i>		
W25	<b>Ohne Wuchtprotokoll</b> <i>Without balancing report</i> <i>Sans protocole d'équilibrage</i>	15,00
W25.2	<b>Mit Wuchtprotokoll</b> <i>With balancing report</i> <i>Avec protocole d'équilibrage</i>	19,00

### Wuchten von nicht vorgewuchteten Werkzeugen

*Balancing of unbalanced tools*

*Équilibrage d'outils non-équilibrés*

W25.1	<b>Ohne Wuchtprotokoll</b> <i>Without balancing report</i> <i>Sans protocole d'équilibrage</i>	28,00
-------	------------------------------------------------------------------------------------------------------	-------

Внимание! Данный прайс-лист для европейского рынка.

Цены в РФ значительно отличаются от цен, указанных в данном документе!

Для получения актуальной стоимости, обращайтесь по контактам, указанным ниже.

kemmler@kemmler.su  
www.kemmler.su

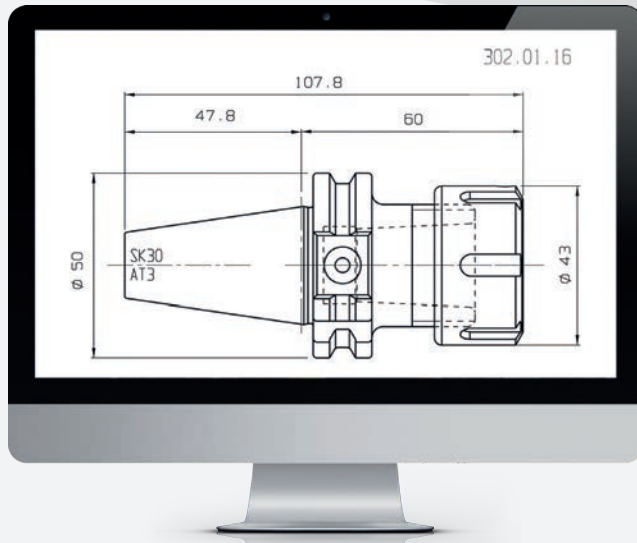

Technische Datenblätter, STEP-/STL-Modelle für die Simulation der NC-Programme und DXF-Zeichnungen zur Erstellung des Einrichteblattes stehen Online zur Verfügung.

*Technical data sheets, STEP / STL models for the simulation of NC programs and DXF drawings to create the tooling sheet are online available.*

Fiches techniques, STEP/STL modèles techniques pour la simulation de programmes CN et dessins DXF pour créer la feuille d'installation sont disponible online.



Sie können unsere Kataloge entweder direkt im Browser betrachten oder Sie auf Ihren PC, Smartphone oder Tablet herunterladen (PDF-Reader notwendig).

*You can view our catalogues either directly in the browser or download to your PC, smartphone or tablet (PDF reader required).*

Vous pouvez consulter nos catalogues directement dans le navigateur ou télécharger sur votre PC, smartphone ou tablet (lecteur PDF requis).



Auf unserer Internetseite können Sie auch die Lagerverfügbarkeit prüfen.

*On our website you can also check the stock availability.*

Sur notre site internet vous pouvez également vérifier la disponibilité du stock.

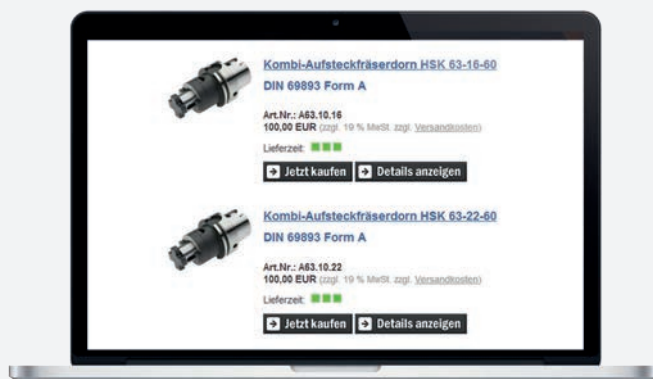

**Внимание! Данный прайс-лист для европейского рынка.**  
Цены в РФ значительно отличаются от цен, указанных в данном документе!  
Для получения актуальной стоимости, обращайтесь по контактам, указанным ниже.



## Werkzeugaufnahmen JIS B 6339 (MAS 403 BT)

Toolholders JIS B 6339 (MAS 403 BT)

Porte-outils JIS B 6339 (MAS 403 BT)



### Zwischenhülsen für MK mit Austreibblappen DIN 6383

Adaptor sleeves for MT with tang DIN 6383  
Douilles de réduction pour CM à tenon DIN 6383

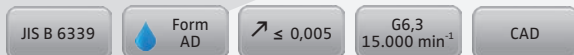

Bestell-Nr. Order no. / Référence	Abmessung Size / Dimension	Euro
405.07.01	BT 40 - 1 - 50	34,00
405.07.02	BT 40 - 2 - 50	34,00
405.07.03	BT 40 - 3 - 70	34,00
405.07.04	BT 40 - 4 - 95	37,00



87

110



### Zwischenhülsen für MK mit Anzugsgewinde DIN 6364

Adaptor sleeves for MT with drawbar thread DIN 6364  
Douilles de réduction pour CM avec filetage DIN 6364

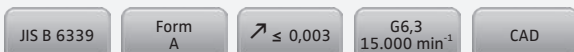

Bestell-Nr. Order no. / Référence	Abmessung Size / Dimension	Euro
405.08.01	BT 40 - 1 - 50	59,00
405.08.02	BT 40 - 2 - 50	59,00
405.08.03	BT 40 - 3 - 70	59,00
405.08.04	BT 40 - 4 - 95	63,00
405.08.04A*	BT 40 - 4 - 110	70,00
505.08.01	BT 50 - 1 - 45	77,00
505.08.02	BT 50 - 2 - 60	77,00
505.08.03	BT 50 - 3 - 65	77,00
505.08.04	BT 50 - 4 - 70	83,00
505.08.04A*	BT 50 - 4 - 85	90,00
505.08.05	BT 50 - 5 - 100	86,00
505.08.05A*	BT 50 - 5 - 118	97,00

\* Mit Mitnahmeausfräsung nach DIN 2201

\* With drive flats according to DIN 2201

\* Avec des fraises d'entraînement suivant DIN 2201



### Zwischenhülsen für MK mit Austreibblappen DIN 6383

Adaptor sleeves for MT with tang DIN 6383  
Douilles de réduction pour CM à tenon DIN 6383

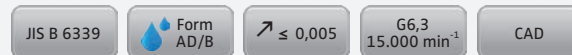

Bestell-Nr. Order no. / Référence	Abmessung Size / Dimension	Euro
305.07.01*	BT 30 - 1 - 45	36,00
305.07.02*	BT 30 - 2 - 60	36,00
305.07.03*	BT 30 - 3 - 75	36,00
406.07.01	BT 40 - 1 - 50	36,00
406.07.02	BT 40 - 2 - 50	36,00
406.07.03	BT 40 - 3 - 70	36,00
406.07.04	BT 40 - 4 - 95	40,00
506.07.01	BT 50 - 1 - 45	51,00
506.07.02	BT 50 - 2 - 60	51,00
506.07.03	BT 50 - 3 - 65	51,00
506.07.04	BT 50 - 4 - 95	51,00
506.07.05	BT 50 - 5 - 105	56,00

\*Form AD | \*Form AD | \*Forme AD



87

110



### Zwischenhülsen für SK-Aufnahmen

Adaptor sleeves for ISO-toolholders  
Douilles de réduction pour porte-outils ISO/SA

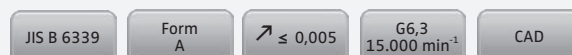

Bestell-Nr. Order no. / Référence	Abmessung Size / Dimension	Euro
405.09.30	BT 40 - SK 30 - 60	89,00
405.09.40	BT 40 - SK 40 - 100	89,00
505.09.40	BT 50 - SK 40 - 70	112,00
505.09.50	BT 50 - SK 50 - 120	129,00

Внимание! Данный прайс-лист для европейского рынка.

Цены в РФ значительно отличаются от цен, указанных в данном документе!

Для получения актуальной стоимости, обращайтесь по контактам, указанным ниже.

kemmler@kemmler.su  
www.kemmler.su



## Werkzeugaufnahmen JIS B 6339 (MAS 403 BT)

Toolholders JIS B 6339 (MAS 403 BT)

Porte-outils JIS B 6339 (MAS 403 BT)

**Quernut-Aufsteckfräserdorne  
DIN 6357 mit vergrößerter  
Anlagefläche und Kühlkanal-  
bohrungen an der Stirnseite**

Shell mill holders DIN 6357  
with enlarged contact face and  
coolant exit bores on the end face  
Porte-fraises à trou lisse DIN 6357  
avec face de contact élargie  
et conduits pour l'arrosage frontal



JIS B 6339



↗ ≤ 0,005

G6,3  
15.000 min<sup>-1</sup>

CAD

Bestell-Nr. Order no. / Référence	Abmessung Size / Dimension	Euro
405.11.16	BT 40 - 16 - 40	48,00
405.11.22	BT 40 - 22 - 40	48,00
405.11.27	BT 40 - 27 - 40	49,00
405.11.32	BT 40 - 32 - 50	52,00
405.11.40	BT 40 - 40 - 50	64,00



**Kombi-Aufsteckfräserdorne  
DIN 6358**

Combi shell mill holders DIN 6358  
Porte-fraises à double usage  
DIN 6358

JIS B 6339



↗ ≤ 0,005

G6,3  
15.000 min<sup>-1</sup>

CAD

Bestell-Nr. Order no. / Référence	Abmessung Size / Dimension	Euro
305.10.16*	BT 30 - 16 - 45	46,00
305.10.22*	BT 30 - 22 - 47	47,00
305.10.27*	BT 30 - 27 - 49	47,00
406.10.16	BT 40 - 16 - 55	46,00
406.10.22	BT 40 - 22 - 55	47,00
406.10.27	BT 40 - 27 - 55	47,00
406.10.32	BT 40 - 32 - 60	51,00
406.10.40	BT 40 - 40 - 60	58,00
406.10.16.1	BT 40 - 16 - 100	56,00
406.10.22.1	BT 40 - 22 - 100	58,00
406.10.27.1	BT 40 - 27 - 100	59,00
406.10.32.1	BT 40 - 32 - 100	61,00
406.10.40.1	BT 40 - 40 - 100	69,00
406.10.16.2	BT 40 - 16 - 160	92,00
406.10.22.2	BT 40 - 22 - 160	96,00
406.10.27.2	BT 40 - 27 - 160	100,00
406.10.32.2	BT 40 - 32 - 160	103,00
406.10.40.2	BT 40 - 40 - 160	112,00
506.10.16	BT 50 - 16 - 70	62,00
506.10.22	BT 50 - 22 - 70	62,00
506.10.27	BT 50 - 27 - 70	63,00
506.10.32	BT 50 - 32 - 70	66,00
506.10.40	BT 50 - 40 - 70	72,00
506.10.16.2	BT 50 - 16 - 160	134,00
506.10.22.2	BT 50 - 22 - 160	138,00
506.10.27.2	BT 50 - 27 - 160	145,00
506.10.32.2	BT 50 - 32 - 160	150,00
506.10.40.2	BT 50 - 40 - 160	161,00

\* Form AD | \* Form AD | \* Forme AD

**Quernut-Aufsteckfräserdorne DIN  
6357 mit vergrößerter  
Anlagefläche und Kühlkanal-  
bohrungen an der Stirnseite**

Shell mill holders DIN 6357  
with enlarged contact face and  
coolant exit bores on the end face  
Porte-fraises à trou lisse DIN 6357 avec  
face de contact élargie  
et conduits pour l'arrosage frontal



JIS B 6339



↗ ≤ 0,005

G6,3  
15.000 min<sup>-1</sup>

CAD

Bestell-Nr. Order no. / Référence	Abmessung Size / Dimension	Euro
305.11.16*	BT 30 - 16 - 40	50,00
305.11.22*	BT 30 - 22 - 40	50,00
305.11.27*	BT 30 - 27 - 40	51,00
305.11.32*	BT 30 - 32 - 50	54,00

406.11.16	BT 40 - 16 - 40	50,00
406.11.22	BT 40 - 22 - 40	50,00
406.11.27	BT 40 - 27 - 40	51,00
406.11.32	BT 40 - 32 - 50	54,00
406.11.40	BT 40 - 40 - 50	66,00
406.11.16.1	BT 40 - 16 - 100	66,00
406.11.22.1	BT 40 - 22 - 100	67,00
406.11.27.1	BT 40 - 27 - 100	68,00
406.11.32.1	BT 40 - 32 - 100	71,00
406.11.40.1	BT 40 - 40 - 100	79,00
406.11.16.2	BT 40 - 16 - 160	91,00
406.11.22.2	BT 40 - 22 - 160	93,00
406.11.27.2	BT 40 - 27 - 160	95,00
406.11.32.2	BT 40 - 32 - 160	99,00
406.11.40.2	BT 40 - 40 - 160	111,00

506.11.22	BT 50 - 22 - 40	66,00
506.11.27	BT 50 - 27 - 40	66,00
506.11.32	BT 50 - 32 - 50	70,00
506.11.40	BT 50 - 40 - 50	80,00
506.11.60	BT 50 - 60 - 80	122,00
506.11.22.1	BT 50 - 22 - 100	87,00
506.11.27.1	BT 50 - 27 - 100	87,00
506.11.32.1	BT 50 - 32 - 100	95,00
506.11.40.1	BT 50 - 40 - 100	108,00
506.11.22.2	BT 50 - 22 - 160	139,00
506.11.27.2	BT 50 - 27 - 160	139,00
506.11.32.2	BT 50 - 32 - 160	143,00
506.11.40.2	BT 50 - 40 - 160	155,00

\* Form AD | \* Form AD | \* Forme AD



125



125



110

Внимание! Данный прайс-лист для европейского рынка.

Цены в РФ значительно отличаются от цен, указанных в данном документе!

Для получения актуальной стоимости, обращайтесь по контактам, указанным ниже.

\* Form AD | \* Form AD | \* Forme AD







## Werkzeugaufnahmen JIS B 6339 (MAS 403 BT)

Toolholders JIS B 6339 (MAS 403 BT)

Porte-outils JIS B 6339 (MAS 403 BT)



**CNC-Bohrfutter  
für Rechts- und Linkslauf**  
CNC-Drill chucks for clockwise  
and counter clockwise rotation  
Mandrins de perçage CNC  
pour rotation gauche-droite

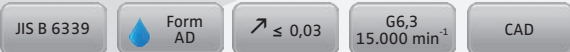

Bestell-Nr. Order no. / Référence	Abmessung Size / Dimension	Euro
305.15.08	BT 30 - 0,5 / 8 - 73	328,00
305.15.13	BT 30 - 1,0 / 13 - 93	273,00
305.15.16	BT 30 - 2,5 / 16 - 98	294,00
405.15.08	BT 40 - 0,5 / 8 - 78	246,00
405.15.13	BT 40 - 1,0 / 13 - 98	190,00
405.15.16	BT 40 - 2,5 / 16 - 103	195,00
505.15.13	BT 50 - 1,0 / 13 - 108	257,00
505.15.16	BT 50 - 2,5 / 16 - 113	273,00



127



110

**Gewindeschneid-Schnellwech-  
selfutter mit Längenausgleich  
auf Druck und Zug**

Quick change tapping chucks  
with length compensation  
on compression and expansion  
Mandrins de taraudage à change-  
ment rapide avec compensation  
longitudinale à la compression  
et traction

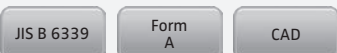

Bestell-Nr. Order no. / Référence	Abmessung Size / Dimension	Euro
305.16.12	BT 30 - M3 / M14 Gr. 1	179,00
305.16.20	BT 30 - M5 / M22 Gr. 2	191,00
405.16.12	BT 40 - M3 / M14 Gr. 1	179,00
405.16.20	BT 40 - M5 / M22 Gr. 2	191,00
405.16.36	BT 40 - M14 / M36 Gr. 3	290,00
505.16.12	BT 50 - M3 / M14 Gr. 1	223,00
505.16.20	BT 50 - M5 / M22 Gr. 2	235,00
505.16.36	BT 50 - M14 / M36 Gr. 3	334,00



116



116



117



**CNC-Bohrfutter  
für Rechts- und Linkslauf**  
CNC-Drill chucks for clockwise  
and counter clockwise rotation  
Mandrins de perçage CNC  
pour rotation gauche-droite



Bestell-Nr. Order no. / Référence	Abmessung Size / Dimension	Euro
406.15.08	BT 40 - 0,5 / 8 - 78	302,00
406.15.13	BT 40 - 1,0 / 13 - 98	257,00
406.15.16	BT 40 - 2,5 / 16 - 103	279,00
506.15.13	BT 50 - 1,0 / 13 - 108	302,00
506.15.16	BT 50 - 2,5 / 16 - 113	324,00

**Gewindeschneid-Schnellwech-  
selfutter ohne Längenausgleich  
auf Druck und Zug**

Quick change tapping chucks  
without length compensation  
on compression and expansion  
Mandrins de taraudage à change-  
ment rapide sans compensation  
longitudinale à la compression  
et traction



Bestell-Nr. Order no. / Référence	Abmessung Size / Dimension	Euro
305.16.12.1	BT 30 - M3 / M14 Gr. 1	135,00
305.16.20.1	BT 30 - M5 / M22 Gr. 2	145,00
405.16.12.1	BT 40 - M3 / M14 Gr. 1	135,00
405.16.20.1	BT 40 - M5 / M22 Gr. 2	145,00
405.16.36.1	BT 40 - M14 / M36 Gr. 3	223,00
505.16.12.1	BT 50 - M3 / M14 Gr. 1	179,00
505.16.20.1	BT 50 - M5 / M22 Gr. 2	191,00
505.16.36.1	BT 50 - M14 / M36 Gr. 3	246,00



116



116



117

Внимание! Данный прайс-лист для европейского рынка.

Цены в РФ значительно отличаются от цен, указанных в данном документе!

Для получения актуальной стоимости, обращайтесь по контактам, указанным ниже.

kemmler@kemmler.su  
www.kemmler.su

## Werkzeugaufnahmen JIS B 6339 (MAS 403 BT)

Toolholders JIS B 6339 (MAS 403 BT)

Porte-outils JIS B 6339 (MAS 403 BT)



### Bohrfutteraufnahmen DIN 238

Drill chuck adaptors DIN 238

Arbres pour mandrins de perçage  
DIN 238

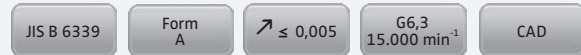

Bestell-Nr. Order no. / Référence	Abmessung Size / Dimension	Euro
305.14.12	BT 30 - B12	39,00
305.14.16	BT 30 - B16	39,00
405.14.12	BT 40 - B12	39,00
405.14.16	BT 40 - B16	39,00
405.14.18	BT 40 - B18	39,00
505.14.16	BT 50 - B16	50,00
505.14.18	BT 50 - B18	50,00



127



110



### Bohrstangenrohlinge

Boring bar blanks

Barres d'alésage

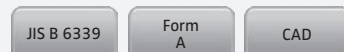

Bestell-Nr. Order no. / Référence	Abmessung Size / Dimension	Euro
305.17.40	BT 30 - 40,5 - 160	108,00
405.17.63	BT 40 - 63 - 250	110,00
505.17.97	BT 50 - 97 - 315	179,00



### Gewindeschneidfutter für Synchronisation für Spannzangen DIN 6499 (ISO 15488) System ER

Tapping chucks for synchronization for collets DIN 6499 (ISO 15488) ER-system

Mandrins de taraudage pour synchronisation pour pinces DIN 6499 (ISO 15488) système ER



Bestell-Nr. Order no. / Référence	Abmessung Size / Dimension	Euro
406.16.02.10	BT 40 - ER 16 - 79	528,00
406.16.02.13	BT 40 - ER 20 - 85	542,00
406.16.02.16	BT 40 - ER 25 - 89	542,00
406.16.02.20	BT 40 - ER 32 - 110	542,00
406.16.02.26	BT 40 - ER 40 - 115	542,00
506.16.02.10	BT 50 - ER 16 - 95	576,00
506.16.02.13	BT 50 - ER 20 - 100	576,00
506.16.02.16	BT 50 - ER 25 - 110	576,00
506.16.02.20	BT 50 - ER 32 - 120	624,00
506.16.02.26	BT 50 - ER 40 - 120	630,00



98



108



110



2

### Gewuchtete Ausführung

Balanced type

Type équilibré



Bestell-Nr. Order no. / Référence	Abmessung Size / Dimension	Euro
--------------------------------------	-------------------------------	------

### Wuchten auf G 2,5 von vorgewuchteten Kemmler-Werkzeugen

Balancing at G 2.5 of pre-balanced Kemmler-tools

Équilibrage sur G 2,5 d'outils Kemmler pré-équilibrés

W25	<b>Ohne Wuchtprotokoll</b> Without balancing report Sans protocole d'équilibrage	15,00
W25.2	<b>Mit Wuchtprotokoll</b> With balancing report Avec protocole d'équilibrage	19,00

### Wuchten von nicht vorgewuchteten Werkzeugen

Balancing of unbalanced tools

Équilibrage d'outils non-équilibrés

W25.1	<b>Ohne Wuchtprotokoll</b> Without balancing report Sans protocole d'équilibrage	28,00
-------	----------------------------------------------------------------------------------------	-------

Внимание! Данный прайс-лист для европейского рынка.  
Цены в РФ значительно отличаются от цен, указанных в данном документе!  
Для получения актуальной стоимости, обращайтесь по контактам, указанным ниже.



## Werkzeugaufnahmen JIS B 6339 (MAS 403 BT)

Toolholders JIS B 6339 (MAS 403 BT)

Porte-outils JIS B 6339 (MAS 403 BT)



### Hydro-Dehnspannfutter

Hydraulic expansion chucks

Mandrins expansibles hydrauliques

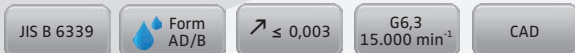

Bestell-Nr.	Abmessung	Euro
Order no. / Référence	Size / Dimension	

305.H06*	BT 30 - 06 - 60	513,00
305.H08*	BT 30 - 08 - 64	513,00
305.H10*	BT 30 - 10 - 64	513,00
305.H12*	BT 30 - 12 - 72	513,00
305.H14*	BT 30 - 14 - 70	513,00
305.H16*	BT 30 - 16 - 90	513,00
305.H18*	BT 30 - 18 - 90	513,00
305.H20*	BT 30 - 20 - 90	513,00

406.H06	BT 40 - 06 - 90	329,00
406.H08	BT 40 - 08 - 90	329,00
406.H10	BT 40 - 10 - 90	329,00
406.H12	BT 40 - 12 - 90	329,00
406.H14	BT 40 - 14 - 90	329,00
406.H16	BT 40 - 16 - 90	329,00
406.H18	BT 40 - 18 - 90	329,00
406.H20	BT 40 - 20 - 90	329,00
406.H25	BT 40 - 25 - 90	329,00
406.H32	BT 40 - 32 - 110	329,00

406.H06.1	BT 40 - 06 - 150	583,00
406.H08.1	BT 40 - 08 - 150	583,00
406.H10.1	BT 40 - 10 - 150	583,00
406.H12.1	BT 40 - 12 - 150	583,00
406.H14.1	BT 40 - 14 - 150	583,00
406.H16.1	BT 40 - 16 - 150	583,00
406.H18.1	BT 40 - 18 - 150	583,00
406.H20.1	BT 40 - 20 - 150	583,00
406.H25.1	BT 40 - 25 - 150	583,00
406.H32.1	BT 40 - 32 - 150	583,00

406.H06.2	BT 40 - 06 - 200	656,00
406.H08.2	BT 40 - 08 - 200	656,00
406.H10.2	BT 40 - 10 - 200	656,00
406.H12.2	BT 40 - 12 - 200	656,00
406.H14.2	BT 40 - 14 - 200	656,00
406.H16.2	BT 40 - 16 - 200	656,00
406.H18.2	BT 40 - 18 - 200	656,00
406.H20.2	BT 40 - 20 - 200	656,00
406.H25.2	BT 40 - 25 - 200	656,00
406.H32.2	BT 40 - 32 - 200	656,00

\* Form AD | \* Form AD | \* Forme AD



### Hydro-Dehnspannfutter

Hydraulic expansion chucks

Mandrins expansibles hydrauliques

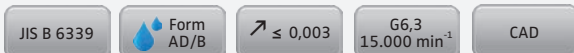

Bestell-Nr.	Abmessung	Euro
Order no. / Référence	Size / Dimension	

506.H06	BT 50 - 06 - 110	460,00
506.H08	BT 50 - 08 - 110	460,00
506.H10	BT 50 - 10 - 110	460,00
506.H12	BT 50 - 12 - 110	460,00
506.H14	BT 50 - 14 - 110	460,00
506.H16	BT 50 - 16 - 110	460,00
506.H18	BT 50 - 18 - 110	460,00
506.H20	BT 50 - 20 - 110	460,00
506.H25	BT 50 - 25 - 110	460,00
506.H32	BT 50 - 32 - 110	460,00



### Gewuchtete Ausführung

Balanced type

Type équilibré

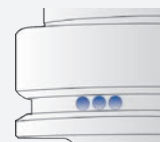

Bestell-Nr.	Abmessung	Euro
Order no. / Référence	Size / Dimension	

#### Wuchten auf G 2,5 von vorgewuchteten Kemmler-Werkzeugen

Balancing at G 2.5 of pre-balanced Kemmler-tools

Équilibrage sur G 2,5 d'outils Kemmler pré-équilibrés

W25	<b>Ohne Wuchtprotokoll</b> Without balancing report Sans protocole d'équilibrage	15,00
-----	----------------------------------------------------------------------------------------	-------

W25.2	<b>Mit Wuchtprotokoll</b> With balancing report Avec protocole d'équilibrage	19,00
-------	------------------------------------------------------------------------------------	-------

#### Wuchten von nicht vorgewuchteten Werkzeugen

Balancing of unbalanced tools

Équilibrage d'outils non-équilibrés

W25.1	<b>Ohne Wuchtprotokoll</b> Without balancing report Sans protocole d'équilibrage	28,00
-------	----------------------------------------------------------------------------------------	-------

## Werkzeugaufnahmen JIS B 6339 (MAS 403 BT)

Toolholders JIS B 6339 (MAS 403 BT)

Porte-outils JIS B 6339 (MAS 403 BT)



### Schrumpffutter zum Spannen von HM und HSS Werkzeugschäften

Shrink chucks for mounting of solid carbide and HSS-tool shanks  
Mandrins de frettage pour le serrage de queues d'outils carbures de type HM et HSS

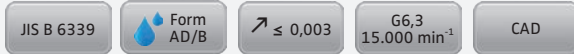

Bestell-Nr. Order no. / Référence	Abmessung Size / Dimension	Euro
305.70.03 *	BT 30 - 03 - 80	252,00
305.70.04 *	BT 30 - 04 - 80	252,00
305.70.05 *	BT 30 - 05 - 80	252,00
305.70.06 *	BT 30 - 06 - 80	207,00
305.70.08 *	BT 30 - 08 - 80	207,00
305.70.10 *	BT 30 - 10 - 90	207,00
305.70.12 *	BT 30 - 12 - 90	207,00
305.70.14 *	BT 30 - 14 - 90	207,00
305.70.16 *	BT 30 - 16 - 90	207,00
305.70.18 *	BT 30 - 18 - 90	207,00
305.70.20 *	BT 30 - 20 - 90	207,00
406.70.03	BT 40 - 03 - 80	151,00
406.70.04	BT 40 - 04 - 80	151,00
406.70.05	BT 40 - 05 - 80	151,00
406.70.06	BT 40 - 06 - 90	136,00
406.70.08	BT 40 - 08 - 90	136,00
406.70.10	BT 40 - 10 - 90	136,00
406.70.12	BT 40 - 12 - 90	136,00
406.70.14	BT 40 - 14 - 90	136,00
406.70.16	BT 40 - 16 - 90	136,00
406.70.18	BT 40 - 18 - 90	136,00
406.70.20	BT 40 - 20 - 90	136,00
406.70.25	BT 40 - 25 - 100	151,00
406.70.32	BT 40 - 32 - 100	151,00
406.70.06.1	BT 40 - 06 - 120	205,00
406.70.08.1	BT 40 - 08 - 120	205,00
406.70.10.1	BT 40 - 10 - 120	205,00
406.70.12.1	BT 40 - 12 - 120	205,00
406.70.14.1	BT 40 - 14 - 120	205,00
406.70.16.1	BT 40 - 16 - 120	205,00
406.70.18.1	BT 40 - 18 - 120	205,00
406.70.20.1	BT 40 - 20 - 120	205,00
406.70.25.1	BT 40 - 25 - 120	205,00
406.70.06.2	BT 40 - 06 - 160	225,00
406.70.08.2	BT 40 - 08 - 160	225,00
406.70.10.2	BT 40 - 10 - 160	225,00
406.70.12.2	BT 40 - 12 - 160	225,00
406.70.14.2	BT 40 - 14 - 160	225,00
406.70.16.2	BT 40 - 16 - 160	225,00
406.70.18.2	BT 40 - 18 - 160	225,00
406.70.20.2	BT 40 - 20 - 160	225,00
406.70.25.2	BT 40 - 25 - 160	225,00
406.70.32.2	BT 40 - 32 - 160	225,00



### Schrumpffutter zum Spannen von HM und HSS Werkzeugschäften

Shrink chucks for mounting of solid carbide and HSS-tool shanks  
Mandrins de frettage pour le serrage de queues d'outils carbures de type HM et HSS

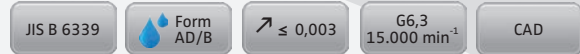

Bestell-Nr. Order no. / Référence	Abmessung Size / Dimension	Euro
506.70.04	BT 50 - 04 - 100	283,00
506.70.05	BT 50 - 05 - 100	283,00
506.70.06	BT 50 - 06 - 100	258,00
506.70.08	BT 50 - 08 - 100	258,00
506.70.10	BT 50 - 10 - 100	258,00
506.70.12	BT 50 - 12 - 100	258,00
506.70.14	BT 50 - 14 - 100	258,00
506.70.16	BT 50 - 16 - 100	258,00
506.70.18	BT 50 - 18 - 110	258,00
506.70.20	BT 50 - 20 - 110	258,00
506.70.25	BT 50 - 25 - 120	258,00
506.70.32	BT 50 - 32 - 120	258,00
506.70.06.1	BT 50 - 06 - 160	277,00
506.70.08.1	BT 50 - 08 - 160	277,00
506.70.10.1	BT 50 - 10 - 160	277,00
506.70.12.1	BT 50 - 12 - 160	277,00
506.70.14.1	BT 50 - 14 - 160	277,00
506.70.16.1	BT 50 - 16 - 160	277,00
506.70.18.1	BT 50 - 18 - 160	277,00
506.70.20.1	BT 50 - 20 - 160	277,00
506.70.25.1	BT 50 - 25 - 160	277,00
506.70.32.1	BT 50 - 32 - 160	277,00
506.70.06.2	BT 50 - 06 - 200	300,00
506.70.08.2	BT 50 - 08 - 200	300,00
506.70.10.2	BT 50 - 10 - 200	300,00
506.70.12.2	BT 50 - 12 - 200	300,00
506.70.14.2	BT 50 - 14 - 200	300,00
506.70.16.2	BT 50 - 16 - 200	300,00
506.70.18.2	BT 50 - 18 - 200	300,00
506.70.20.2	BT 50 - 20 - 200	300,00
506.70.25.2	BT 50 - 25 - 200	300,00



Внимание! Данный прайс-лист для европейского рынка.  
Цены в РФ значительно отличаются от цен, указанных в данном документе!  
Для получения актуальной стоимости, обращайтесь по контактам, указанным ниже.

\* Form AD | \* Form AD | \* Forme AD

kemmler@kemmler.su  
www.kemmler.su



## Werkzeugaufnahmen JIS B 6339 (MAS 403 BT)

Toolholders JIS B 6339 (MAS 403 BT)

Porte-outils JIS B 6339 (MAS 403 BT)

### Schrumpffutter mit Kühlkanälen zum Spannen von HM und HSS Werkzeugschäften

Shrink chucks with cooling channels for mounting of solid carbide and HSS-tool shanks

Mandrins de frettage avec canaux d'arrosage pour le serrage de queues d'outils carbures de type HM et HSS

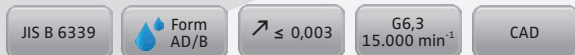

Bestell-Nr. Order no. / Référence	Abmessung Size / Dimension	Euro
406.70.06.K	BT 40 - 06 - 90	242,00
406.70.08.K	BT 40 - 08 - 90	242,00
406.70.10.K	BT 40 - 10 - 90	242,00
406.70.12.K	BT 40 - 12 - 90	242,00
406.70.14.K	BT 40 - 14 - 90	242,00
406.70.16.K	BT 40 - 16 - 90	242,00
406.70.18.K	BT 40 - 18 - 90	242,00
406.70.20.K	BT 40 - 20 - 90	242,00
406.70.25.K	BT 40 - 25 - 100	242,00
506.70.06.K	BT 50 - 06 - 100	294,00
506.70.08.K	BT 50 - 08 - 100	294,00
506.70.10.K	BT 50 - 10 - 100	294,00
506.70.12.K	BT 50 - 12 - 100	294,00
506.70.14.K	BT 50 - 14 - 100	294,00
506.70.16.K	BT 50 - 16 - 100	294,00
506.70.18.K	BT 50 - 18 - 110	294,00
506.70.20.K	BT 50 - 20 - 110	294,00



### Schrumpferverlängerungen (mit Anschlag)

Shrink fit extensions (with end stop)  
Rallonges de frettage (avec butée)

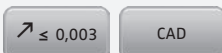

Bestell-Nr. Order no. / Référence	Abmessung Size / Dimension	Euro
120.70.03	20 - 03 - 150	123,00
120.70.04	20 - 04 - 150	123,00
120.70.05	20 - 05 - 150	123,00
120.70.06	20 - 06 - 150	123,00
120.70.08	20 - 08 - 150	123,00
120.70.10	20 - 10 - 150	123,00
120.70.12	20 - 12 - 150	123,00



### Fräsaufnahme für Einschraubfräser

Milling arbors for screw-in cutters

Porte-fraises pour fraises à queue filetée

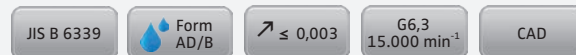

Bestell-Nr. Order no. / Référence	Abmessung Size / Dimension	Euro
406.06.06	BT 40 - M6 - 52	88,00
406.06.06.1	BT 40 - M6 - 77	100,00
406.06.06.2	BT 40 - M6 - 102	110,00
406.06.08	BT 40 - M8 - 52	88,00
406.06.08.1	BT 40 - M8 - 77	100,00
406.06.08.2	BT 40 - M8 - 102	110,00
406.06.08.3	BT 40 - M8 - 127	123,00
406.06.10	BT 40 - M10 - 52	88,00
406.06.10.1	BT 40 - M10 - 77	100,00
406.06.10.2	BT 40 - M10 - 102	110,00
406.06.10.3	BT 40 - M10 - 127	126,00
406.06.12	BT 40 - M12 - 52	88,00
406.06.12.1	BT 40 - M12 - 77	100,00
406.06.12.2	BT 40 - M12 - 102	110,00
406.06.12.3	BT 40 - M12 - 127	126,00
406.06.12.4	BT 40 - M12 - 152	143,00
406.06.16	BT 40 - M16 - 52	88,00
406.06.16.1	BT 40 - M16 - 77	100,00
406.06.16.2	BT 40 - M16 - 102	110,00
406.06.16.3	BT 40 - M16 - 127	126,00
406.06.16.4	BT 40 - M16 - 152	146,00
406.06.16.5	BT 40 - M16 - 177	160,00
506.06.08.1	BT 50 - M8 - 88	119,00
506.06.08.3	BT 50 - M8 - 138	147,00
506.06.08.5	BT 50 - M8 - 188	172,00
506.06.10.1	BT 50 - M10 - 88	119,00
506.06.10.3	BT 50 - M10 - 138	147,00
506.06.10.5	BT 50 - M10 - 188	172,00
506.06.12.1	BT 50 - M12 - 88	119,00
506.06.12.3	BT 50 - M12 - 138	147,00
506.06.12.5	BT 50 - M12 - 188	172,00
506.06.16.1	BT 50 - M16 - 88	119,00
506.06.16.2	BT 50 - M16 - 113	119,00
506.06.16.3	BT 50 - M16 - 138	147,00
506.06.16.5	BT 50 - M16 - 188	172,00



110

Внимание! Данный прайс-лист для европейского рынка.

Цены в РФ значительно отличаются от цен, указанных в данном документе!

Для получения актуальной стоимости, обращайтесь по контактам, указанным ниже.



## Werkzeugaufnahmen JIS B 6339 (MAS 403 BT)

Toolholders JIS B 6339 (MAS 403 BT)

Porte-outils JIS B 6339 (MAS 403 BT)

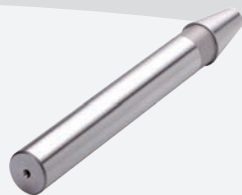

### Kontrolldorne

Test arbors

Mandrins de contrôle

JIS B 6339

Form  
A

$\nearrow \leq 0,003$

CAD

Bestell-Nr. Order no. / Référence	Abmessung Size / Dimension	Euro
305.18.32	BT 30 - 32 - 300	350,00
405.18.40	BT 40 - 40 - 300	336,00
505.18.50	BT 50 - 50 - 300	506,00



### Holzkasten für Kontrolldorne

Wooden box for test arbors

Coffret en bois pour mandrins

de contrôle

Bestell-Nr. Order no. / Référence	Abmessung Size / Dimension	Euro
701.18	460 x 130 x 115	96,00

2



### Gewuchtete Ausführung

Balanced type

Type équilibré



Bestell-Nr. Order no. / Référence	Abmessung Size / Dimension	Euro
--------------------------------------	-------------------------------	------

#### Wuchten auf G 2,5 von vorgewuchteten Kemmler-Werkzeugen

Balancing at G 2.5 of pre-balanced Kemmler-tools

Équilibrage sur G 2,5 d'outils Kemmler pré-équilibrés

W25	<b>Ohne Wuchtprotokoll</b> Without balancing report Sans protocole d'équilibrage	15,00
-----	----------------------------------------------------------------------------------------	-------

W25.2	<b>Mit Wuchtprotokoll</b> With balancing report Avec protocole d'équilibrage	19,00
-------	------------------------------------------------------------------------------------	-------

#### Wuchten von nicht vorgewuchteten Werkzeugen

Balancing of unbalanced tools

Équilibrage d'outils non-équilibrés

W25.1	<b>Ohne Wuchtprotokoll</b> Without balancing report Sans protocole d'équilibrage	28,00
-------	----------------------------------------------------------------------------------------	-------

Внимание! Данный прайс-лист для европейского рынка.  
Цены в РФ значительно отличаются от цен, указанных в данном документе!  
Для получения актуальной стоимости, обращайтесь по контактам, указанным ниже.

**KEMMLER**

45



## Werkzeugaufnahmen DIN 2080

Toolholders DIN 2080

Porte-outils DIN 2080

Vorgewuchtet

Pre-balanced

Pré-équilibré

G 6,3 15.000 min<sup>-1</sup>

G 2,5 Feinwuchten gegen Aufpreis

G 2,5 Fine balancing at extra charge

G 2,5 Equilibrage fin contre un supplément

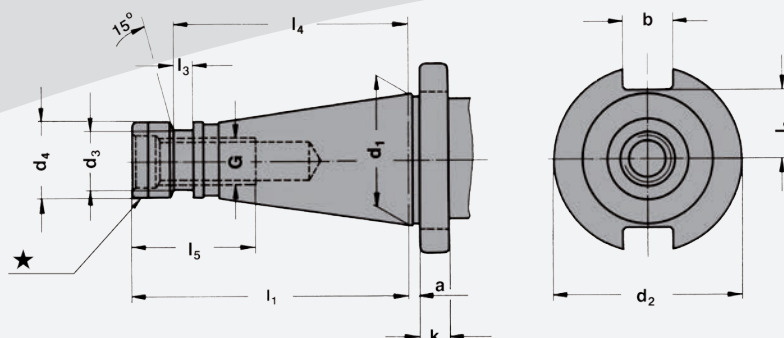

★ Mit Kunststoff-Kantenschutzring

★ With plastic protection ring

★ Avec bague de protection en plastique



SK	d <sub>1</sub>	a	b	k	G	d <sub>2</sub>	d <sub>3</sub>	d <sub>4</sub>	l <sub>1</sub>	l <sub>2</sub>	l <sub>3</sub>	l <sub>4</sub>	l <sub>5</sub>
30	31,75	1,6	16,1	8	M12	50,0	–	17,2	68,4	16,2	–	–	24,0
40 ★	44,45	1,6	16,1	10	M16	63,0	21,1	25,0	93,4	22,5	7,0	82,0	32,0
50 ★	69,85	3,2	25,7	12	M24	97,5	32,0	39,2	126,8	35,3	13,0	115,0	47,0

**Werkstoff:** Legierter Einsatzstahl mit einer Zugfestigkeit im Kern von min. 1200 N / mm<sup>2</sup>. Einsatzgehärtet HRC 60 ± 2 (HV 700 ± 50), Härtetiefe 0,8 mm ± 0,2 mm, brüniert und präzisionsgeschliffen.

**Genauigkeit:** Kegelwinkel – Toleranzqualität < AT 3 nach DIN 7187 und DIN 2080.

**Material:** Alloyed case-hardened steel, tensile core strength of min. 1200 N / mm<sup>2</sup>. Case hardened HRC 60 ± 2 (HV 700 ± 50), hardening depth 0.8 mm ± 0.2 mm, black-finished and precisely grinded.

**Accuracy:** Quality of taper < AT 3 according to DIN 7187 and DIN 2080.

**Matière:** Acier de cémentation allié. Résistance à la traction dans le noyau de min 1200 N / mm<sup>2</sup>. Cémentation à HRC 60 ± 2 (HV 700 ± 50), profondeur de cémentation 0,8 mm ± 0,2 mm, bruni et rectifié précisément.

**Précision:** Qualité du cône < AT 3 selon DIN 7187 et DIN 2080.

Внимание! Данный прайс-лист для европейского рынка.

Цены в РФ значительно отличаются от цен, указанных в данном документе!

Для получения актуальной стоимости, обращайтесь по контактам, указанным ниже.

## Inhaltsverzeichnis

Index

Table de matières



Внимание! Данный прайс-лист для европейского рынка.  
Цены в РФ значительно отличаются от цен, указанных в данном документе!  
Для получения актуальной стоимости, обращайтесь по контактам, указанным ниже.

kemmler@kemmler.su  
www.kemmler.su

**KEMMLER**



## Werkzeugaufnahmen DIN 2080

Toolholders DIN 2080

Porte-outils DIN 2080



### Spannfutter DIN 6391 für Spannzangen DIN 6388 (ISO 10897) System OZ

Collet chucks DIN 6391 for collets DIN 6388 (ISO 10897) OZ-system

Mandrins à pinces DIN 6391

pour pinces DIN 6388

(ISO 10897) système OZ

DIN 2080

$\nearrow \leq 0,003$

G6,3  
15.000 min<sup>-1</sup>

CAD

Bestell-Nr. Order no. / Réf.	Abmessung Size / Dimension	Euro
301.01.16	SK 30 - 2 / 16 - 50 OZ 16	59,00
401.01.16	SK 40 - 2 / 16 - 55 OZ 16	59,00
401.01.25	SK 40 - 2 / 25 - 66 OZ 25	60,00
401.01.32	SK 40 - 3 / 32 - 95 OZ 32	63,00
501.01.25	SK 50 - 2 / 25 - 71 OZ 25	83,00
501.01.32	SK 50 - 3 / 32 - 73 OZ 32	88,00



### Spannfutter für Spannzangen DIN 6499 (ISO 15488) System ER

Collet chucks for collets DIN 6499

(ISO 15488) ER-system

Mandrins à pinces pour pinces

DIN 6499 (ISO 15488) système ER

DIN 2080

$\nearrow \leq 0,003$

G6,3  
15.000 min<sup>-1</sup>

CAD

Bestell-Nr. Order no. / Réf.	Abmessung Size / Dimension	Euro
301.02.16	SK 30 - 2 / 16 - 50 ER 25	48,00
301.02.20	SK 30 - 2 / 20 - 50 ER 32	50,00
401.02.16	SK 40 - 2 / 16 - 50 ER 25	48,00
401.02.20	SK 40 - 2 / 20 - 50 ER 32	50,00
401.02.26	SK 40 - 3 / 26 - 80 ER 40	53,00
501.02.20	SK 50 - 2 / 20 - 63 ER 32	77,00
501.02.26	SK 50 - 3 / 26 - 63 ER 40	77,00



### Fräseraufnahmen DIN 6359 für Zylinderschäfte DIN 1835-B

End mill holders DIN 6359

for end mills DIN 1835-B

Porte-fraises DIN 6359 pour queues

cylindriques DIN 1835-B

DIN 2080

$\nearrow \leq 0,003$

G6,3  
15.000 min<sup>-1</sup>

CAD

Bestell-Nr. Order no. / Référence	Abmessung Size / Dimension	Euro
301.04.06	SK 30 - 06 - 40	39,00
301.04.08	SK 30 - 08 - 40	36,00
301.04.10	SK 30 - 10 - 40	36,00
301.04.12	SK 30 - 12 - 40	36,00
301.04.14	SK 30 - 14 - 40	36,00
301.04.16	SK 30 - 16 - 50	36,00
301.04.18	SK 30 - 18 - 50	36,00
301.04.20	SK 30 - 20 - 63	36,00
401.04.06	SK 40 - 06 - 50	39,00
401.04.08	SK 40 - 08 - 50	36,00
401.04.10	SK 40 - 10 - 50	36,00
401.04.12	SK 40 - 12 - 50	36,00
401.04.14	SK 40 - 14 - 50	36,00
401.04.16	SK 40 - 16 - 63	36,00
401.04.18	SK 40 - 18 - 63	36,00
401.04.20	SK 40 - 20 - 63	36,00
401.04.25	SK 40 - 25 - 80	41,00
401.04.32	SK 40 - 32 - 80	46,00
401.04.40	SK 40 - 40 - 90	56,00
501.04.06	SK 50 - 06 - 63	55,00
501.04.08	SK 50 - 08 - 63	53,00
501.04.10	SK 50 - 10 - 63	53,00
501.04.12	SK 50 - 12 - 63	53,00
501.04.14	SK 50 - 14 - 63	53,00
501.04.16	SK 50 - 16 - 63	53,00
501.04.18	SK 50 - 18 - 63	53,00
501.04.20	SK 50 - 20 - 63	53,00
501.04.25	SK 50 - 25 - 80	59,00
501.04.32	SK 50 - 32 - 80	63,00
501.04.40	SK 50 - 40 - 90	69,00



Внимание! Данный прайс-лист для европейского рынка.

Цены в РФ значительно отличаются от цен, указанных в данном документе!

Для получения актуальной стоимости, обращайтесь по контактам, указанным ниже.

## Werkzeugaufnahmen DIN 2080

Toolholders DIN 2080

Porte-outils DIN 2080



### Zwischenhülsen für MK mit Austreibblappen DIN 6383

Adaptor sleeves for MT with tang DIN 6383  
Douilles de réduction pour CM à tenon DIN 6383

DIN 2080

$\nearrow \leq 0,005$

G6,3  
15.000 min<sup>-1</sup>

CAD

Bestell-Nr. Order no. / Référence	Abmessung Size / Dimension	Euro
301.07.01	SK 30 - 1 - 50	36,00
301.07.02	SK 30 - 2 - 50	36,00
301.07.03	SK 30 - 3 - 75	36,00
401.07.01	SK 40 - 1 - 50	36,00
401.07.02	SK 40 - 2 - 50	36,00
401.07.03	SK 40 - 3 - 65	36,00
401.07.04	SK 40 - 4 - 95	40,00
501.07.01	SK 50 - 1 - 45	51,00
501.07.02	SK 50 - 2 - 60	51,00
501.07.03	SK 50 - 3 - 65	51,00
501.07.04	SK 50 - 4 - 70	51,00
501.07.05	SK 50 - 5 - 105	56,00



### Kombi-Aufsteckfräserdorne DIN 6358

Combi shell mill holders DIN 6358  
Porte-fraises à double usage DIN 6358

DIN 2080

$\nearrow \leq 0,005$

G6,3  
15.000 min<sup>-1</sup>

CAD

Bestell-Nr. Order no. / Référence	Abmessung Size / Dimension	Euro
301.10.16	SK 30 - 16 - 35	46,00
301.10.22	SK 30 - 22 - 35	47,00
301.10.27	SK 30 - 27 - 35	47,00
301.10.32	SK 30 - 32 - 50	51,00
401.10.16	SK 40 - 16 - 52	46,00
401.10.22	SK 40 - 22 - 52	47,00
401.10.27	SK 40 - 27 - 52	47,00
401.10.32	SK 40 - 32 - 52	51,00
401.10.40	SK 40 - 40 - 52	58,00
501.10.16	SK 50 - 16 - 55	62,00
501.10.22	SK 50 - 22 - 55	62,00
501.10.27	SK 50 - 27 - 55	63,00
501.10.32	SK 50 - 32 - 55	66,00
501.10.40	SK 50 - 40 - 55	72,00



### Zwischenhülsen für MK mit Anzugsgewinde DIN 6364

Adaptor sleeves for MT with drawbar thread DIN 6364  
Douilles de réduction pour CM avec filetage DIN 6364

DIN 2080

$\nearrow \leq 0,005$

G6,3  
15.000 min<sup>-1</sup>

CAD

Bestell-Nr. Order no. / Référence	Abmessung Size / Dimension	Euro
401.08.01	SK 40 - 1 - 50	59,00
401.08.02	SK 40 - 2 - 50	59,00
401.08.03	SK 40 - 3 - 65	59,00
401.08.04	SK 40 - 4 - 95	63,00
401.08.04A*	SK 40 - 4 - 110	70,00
501.08.01	SK 50 - 1 - 60	77,00
501.08.02	SK 50 - 2 - 60	77,00
501.08.03	SK 50 - 3 - 65	77,00
501.08.04	SK 50 - 4 - 65	83,00
501.08.04A*	SK 50 - 4 - 80	90,00
501.08.05	SK 50 - 5 - 120	86,00
501.08.05A*	SK 50 - 5 - 138	97,00

\* Mit Mitnehmerausfräsung nach DIN 2201

\* With driving facilities according to DIN 2201

\* Avec fraisage d'entraînement selon DIN 2201



### Quernut-Aufsteckfräserdorne DIN 6357 mit vergrößerter Anlagefläche

Shell mill holders DIN 6357 with enlarged contact face  
Porte-fraises à trou lisse DIN 6357 avec face de contact élargie

DIN 2080

$\nearrow \leq 0,005$

G6,3  
15.000 min<sup>-1</sup>

CAD

Bestell-Nr. Order no. / Référence	Abmessung Size / Dimension	Euro
401.11.16	SK 40 - 16 - 30	50,00
401.11.22	SK 40 - 22 - 30	50,00
401.11.27	SK 40 - 27 - 30	51,00
401.11.32	SK 40 - 32 - 30	54,00
401.11.40	SK 40 - 40 - 30	66,00
501.11.22	SK 50 - 22 - 35	66,00
501.11.27	SK 50 - 27 - 35	66,00
501.11.32	SK 50 - 32 - 40	70,00
501.11.40	SK 50 - 40 - 33	80,00
501.11.60	SK 50 - 60 - 55	122,00



Внимание! Данный прайс-лист для европейского рынка.  
Цены в РФ значительно отличаются от цен, указанных в данном документе!  
Для получения актуальной стоимости, обращайтесь по контактам, указанным ниже.





## Werkzeugaufnahmen DIN 2080

Toolholders DIN 2080

Porte-outils DIN 2080



### Bohrfutteraufnahmen DIN 238

Drill chuck adaptors DIN 238

Arbres pour mandrins de perçage  
DIN 238

DIN 2080

$\uparrow \leq 0,005$

G6,3  
15.000 min<sup>-1</sup>

CAD

Bestell-Nr. Order no. / Référence	Abmessung Size / Dimension	Euro
301.14.12	SK 30 - B12	39,00
301.14.16	SK 30 - B16	39,00
401.14.12	SK 40 - B12	39,00
401.14.16	SK 40 - B16	39,00
401.14.18	SK 40 - B18	39,00
501.14.16	SK 50 - B16	50,00
501.14.18	SK 50 - B18	50,00



### Zwischenhülsen für SK-Aufnahmen

Adaptor sleeves for ISO-toolholders  
Douilles de réduction pour  
porte-outils ISO/SA

DIN 2080

$\uparrow \leq 0,005$

G6,3  
15.000 min<sup>-1</sup>

CAD

Bestell-Nr. Order no. / Référence	Abmessung Size / Dimension	Euro
401.09.30	SK 40 - SK 30 - 50	98,00
401.09.40	SK 40 - SK 40 - 100	98,00
501.09.40	SK 50 - SK 40 - 50	123,00
501.09.50	SK 50 - SK 50 - 125	141,00



### CNC-Bohrfutter für Rechts- und Linkslauf

CNC-Drill chucks for clockwise  
and counter clockwise rotation  
Mandrins de perçage CNC  
pour rotation gauche-droite

DIN 2080

$\uparrow \leq 0,03$

G6,3  
15.000 min<sup>-1</sup>

CAD

Bestell-Nr. Order no. / Référence	Abmessung Size / Dimension	Euro
301.15.08	SK 30 - 0,5 / 8 - 58	328,00
301.15.13	SK 30 - 1,0 / 13 - 79	273,00
301.15.16	SK 30 - 2,5 / 16 - 84	294,00
401.15.08	SK 40 - 0,5 / 8 - 63	246,00
401.15.13	SK 40 - 1,0 / 13 - 83	218,00
401.15.16	SK 40 - 2,5 / 16 - 88	235,00
501.15.13	SK 50 - 1,0 / 13 - 108	257,00
501.15.16	SK 50 - 2,5 / 16 - 113	273,00

### Gewindeschneid-Schnellwechselfutter mit Längenausgleich auf Druck und Zug

Quick change tapping chucks  
with length compensation  
on compression and expansion  
Mandrins de taraudage à  
changement rapide avec  
compensation longitudinale à  
la compression et traction



DIN 2080

CAD

Bestell-Nr. Order no. / Référence	Abmessung Size / Dimension	Euro
301.16.12	SK30 - M3 / M14 Gr. 1	191,00
301.16.20	SK30 - M5 / M22 Gr. 2	201,00
401.16.12	SK40 - M3 / M14 Gr. 1	191,00
401.16.20	SK40 - M5 / M22 Gr. 2	201,00
401.16.36	SK40 - M14 / M36 Gr. 3	302,00
501.16.12	SK50 - M3 / M14 Gr. 1	235,00
501.16.20	SK50 - M5 / M22 Gr. 2	246,00
501.16.36	SK50 - M14 / M36 Gr. 3	346,00



Внимание! Данный прайс-лист для европейского рынка.

Цены в РФ значительно отличаются от цен, указанных в данном документе!

Для получения актуальной стоимости, обращайтесь по контактам, указанным ниже.

kemmler@kemmler.su  
www.kemmler.su

## Werkzeugaufnahmen DIN 2080

Toolholders DIN 2080

Porte-outils DIN 2080



### Bohrstangenrohlinge

Boring bar blanks

Barres d'alésage

DIN 2080

CAD

Bestell-Nr. Order no. / Référence	Abmessung Size / Dimension	Euro
401.17.63	SK 40 - 63 - 250	110,00
501.17.97	SK 50 - 97 - 315	179,00



### Gewuchtete Ausführung

Balanced type

Type équilibré

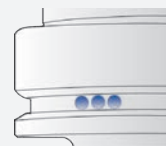

Bestell-Nr. Order no. / Référence	Abmessung Size / Dimension	Euro
--------------------------------------	-------------------------------	------

#### Wuchten auf G 2,5 von vorgewuchteten Kemmler-Werkzeugen

Balancing at G 2.5 of pre-balanced Kemmler-tools

Équilibrage sur G 2,5 d'outils Kemmler pré-équilibrés

W25	<b>Ohne Wuchtprotokoll</b> Without balancing report Sans protocole d'équilibrage	15,00
-----	----------------------------------------------------------------------------------------	-------

W25.2	<b>Mit Wuchtprotokoll</b> With balancing report Avec protocole d'équilibrage	19,00
-------	------------------------------------------------------------------------------------	-------

#### Wuchten von nicht vorgewuchteten Werkzeugen

Balancing of unbalanced tools

Équilibrage d'outils non-équilibrés

W25.1	<b>Ohne Wuchtprotokoll</b> Without balancing report Sans protocole d'équilibrage	28,00
-------	----------------------------------------------------------------------------------------	-------

Внимание! Данный прайс-лист для европейского рынка.  
Цены в РФ значительно отличаются от цен, указанных в данном документе!  
Для получения актуальной стоимости, обращайтесь по контактам, указанным ниже.

**KEMMLER**

**51**



## Werkzeugaufnahmen DIN 69893 / ISO 12164-1 (HSK)

Toolholders DIN 69893 / ISO 12164-1 (HSK)

Porte-outils DIN 69893 / ISO 12164-1 (HSK)

Vorgewuchtet

Pre-balanced

Pré-équilibré

G 6,3 15.000 min<sup>-1</sup>

G 2,5 Feinwuchten gegen Aufpreis

G 2,5 Fine balancing at extra charge

G 2,5 Equilibrage fin contre un supplément

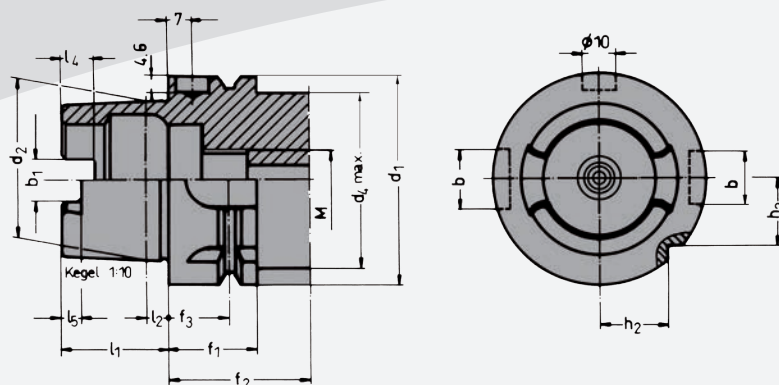

d <sub>1</sub>	d <sub>2</sub>	d <sub>4</sub>	l <sub>1</sub>	l <sub>2</sub>	l <sub>4</sub>	l <sub>5</sub>	M	f <sub>1</sub>	f <sub>2</sub>	f <sub>3</sub>	b <sub>1</sub>	b <sub>2</sub>	b <sub>3</sub>
32	24	26	16	3,2	5,0	3,0	M10 × 1	20	35	16	7,05	7	9
40	30	34	20	4,0	6,0	3,5	M12 × 1	20	35	16	8,05	9	11
50	38	42	25	5,0	7,5	4,5	M16 × 1	26	42	18	10,54	12	14
63	48	53	32	6,3	10,0	6,0	M18 × 1	26	42	18	12,54	16	18
80	60	67	40	8,0	12,0	8,0	M20 × 1,5	26	42	18	16,04	18	20
100	75	85	50	10,0	15,0	10,0	M24 × 1,5	29	45	20	20,02	22	20

**Werkstoff:** Legierter Einsatzstahl mit einer Zugfestigkeit im Kern von min. 1200 N / mm<sup>2</sup>. Einsatzgehärtet HRC 60 ± 2 (HV 700 ± 50), Härtetiefe 0,8 mm ± 0,2 mm, brüniert und präzisionsgeschliffen.

**Material:** Alloyed case-hardened steel, tensile core strength of min. 1200 N / mm<sup>2</sup>. Case hardened HRC 60 ± 2 (HV 700 ± 50), hardening depth 0.8 mm ± 0.2 mm, black-finished and precisely grinded.

**Matière:** Acier de cémentation allié. Résistance à la traction dans le noyau de min 1200 N / mm<sup>2</sup>. Cémentation à HRC 60 ± 2 (HV 700 ± 50), profondeur de cémentation 0,8 mm ± 0,2 mm, bruni et rectifié précisément.



Внимание! Данный прайс-лист для европейского рынка.

Цены в РФ значительно отличаются от цен, указанных в данном документе!

Для получения актуальной стоимости, обращайтесь по контактам, указанным ниже.

# Inhaltsverzeichnis

Index

Table de matières



Внимание! Данный прайс-лист для европейского рынка.  
Цены в РФ значительно отличаются от цен, указанных в данном документе!  
Для получения актуальной стоимости, обращайтесь по контактам, указанным ниже.



## Werkzeugaufnahmen DIN 69893 / ISO 12164-1 (HSK)

Toolholders DIN 69893 / ISO 12164-1 (HSK)

Porte-outils DIN 69893 / ISO 12164-1 (HSK)



### Spannfutter für Spannzangen DIN 6388 (ISO 10897) System OZ

Collet chucks for collets DIN 6388  
(ISO 10897) OZ-system

Mandrins à pinces pour pinces  
DIN 6388 (ISO 10897) système OZ

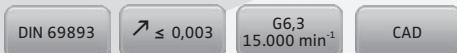

Bestell-Nr. Order no. / Réf.	Abmessung Size / Dimension	Euro
A63.01.16	HSK 63 - 2 / 16 - 100 OZ 16	105,00
A63.01.25	HSK 63 - 2 / 25 - 100 OZ 25	105,00
A63.01.32	HSK 63 - 3 / 32 - 120 OZ 32	112,00
A100.01.16	HSK 100-2 / 16 - 110 OZ 16	134,00
A100.01.25	HSK 100-2 / 25 - 120 OZ 25	134,00
A100.01.32	HSK 100-3 / 32 - 130 OZ 32	143,00



### Spannfutter für Spannzangen System KPS

Collet chucks for collets  
KPS-system

Mandrins à pinces pour pinces  
système KPS



Bestell-Nr. Order no. / Réf.	Abmessung Size / Dimension	Euro
A63.03.10	HSK 63 - 1 / 10 - 100 KPS 10	140,00
A63.03.16	HSK 63 - 4 / 16 - 120 KPS 16	147,00



### Spannfutter für Spannzangen DIN 6499 (ISO 15488) System ER

Collet chucks for collets DIN 6499  
(ISO 15488) ER-system

Mandrins à pinces pour pinces  
DIN 6499 (ISO 15488) système ER



Bestell-Nr. Order no. / Réf.	Abmessung Size / Dimension	Euro
A63.02.10.0	HSK 63 - 1 / 10 - 75 ER 16	92,00
A63.02.13.0	HSK 63 - 2 / 13 - 75 ER 20	92,00
A63.02.16.0	HSK 63 - 2 / 16 - 75 ER 25	92,00
A63.02.20.0	HSK 63 - 2 / 20 - 75 ER 32	96,00
A63.02.26.0	HSK 63 - 3 / 26 - 85 ER 40	102,00
A63.02.10	HSK 63 - 1 / 10 - 100 ER 16	92,00
A63.02.13	HSK 63 - 2 / 13 - 100 ER 20	92,00
A63.02.16	HSK 63 - 2 / 16 - 100 ER 25	92,00
A63.02.20	HSK 63 - 2 / 20 - 100 ER 32	96,00
A63.02.26	HSK 63 - 3 / 26 - 120 ER 40	102,00
A63.02.10.1	HSK 63 - 1 / 10 - 160 ER 16	136,00
A63.02.13.1	HSK 63 - 2 / 13 - 160 ER 20	136,00
A63.02.16.1	HSK 63 - 2 / 16 - 160 ER 25	136,00
A63.02.20.1	HSK 63 - 2 / 20 - 160 ER 32	140,00
A63.02.26.1	HSK 63 - 3 / 26 - 160 ER 40	151,00
A63.02.10.3	HSK 63 - 1 / 10 - 200 ER 16	179,00
A63.02.13.3	HSK 63 - 2 / 13 - 200 ER 20	179,00
A63.02.16.3	HSK 63 - 2 / 16 - 200 ER 25	179,00
A63.02.20.3	HSK 63 - 2 / 20 - 200 ER 32	179,00
A63.02.26.3	HSK 63 - 3 / 26 - 200 ER 40	189,00



Внимание! Данный прайс-лист для европейского рынка.

Цены в РФ значительно отличаются от цен, указанных в данном документе!

Для получения актуальной стоимости, обращайтесь по контактам, указанным ниже.

kemmler@kemmler.su  
www.kemmler.su



## Werkzeugaufnahmen DIN 69893 / ISO 12164-1 (HSK)

Toolholders DIN 69893 / ISO 12164-1 (HSK)

Porte-outils DIN 69893 / ISO 12164-1 (HSK)



### Spannfutter für Spannzangen DIN 6499 (ISO 15488) System ER

Collet chucks for collets DIN 6499  
(ISO 15488) ER-system  
Mandrins à pinces pour pinces  
DIN 6499 (ISO 15488) système ER

DIN 69893

$\nearrow \leq 0,003$

G6,3  
15.000 min<sup>-1</sup>

CAD

Bestell-Nr. Order no. / Réf.	Abmessung Size / Dimension	Euro
A100.02.16	HSK 100 - 2 / 16 - 100 ER 25	117,00
A100.02.20	HSK 100 - 2 / 20 - 100 ER 32	117,00
A100.02.26	HSK 100 - 3 / 26 - 120 ER 40	121,00
A100.02.16.2	HSK 100 - 2 / 16 - 160 ER 25	141,00
A100.02.20.2	HSK 100 - 2 / 20 - 160 ER 32	141,00
A100.02.26.2	HSK 100 - 3 / 26 - 160 ER 40	141,00



### Spannfutter für Spannzangen DIN 6499 (ISO 15488) System ER

Collet chucks for collets DIN 6499  
(ISO 15488) ER-system  
Mandrins à pinces pour pinces  
DIN 6499 (ISO 15488) système ER

DIN 69893

$\nearrow \leq 0,003$

G6,3  
15.000 min<sup>-1</sup>

CAD

Bestell-Nr. Order no. / Réf.	Abmessung Size / Dimension	Euro
A63.02.07.1	HSK 63 - 1 / 7 - 100 ER 11	147,00
A63.02.07.2	HSK 63 - 1 / 7 - 160 ER 11	168,00
A63.02.07.10.1	HSK 63 - 1 / 10 - 100 ER 16	147,00
A63.02.07.10.2	HSK 63 - 1 / 10 - 160 ER 16	168,00

Mit Minimutter | With mini nut | Avec écrous-mini



### Hochleistungs-Kraftspannfutter System HKS

High Performance Milling Chuck  
HKS-system  
Mandrin de serrage  
à haute performance système HKS

DIN 69893

$\nearrow \leq 0,003$

G6,3  
15.000 min<sup>-1</sup>

CAD

Bestell-Nr. Order no. / Référence	Abmessung Size / Dimension	Euro
A63.64.20	HSK 63 - 20 - 95	305,00
A63.64.32	HSK 63 - 32 - 110	315,00
A100.64.20	HSK 100 - 20 - 105	378,00
A100.64.32	HSK 100 - 32 - 105	399,00



### Gewuchtete Ausführung

Balanced type  
Type équilibré



Bestell-Nr. Order no. / Référence	Abmessung Size / Dimension	Euro
<b>Wuchten auf G 2,5 von vorgewuchteten Kemmler-Werkzeugen</b>		
Balancing at G 2.5 of pre-balanced Kemmler-tools Équilibrage sur G 2,5 d'outils Kemmler pré-équilibrés		

W25 **Ohne Wuchtprotokoll** 15,00  
Without balancing report  
Sans protocole d'équilibrage

W25.2 **Mit Wuchtprotokoll** 19,00  
With balancing report  
Avec protocole d'équilibrage

### Wuchten von nicht vorgewuchteten Werkzeugen

Balancing of unbalanced tools  
Équilibrage d'outils non-équilibrés

W25.1 **Ohne Wuchtprotokoll** 28,00  
Without balancing report  
Sans protocole d'équilibrage

Внимание! Данный прайс-лист для европейского рынка.  
Цены в РФ значительно отличаются от цен, указанных в данном документе!  
Для получения актуальной стоимости, обращайтесь по контактам, указанным ниже.



## Werkzeugaufnahmen DIN 69893 / ISO 12164-1 (HSK)

Toolholders DIN 69893 / ISO 12164-1 (HSK)

Porte-outils DIN 69893 / ISO 12164-1 (HSK)



### Fräseraufnahmen DIN 6359 für Zylinderschäfte DIN 1835-B

End mill holders DIN 6359  
for end mills DIN 1835-B  
Porte-fraises DIN 6359 pour queues  
cylindriques DIN 1835-B

DIN 69893

$\nearrow \leq 0,003$

G6,3  
15.000 min<sup>-1</sup>

CAD

Bestell-Nr. Order no. / Référence	Abmessung Size / Dimension	Euro
A63.04.06	HSK 63 - 06 - 65	99,00
A63.04.08	HSK 63 - 08 - 65	92,00
A63.04.10	HSK 63 - 10 - 65	92,00
A63.04.12	HSK 63 - 12 - 80	92,00
A63.04.14	HSK 63 - 14 - 80	92,00
A63.04.16	HSK 63 - 16 - 80	92,00
A63.04.18	HSK 63 - 18 - 80	92,00
A63.04.20	HSK 63 - 20 - 80	92,00
A63.04.25	HSK 63 - 25 - 110	97,00
A63.04.32	HSK 63 - 32 - 110	103,00
A63.04.40	HSK 63 - 40 - 125	130,00
A63.04.06.1	HSK 63 - 06 - 100	115,00
A63.04.08.1	HSK 63 - 08 - 100	111,00
A63.04.10.1	HSK 63 - 10 - 100	111,00
A63.04.12.1	HSK 63 - 12 - 100	111,00
A63.04.14.1	HSK 63 - 14 - 100	111,00
A63.04.16.1	HSK 63 - 16 - 100	111,00
A63.04.18.1	HSK 63 - 18 - 100	111,00
A63.04.20.1	HSK 63 - 20 - 100	111,00
A63.04.06.2	HSK 63 - 06 - 160	130,00
A63.04.08.2	HSK 63 - 08 - 160	130,00
A63.04.10.2	HSK 63 - 10 - 160	130,00
A63.04.12.2	HSK 63 - 12 - 160	130,00
A63.04.14.2	HSK 63 - 14 - 160	130,00
A63.04.16.2	HSK 63 - 16 - 160	130,00
A63.04.18.2	HSK 63 - 18 - 160	130,00
A63.04.20.2	HSK 63 - 20 - 160	130,00



### Fräseraufnahmen DIN 6359 für Zylinderschäfte DIN 1835-B

End mill holders DIN 6359  
for end mills DIN 1835-B  
Porte-fraises DIN 6359 pour queues  
cylindriques DIN 1835-B

DIN 69893

$\nearrow \leq 0,003$

G6,3  
15.000 min<sup>-1</sup>

CAD

Bestell-Nr. Order no. / Référence	Abmessung Size / Dimension	Euro
A100.04.06	HSK 100 - 06 - 80	125,00
A100.04.08	HSK 100 - 08 - 80	119,00
A100.04.10	HSK 100 - 10 - 80	119,00
A100.04.12	HSK 100 - 12 - 80	119,00
A100.04.14	HSK 100 - 14 - 80	119,00
A100.04.16	HSK 100 - 16 - 100	119,00
A100.04.18	HSK 100 - 18 - 100	119,00
A100.04.20	HSK 100 - 20 - 100	119,00
A100.04.25	HSK 100 - 25 - 100	123,00
A100.04.32	HSK 100 - 32 - 100	133,00
A100.04.40	HSK 100 - 40 - 105	157,00
A100.04.06.2	HSK 100 - 06 - 160	237,00
A100.04.08.2	HSK 100 - 08 - 160	229,00
A100.04.10.2	HSK 100 - 10 - 160	229,00
A100.04.12.2	HSK 100 - 12 - 160	229,00
A100.04.14.2	HSK 100 - 14 - 160	229,00
A100.04.16.2	HSK 100 - 16 - 160	229,00
A100.04.18.2	HSK 100 - 18 - 160	229,00
A100.04.20.2	HSK 100 - 20 - 160	229,00
A100.04.25.2	HSK 100 - 25 - 160	237,00
A100.04.32.2	HSK 100 - 32 - 160	249,00
A100.04.40.2	HSK 100 - 40 - 160	261,00



Внимание! Данный прайс-лист для европейского рынка.

Цены в РФ значительно отличаются от цен, указанных в данном документе!

Для получения актуальной стоимости, обращайтесь по контактам, указанным ниже.

## Werkzeugaufnahmen DIN 69893 / ISO 12164-1 (HSK)

Toolholders DIN 69893 / ISO 12164-1 (HSK)

Porte-outils DIN 69893 / ISO 12164-1 (HSK)

### Fräseraufnahmen DIN 6359 mit Kühlkanälen für Zylinderschäfte DIN 1835-B

End mill holders DIN 6359 with coolant  
channels for end mills DIN 1835-B

Porte-fraises DIN 6359 avec canaux  
d'arrosage pour queues cylindriques  
DIN 1835-B



DIN 69893

$\uparrow \leq 0,003$

G6,3  
15.000 min<sup>-1</sup>

CAD

Bestell-Nr. Order no. / Référence	Abmessung Size / Dimension	Euro
A63.04.06.K	HSK 63 - 06 - 65	111,00
A63.04.08.K	HSK 63 - 08 - 65	104,00
A63.04.10.K	HSK 63 - 10 - 65	104,00
A63.04.12.K	HSK 63 - 12 - 80	104,00
A63.04.14.K	HSK 63 - 14 - 80	104,00
A63.04.16.K	HSK 63 - 16 - 80	104,00
A63.04.18.K	HSK 63 - 18 - 80	104,00
A63.04.20.K	HSK 63 - 20 - 80	104,00
A63.04.25.K	HSK 63 - 25 - 110	123,00
A63.04.32.K	HSK 63 - 32 - 110	130,00
A63.04.40.K	HSK 63 - 40 - 125	141,00
A63.04.06.1.K	HSK 63 - 06 - 100	119,00
A63.04.08.1.K	HSK 63 - 08 - 100	119,00
A63.04.10.1.K	HSK 63 - 10 - 100	119,00
A63.04.12.1.K	HSK 63 - 12 - 100	119,00
A63.04.14.1.K	HSK 63 - 14 - 100	119,00
A63.04.16.1.K	HSK 63 - 16 - 100	119,00
A63.04.18.1.K	HSK 63 - 18 - 100	119,00
A63.04.20.1.K	HSK 63 - 20 - 100	119,00
A100.04.06.K	HSK 100 - 06 - 80	147,00
A100.04.08.K	HSK 100 - 08 - 80	141,00
A100.04.10.K	HSK 100 - 10 - 80	141,00
A100.04.12.K	HSK 100 - 12 - 80	141,00
A100.04.14.K	HSK 100 - 14 - 80	141,00
A100.04.16.K	HSK 100 - 16 - 100	141,00
A100.04.18.K	HSK 100 - 18 - 100	141,00
A100.04.20.K	HSK 100 - 20 - 100	141,00
A100.04.25.K	HSK 100 - 25 - 100	163,00
A100.04.32.K	HSK 100 - 32 - 100	173,00
A100.04.40.K	HSK 100 - 40 - 105	183,00

### Fräseraufnahmen DIN 6359 für Zylinderschäfte DIN 1835-E Whistle Notch

End mill holders DIN 6359 for end  
mills DIN 1835-E Whistle Notch

Porte-fraises DIN 6359 pour  
queues cylindriques DIN 1835-E  
Whistle Notch



DIN 69893

$\uparrow \leq 0,003$

G6,3  
15.000 min<sup>-1</sup>

CAD

Bestell-Nr. Order no. / Référence	Abmessung Size / Dimension	Euro
A63.05.06	HSK 63 - 06 - 80	101,00
A63.05.08	HSK 63 - 08 - 80	96,00
A63.05.10	HSK 63 - 10 - 80	96,00
A63.05.12	HSK 63 - 12 - 90	96,00
A63.05.14	HSK 63 - 14 - 90	96,00
A63.05.16	HSK 63 - 16 - 100	96,00
A63.05.18	HSK 63 - 18 - 100	96,00
A63.05.20	HSK 63 - 20 - 100	96,00
A63.05.25	HSK 63 - 25 - 110	112,00
A63.05.32	HSK 63 - 32 - 110	119,00
A100.05.06	HSK 100 - 06 - 90	138,00
A100.05.08	HSK 100 - 08 - 90	133,00
A100.05.10	HSK 100 - 10 - 90	133,00
A100.05.12	HSK 100 - 12 - 100	133,00
A100.05.14	HSK 100 - 14 - 100	133,00
A100.05.16	HSK 100 - 16 - 100	133,00
A100.05.18	HSK 100 - 18 - 100	133,00
A100.05.20	HSK 100 - 20 - 110	133,00
A100.05.25	HSK 100 - 25 - 120	155,00
A100.05.32	HSK 100 - 32 - 120	163,00
A100.05.40	HSK 100 - 40 - 120	175,00



### Gewuchtete Ausführung

Balanced type

Type équilibré

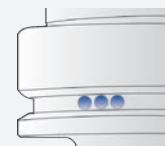

Bestell-Nr. Order no. / Référence	Abmessung Size / Dimension	Euro
--------------------------------------	-------------------------------	------

### Wuchten auf G 2,5 von vorgewuchteten Kemmler-Werkzeugen

Balancing at G 2.5 of pre-balanced Kemmler-tools

Équilibrage sur G 2,5 d'outils Kemmler pré-équilibrés

W25	<b>Ohne Wuchtprotokoll</b> Without balancing report Sans protocole d'équilibrage	15,00
-----	----------------------------------------------------------------------------------------	-------

W25.2	<b>Mit Wuchtprotokoll</b> With balancing report Avec protocole d'équilibrage	19,00
-------	------------------------------------------------------------------------------------	-------

### Wuchten von nicht vorgewuchteten Werkzeugen

Balancing of unbalanced tools

Équilibrage d'outils non-équilibrés

W25.1	<b>Ohne Wuchtprotokoll</b> Without balancing report Sans protocole d'équilibrage	28,00
-------	----------------------------------------------------------------------------------------	-------

Внимание! Данный прайс-лист для европейского рынка.

Цены в РФ значительно отличаются от цен, указанных в данном документе!

Для получения актуальной стоимости, обращайтесь по контактам, указанным ниже.

**KEMMLER**

57



## Werkzeugaufnahmen DIN 69893 / ISO 12164-1 (HSK)

Toolholders DIN 69893 / ISO 12164-1 (HSK)

Porte-outils DIN 69893 / ISO 12164-1 (HSK)



### Fräsaufnahme für Einschraubfräser

Milling arbors for screw-  
in cutters

Porte-fraises pour  
fraises à queue filetée

DIN 69893

$\uparrow \leq 0,003$

G6.3  
15.000 min<sup>-1</sup>

CAD

Bestell-Nr.	Abmessung	Euro
Order no. / Référence	Size / Dimension	
A63.06.06	HSK 63 - M6 - 51	160,00
A63.06.08	HSK 63 - M8 - 51	160,00
A63.06.08.1	HSK 63 - M8 - 76	174,00
A63.06.08.2	HSK 63 - M8 - 101	189,00
A63.06.10	HSK 63 - M10 - 51	160,00
A63.06.10.1	HSK 63 - M10 - 76	179,00
A63.06.10.3	HSK 63 - M10 - 126	217,00
A63.06.10.5	HSK 63 - M10 - 176	259,00
A63.06.12	HSK 63 - M12 - 51	160,00
A63.06.12.1	HSK 63 - M12 - 76	179,00
A63.06.12.2	HSK 63 - M12 - 101	197,00
A63.06.12.3	HSK 63 - M12 - 126	217,00
A63.06.12.5	HSK 63 - M12 - 176	259,00
A63.06.16	HSK 63 - M16 - 51	160,00
A63.06.16.1	HSK 63 - M16 - 76	179,00
A63.06.16.2	HSK 63 - M16 - 101	197,00
A63.06.16.3	HSK 63 - M16 - 126	217,00
A63.06.16.5	HSK 63 - M16 - 176	259,00
A100.06.08.1	HSK 100 - M8 - 79	213,00
A100.06.10.1	HSK 100 - M10 - 79	213,00
A100.06.10.3	HSK 100 - M10 - 129	260,00
A100.06.10.5	HSK 100 - M10 - 179	307,00
A100.06.12.1	HSK 100 - M12 - 79	213,00
A100.06.12.3	HSK 100 - M12 - 129	260,00
A100.06.12.5	HSK 100 - M12 - 179	307,00
A100.06.16.1	HSK 100 - M16 - 79	213,00
A100.06.16.3	HSK 100 - M16 - 129	260,00
A100.06.16.5	HSK 100 - M16 - 179	307,00





## Werkzeugaufnahmen DIN 69893 / ISO 12164-1 (HSK)

Toolholders DIN 69893 / ISO 12164-1 (HSK)

Porte-outils DIN 69893 / ISO 12164-1 (HSK)



### Комби-Аufsteckфрäserдорне DIN 6358

Combi shell mill holders DIN 6358  
Porte-fraises à double usage  
DIN 6358

DIN 69893

$\uparrow \leq 0,005$

G6,3  
15.000 min<sup>-1</sup>

CAD

Bestell-Nr. Order no. / Référence	Abmessung Size / Dimension	Euro
A63.10.16	HSK 63 - 16 - 60	105,00
A63.10.22	HSK 63 - 22 - 60	105,00
A63.10.27	HSK 63 - 27 - 60	109,00
A63.10.32	HSK 63 - 32 - 60	116,00
A63.10.40	HSK 63 - 40 - 70	125,00
A63.10.16.1	HSK 63 - 16 - 100	125,00
A63.10.22.1	HSK 63 - 22 - 100	125,00
A63.10.27.1	HSK 63 - 27 - 100	129,00
A63.10.32.1	HSK 63 - 32 - 100	138,00
A100.10.16	HSK 100 - 16 - 60	134,00
A100.10.22	HSK 100 - 22 - 60	134,00
A100.10.27	HSK 100 - 27 - 60	137,00
A100.10.32	HSK 100 - 32 - 60	145,00
A100.10.40	HSK 100 - 40 - 70	158,00



### Quernut-Aufsteckфрäserдорне DIN 6357 mit vergrößerter Anlagefläche und Kühlkanal- bohrungen an der Stirnseite

Shell mill holders DIN 6357 with  
enlarged contact face and coolant  
exit bores on the end face  
Porte-fraises à trou lisse DIN 6357  
avec face de contact élargie et  
conduits pour l'arrosage frontal

DIN 69893

$\uparrow \leq 0,005$

G6,3  
15.000 min<sup>-1</sup>

CAD

Bestell-Nr. Order no. / Référence	Abmessung Size / Dimension	Euro
A63.11.16	HSK 63 - 16 - 50	112,00
A63.11.22	HSK 63 - 22 - 50	112,00
A63.11.27	HSK 63 - 27 - 60	112,00
A63.11.32	HSK 63 - 32 - 60	116,00
A63.11.40	HSK 63 - 40 - 60	146,00
A63.11.16.1	HSK 63 - 16 - 100	136,00
A63.11.22.1	HSK 63 - 22 - 100	136,00
A63.11.27.1	HSK 63 - 27 - 100	136,00
A63.11.32.1	HSK 63 - 32 - 100	140,00
A63.11.40.1	HSK 63 - 40 - 100	173,00
A63.11.16.2	HSK 63 - 16 - 160	176,00
A63.11.22.2	HSK 63 - 22 - 160	176,00
A63.11.27.2	HSK 63 - 27 - 160	176,00
A63.11.32.2	HSK 63 - 32 - 160	182,00
A63.11.40.2	HSK 63 - 40 - 160	224,00
A100.11.22	HSK 100 - 22 - 50	141,00
A100.11.27	HSK 100 - 27 - 60	141,00
A100.11.32	HSK 100 - 32 - 50	145,00
A100.11.40	HSK 100 - 40 - 70	165,00
A100.11.60	HSK 100 - 60 - 70	197,00
A100.11.22.1	HSK 100 - 22 - 100	162,00
A100.11.27.1	HSK 100 - 27 - 100	162,00
A100.11.32.1	HSK 100 - 32 - 100	167,00
A100.11.40.1	HSK 100 - 40 - 100	173,00



Внимание! Данный прайс-лист для европейского рынка.  
Цены в РФ значительно отличаются от цен, указанных в данном документе!  
Для получения актуальной стоимости, обращайтесь по контактам, указанным ниже.





## Werkzeugaufnahmen DIN 69893 / ISO 12164-1 (HSK)

Toolholders DIN 69893 / ISO 12164-1 (HSK)

Porte-outils DIN 69893 / ISO 12164-1 (HSK)



### Zwischenhülsen für MK mit Austreibblappen DIN 6383

Adaptor sleeves for MT with tang DIN 6383  
Douilles de réduction pour CM à tenon DIN 6383



Bestell-Nr. Order no. / Référence	Abmessung Size / Dimension	Euro
A63.07.01	HSK 63 - 1 - 100	84,00
A63.07.02	HSK 63 - 2 - 120	86,00
A63.07.03	HSK 63 - 3 - 140	87,00
A63.07.04	HSK 63 - 4 - 160	90,00
A100.07.01	HSK 100 - 1 - 110	119,00
A100.07.02	HSK 100 - 2 - 120	121,00
A100.07.03	HSK 100 - 3 - 150	123,00
A100.07.04	HSK 100 - 4 - 170	130,00
A100.07.05	HSK 100 - 5 - 200	138,00



87



66

### Gewindeschneid-Schnellwechselfutter mit Längenausgleich auf Druck und Zug

Quick change tapping chucks **with** length compensation on compression and expansion  
Mandrins de taraudage à changement rapide **avec** compensation longitudinale à la compression et traction



Bestell-Nr. Order no. / Réf.	Abmessung Size / Dimension	Euro
A63.16.12	HSK 63 - M3 / M14 Gr. 1	326,00
A63.16.20	HSK 63 - M5 / M22 Gr. 2	357,00
A100.16.12	HSK 100 - M3 / M14 Gr. 1	446,00
A100.16.20	HSK 100 - M5 / M22 Gr. 2	491,00
A100.16.36	HSK 100 - M14 / M36 Gr. 3	580,00



116



116



117



### Zwischenhülsen für MK mit Anzugsgewinde DIN 6364

Adaptor sleeves for MT with drawbar thread DIN 6364  
Douilles de réduction pour CM avec filetage DIN 6364



Bestell-Nr. Order no. / Référence	Abmessung Size / Dimension	Euro
A63.08.01	HSK 63 - 1 - 100	95,00
A63.08.02	HSK 63 - 2 - 120	95,00
A63.08.03	HSK 63 - 3 - 140	100,00
A63.08.04	HSK 63 - 4 - 160	110,00
A100.08.01	HSK 100 - 1 - 110	135,00
A100.08.02	HSK 100 - 2 - 120	135,00
A100.08.03	HSK 100 - 3 - 150	140,00
A100.08.04	HSK 100 - 4 - 170	145,00
A100.08.05	HSK 100 - 5 - 200	153,00



66

### Gewindeschneid-Schnellwechselfutter ohne Längenausgleich auf Druck und Zug

Quick change tapping chucks **without** length compensation on compression and expansion  
Mandrins de taraudage à changement rapide **sans** compensation longitudinale à la compression et traction

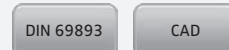

Bestell-Nr. Order no. / Réf.	Abmessung Size / Dimension	Euro
A63.16.12.1	HSK 63 - M3 / M14 Gr. 1	195,00
A63.16.20.1	HSK 63 - M5 / M22 Gr. 2	205,00
A100.16.12.1	HSK 100 - M3 / M14 Gr. 1	296,00
A100.16.20.1	HSK 100 - M5 / M22 Gr. 2	363,00
A100.16.36.1	HSK 100 - M14 / M36 Gr. 3	450,00



116



116



117

Внимание! Данный прайс-лист для европейского рынка.

Цены в РФ значительно отличаются от цен, указанных в данном документе!

Для получения актуальной стоимости, обращайтесь по контактам, указанным ниже.

## Werkzeugaufnahmen DIN 69893 / ISO 12164-1 (HSK)

Toolholders DIN 69893 / ISO 12164-1 (HSK)

Porte-outils DIN 69893 / ISO 12164-1 (HSK)



**CNC-Bohrfutter  
für Rechts- und Linkslauf**  
CNC-Drill chucks for clockwise  
and counter clockwise rotation  
Mandrins de perçage CNC  
pour rotation gauche-droite

DIN 69893

$\uparrow \leq 0,03$

G6,3  
15.000 min<sup>-1</sup>

CAD

Bestell-Nr. Order no. / Réf.	Abmessung Size / Dimension	Euro
A63.15.08	HSK 63 - 0,5/ 8 - 85	336,00
A63.15.13	HSK 63 - 1,0/ 13 - 104	315,00
A63.15.16	HSK 63 - 2,5/ 16 - 109	336,00
A100.15.13	HSK 100 - 1,0/ 13 - 107	402,00
A100.15.16	HSK 100 - 2,5/ 16 - 112	446,00

Mit zentraler Kühlmittelzufuhr

With centre coolant

Avec alimentation de liquide de refroidissement par le centre



**Bohrstangenrohlinge**  
Boring bar blanks  
Barres d'alésage

DIN 69893

CAD

Bestell-Nr. Order no. / Référence	Abmessung Size / Dimension	Euro
A63.17.63	HSK 63 - 63,5 - 250	125,00
A63.17.80	HSK 63 - 80 - 250	159,00
A100.17.97	HSK 100 - 97,5 - 250	206,00



**Gewindeschneidfutter für  
Synchronisation  
für Spannzangen DIN 6499  
(ISO 15488) System ER**

Tapping chucks for synchronisation  
for collets DIN 6499 (ISO  
15488) ER-system

Mandrins de taraudage pour  
synchronisation pour pinces DIN  
6499 (ISO 15488) système ER

DIN 69893

$\uparrow \leq 0,003$

G6,3  
15.000 min<sup>-1</sup>

CAD

Bestell-Nr. Order no. / Référence	Abmessung Size / Dimension	Euro
A63.16.02.10	HSK 63 - ER 16 - 89	619,00
A63.16.02.10.M*	HSK 63 - ER 16 - 89	562,00
A63.16.02.10.1.M*	HSK 63 - ER 16 - 100	576,00
A63.16.02.13	HSK 63 - ER 20 - 90	576,00
A63.16.02.16	HSK 63 - ER 25 - 94	597,00
A63.16.02.20	HSK 63 - ER 32 - 105	624,00
A63.16.02.26	HSK 63 - ER 40 - 133,5	624,00
A100.16.02.10	HSK 100 - ER 16 - 96	659,00
A100.16.02.10.M*	HSK 100 - ER 16 - 96	701,00
A100.16.02.10.1.M*	HSK 100 - ER 16 - 106	659,00
A100.16.02.13	HSK 100 - ER 20 - 97	701,00
A100.16.02.16	HSK 100 - ER 25 - 101	720,00
A100.16.02.20	HSK 100 - ER 32 - 110	749,00
A100.16.02.20.1	HSK 100 - ER 32 - 160	954,00
A100.16.02.20.2	HSK 100 - ER 32 - 190	1.062,00
A100.16.02.26	HSK 100 - ER 40 - 133	777,00

\*Mit Minimutter | \*With mini nut | \*Avec écrous-mini



Внимание! Данный прайс-лист для европейского рынка.  
Цены в РФ значительно отличаются от цен, указанных в данном документе!  
Для получения актуальной стоимости, обращайтесь по контактам, указанным ниже.



## Werkzeugaufnahmen DIN 69893 / ISO 12164-1 (HSK)

Toolholders DIN 69893 / ISO 12164-1 (HSK)

Porte-outils DIN 69893 / ISO 12164-1 (HSK)



**Hydro-Dehnspannfutter**  
Hydraulic expansion chucks  
Mandrins expansibles hydrauliques

DIN 69893

$\nearrow \leq 0,003$

G6,3  
15.000 min<sup>-1</sup>

CAD

Bestell-Nr. Order no. / Référence	Abmessung Size / Dimension	Euro
A63.H06	HSK 63 - 06 - 80	355,00
A63.H08	HSK 63 - 08 - 80	355,00
A63.H10	HSK 63 - 10 - 85	355,00
A63.H12	HSK 63 - 12 - 90	355,00
A63.H14	HSK 63 - 14 - 90	355,00
A63.H16	HSK 63 - 16 - 95	355,00
A63.H18	HSK 63 - 18 - 95	355,00
A63.H20	HSK 63 - 20 - 100	355,00
A63.H25	HSK 63 - 25 - 120	355,00
A63.H32	HSK 63 - 32 - 125	355,00

A63.H06.1	HSK 63 - 06 - 150	932,00
A63.H08.1	HSK 63 - 08 - 150	932,00
A63.H10.1	HSK 63 - 10 - 150	932,00
A63.H12.1	HSK 63 - 12 - 150	932,00
A63.H14.1	HSK 63 - 14 - 150	932,00
A63.H16.1	HSK 63 - 16 - 150	932,00
A63.H18.1	HSK 63 - 18 - 150	932,00
A63.H20.1	HSK 63 - 20 - 150	932,00
A63.H25.1	HSK 63 - 25 - 150	932,00

A63.H06.2	HSK 63 - 06 - 200	1004,00
A63.H08.2	HSK 63 - 08 - 200	1004,00
A63.H10.2	HSK 63 - 10 - 200	1004,00
A63.H12.2	HSK 63 - 12 - 200	1004,00
A63.H14.2	HSK 63 - 14 - 200	1004,00
A63.H16.2	HSK 63 - 16 - 200	1004,00
A63.H18.2	HSK 63 - 18 - 200	1004,00
A63.H20.2	HSK 63 - 20 - 200	1004,00
A63.H25.2	HSK 63 - 25 - 200	1004,00



**Hydro-Dehnspannfutter**  
Hydraulic expansion chucks  
Mandrins expansibles hydrauliques

DIN 69893

$\nearrow \leq 0,003$

G6,3  
15.000 min<sup>-1</sup>

CAD

Bestell-Nr. Order no. / Référence	Abmessung Size / Dimension	Euro
A100.H06	HSK 100 - 06 - 85	487,00
A100.H08	HSK 100 - 08 - 85	487,00
A100.H10	HSK 100 - 10 - 90	487,00
A100.H12	HSK 100 - 12 - 95	487,00
A100.H14	HSK 100 - 14 - 95	487,00
A100.H16	HSK 100 - 16 - 100	487,00
A100.H18	HSK 100 - 18 - 100	487,00
A100.H20	HSK 100 - 20 - 105	487,00
A100.H25	HSK 100 - 25 - 115	487,00
A100.H32	HSK 100 - 32 - 120	487,00

A100.H06.1	HSK 100 - 06 - 150	1033,00
A100.H08.1	HSK 100 - 08 - 150	1033,00
A100.H10.1	HSK 100 - 10 - 150	1033,00
A100.H12.1	HSK 100 - 12 - 150	1033,00
A100.H14.1	HSK 100 - 14 - 150	1033,00
A100.H16.1	HSK 100 - 16 - 150	1033,00
A100.H18.1	HSK 100 - 18 - 150	1033,00
A100.H20.1	HSK 100 - 20 - 150	1033,00
A100.H25.1	HSK 100 - 25 - 150	1033,00
A100.H32.1	HSK 100 - 32 - 150	1033,00

A100.H06.2	HSK 100 - 06 - 200	1144,00
A100.H08.2	HSK 100 - 08 - 200	1144,00
A100.H10.2	HSK 100 - 10 - 200	1144,00
A100.H12.2	HSK 100 - 12 - 200	1144,00
A100.H14.2	HSK 100 - 14 - 200	1144,00
A100.H16.2	HSK 100 - 16 - 200	1144,00
A100.H18.2	HSK 100 - 18 - 200	1144,00
A100.H20.2	HSK 100 - 20 - 200	1144,00
A100.H25.2	HSK 100 - 25 - 200	1144,00
A100.H32.2	HSK 100 - 32 - 200	1144,00

Внимание! Данный прайс-лист для европейского рынка.

Цены в РФ значительно отличаются от цен, указанных в данном документе!

Для получения актуальной стоимости, обращайтесь по контактам, указанным ниже.

kemmler@kemmler.su  
www.kemmler.su

## Werkzeugaufnahmen DIN 69893 / ISO 12164-1 (HSK)

Toolholders DIN 69893 / ISO 12164-1 (HSK)

Porte-outils DIN 69893 / ISO 12164-1 (HSK)



### Schrumpffutter zum Spannen von HM und HSS Werkzeugschäften

Shrink chucks for mounting of solid carbide and HSS-tool shanks  
Mandrins de frettage pour le serrage de queues d'outils carbures de type HM et HSS

DIN 69893

$\uparrow \leq 0,003$

G6,3  
15.000 min<sup>-1</sup>

CAD

Bestell-Nr. Order no. / Référence	Abmessung Size / Dimension	Euro
A63.70.03	HSK 63 - 03 - 80	158,00
A63.70.04	HSK 63 - 04 - 80	158,00
A63.70.05	HSK 63 - 05 - 80	158,00
A63.70.06	HSK 63 - 06 - 80	158,00
A63.70.08	HSK 63 - 08 - 80	158,00
A63.70.10	HSK 63 - 10 - 85	158,00
A63.70.12	HSK 63 - 12 - 90	158,00
A63.70.14	HSK 63 - 14 - 90	158,00
A63.70.16	HSK 63 - 16 - 95	158,00
A63.70.18	HSK 63 - 18 - 95	158,00
A63.70.20	HSK 63 - 20 - 100	158,00
A63.70.25	HSK 63 - 25 - 115	158,00
A63.70.32	HSK 63 - 32 - 120	158,00
A63.70.03.1	HSK 63 - 03 - 120	301,00
A63.70.04.1	HSK 63 - 04 - 120	301,00
A63.70.05.1	HSK 63 - 05 - 120	301,00
A63.70.06.1	HSK 63 - 06 - 120	271,00
A63.70.08.1	HSK 63 - 08 - 120	271,00
A63.70.10.1	HSK 63 - 10 - 120	271,00
A63.70.12.1	HSK 63 - 12 - 120	271,00
A63.70.14.1	HSK 63 - 14 - 120	271,00
A63.70.16.1	HSK 63 - 16 - 120	271,00
A63.70.18.1	HSK 63 - 18 - 120	271,00
A63.70.20.1	HSK 63 - 20 - 120	271,00
A63.70.25.1	HSK 63 - 25 - 120	271,00
A63.70.03.2	HSK 63 - 03 - 160	313,00
A63.70.04.2	HSK 63 - 04 - 160	313,00
A63.70.05.2	HSK 63 - 05 - 160	313,00
A63.70.06.2	HSK 63 - 06 - 160	283,00
A63.70.08.2	HSK 63 - 08 - 160	283,00
A63.70.10.2	HSK 63 - 10 - 160	283,00
A63.70.12.2	HSK 63 - 12 - 160	283,00
A63.70.14.2	HSK 63 - 14 - 160	283,00
A63.70.16.2	HSK 63 - 16 - 160	283,00
A63.70.18.2	HSK 63 - 18 - 160	283,00
A63.70.20.2	HSK 63 - 20 - 160	283,00
A63.70.25.2	HSK 63 - 25 - 160	283,00
A63.70.32.2	HSK 63 - 32 - 160	283,00



### Schrumpffutter zum Spannen von HM und HSS Werkzeugschäften

Shrink chucks for mounting of solid carbide and HSS-tool shanks  
Mandrins de frettage pour le serrage de queues d'outils carbures de type HM et HSS

DIN 69893

$\uparrow \leq 0,003$

G6,3  
15.000 min<sup>-1</sup>

CAD

Bestell-Nr. Order no. / Référence	Abmessung Size / Dimension	Euro
A63.70.06.3	HSK 63 - 06 - 200	325,00
A63.70.08.3	HSK 63 - 08 - 200	325,00
A63.70.10.3	HSK 63 - 10 - 200	325,00
A63.70.12.3	HSK 63 - 12 - 200	325,00
A63.70.14.3	HSK 63 - 14 - 200	325,00
A63.70.16.3	HSK 63 - 16 - 200	325,00
A63.70.18.3	HSK 63 - 18 - 200	325,00
A63.70.20.3	HSK 63 - 20 - 200	325,00
A63.70.25.3	HSK 63 - 25 - 200	325,00
A63.70.32.3	HSK 63 - 32 - 200	325,00



66

### Gewuchtete Ausführung

Balanced type  
Type équilibré

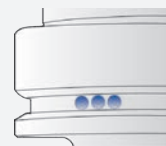

Bestell-Nr. Order no. / Référence	Abmessung Size / Dimension	Euro
<b>Wuchten auf G 2,5 von vorgewuchteten Kemmler-Werkzeugen</b>		
Balancing at G 2.5 of pre-balanced Kemmler-tools Équilibrage sur G 2,5 d'outils Kemmler pré-équilibrés		
W25	<b>Ohne Wuchtprotokoll</b> Without balancing report Sans protocole d'équilibrage	15,00
W25.2	<b>Mit Wuchtprotokoll</b> With balancing report Avec protocole d'équilibrage	19,00
<b>Wuchten von nicht vorgewuchteten Werkzeugen</b>		
Balancing of unbalanced tools Équilibrage d'outils non-équilibrés		
W25.1	<b>Ohne Wuchtprotokoll</b> Without balancing report Sans protocole d'équilibrage	28,00



Внимание! Данный прайс-лист для европейского рынка.  
Цены в РФ значительно отличаются от цен, указанных в данном документе!  
Для получения актуальной стоимости, обращайтесь по контактам, указанным ниже.



## Werkzeugaufnahmen DIN 69893 / ISO 12164-1 (HSK)

Toolholders DIN 69893 / ISO 12164-1 (HSK)

Porte-outils DIN 69893 / ISO 12164-1 (HSK)



### Schrumpffutter zum Spannen von HM und HSS Werkzeugschäften

Shrink chucks for mounting of  
solid carbide and HSS-tool shanks  
Mandrins de frettage pour le serrage  
de queues d'outils carbures de type  
HM et HSS

DIN 69893

$\nearrow \leq 0,003$

G6,3  
15.000 min<sup>-1</sup>

CAD

Bestell-Nr. Order no. / Référence	Abmessung Size / Dimension	Euro
A100.70.04	HSK 100 - 04 - 85	293,00
A100.70.05	HSK 100 - 05 - 85	293,00
A100.70.06	HSK 100 - 06 - 85	293,00
A100.70.08	HSK 100 - 08 - 85	293,00
A100.70.10	HSK 100 - 10 - 90	293,00
A100.70.12	HSK 100 - 12 - 95	293,00
A100.70.14	HSK 100 - 14 - 95	293,00
A100.70.16	HSK 100 - 16 - 100	293,00
A100.70.18	HSK 100 - 18 - 100	293,00
A100.70.20	HSK 100 - 20 - 105	293,00
A100.70.25	HSK 100 - 25 - 120	293,00
A100.70.32	HSK 100 - 32 - 120	293,00
A100.70.40	HSK 100 - 40 - 150	386,00
A100.70.50	HSK 100 - 50 - 150	403,00

A100.70.06.1	HSK 100 - 06 - 120	305,00
A100.70.08.1	HSK 100 - 08 - 120	305,00
A100.70.10.1	HSK 100 - 10 - 120	305,00
A100.70.12.1	HSK 100 - 12 - 120	305,00
A100.70.14.1	HSK 100 - 14 - 120	305,00
A100.70.16.1	HSK 100 - 16 - 120	305,00
A100.70.18.1	HSK 100 - 18 - 120	305,00
A100.70.20.1	HSK 100 - 20 - 120	305,00

A100.70.06.2	HSK 100 - 06 - 160	327,00
A100.70.08.2	HSK 100 - 08 - 160	327,00
A100.70.10.2	HSK 100 - 10 - 160	327,00
A100.70.12.2	HSK 100 - 12 - 160	327,00
A100.70.14.2	HSK 100 - 14 - 160	327,00
A100.70.16.2	HSK 100 - 16 - 160	327,00
A100.70.18.2	HSK 100 - 18 - 160	327,00
A100.70.20.2	HSK 100 - 20 - 160	327,00
A100.70.25.2	HSK 100 - 25 - 160	327,00
A100.70.32.2	HSK 100 - 32 - 160	327,00



### Schrumpffutter zum Spannen von HM und HSS Werkzeugschäften

Shrink chucks for mounting of  
solid carbide and HSS-tool shanks  
Mandrins de frettage pour le serrage  
de queues d'outils carbures de type  
HM et HSS

DIN 69893

$\nearrow \leq 0,003$

G6,3  
15.000 min<sup>-1</sup>

CAD

Bestell-Nr. Order no. / Référence	Abmessung Size / Dimension	Euro
A100.70.06.3	HSK 100 - 06 - 200	408,00
A100.70.08.3	HSK 100 - 08 - 200	408,00
A100.70.10.3	HSK 100 - 10 - 200	408,00
A100.70.12.3	HSK 100 - 12 - 200	408,00
A100.70.14.3	HSK 100 - 14 - 200	408,00
A100.70.16.3	HSK 100 - 16 - 200	408,00
A100.70.18.3	HSK 100 - 18 - 200	408,00
A100.70.20.3	HSK 100 - 20 - 200	408,00
A100.70.25.3	HSK 100 - 25 - 200	408,00
A100.70.32.3	HSK 100 - 32 - 200	408,00



Внимание! Данный прайс-лист для европейского рынка.

Цены в РФ значительно отличаются от цен, указанных в данном документе!

Для получения актуальной стоимости, обращайтесь по контактам, указанным ниже.

kemmler@kemmler.su

www.kemmler.su



## Werkzeugaufnahmen DIN 69893 / ISO 12164-1 (HSK)

Toolholders DIN 69893 / ISO 12164-1 (HSK)

Porte-outils DIN 69893 / ISO 12164-1 (HSK)

### Schrumpffutter mit Kühlkanälen zum Spannen von HM und HSS Werkzeugschäften

Shrink chucks with cooling channels for mounting of solid carbide and HSS-tool shanks

Mandrins de frettage avec canaux d'arrosage pour le serrage de queues d'outils carbures de type HM et HSS



DIN 69893

$\uparrow \leq 0,003$

G6.3  
15.000 min<sup>-1</sup>

CAD

Bestell-Nr. Order no. / Référence	Abmessung Size / Dimension	Euro
A63.70.06.K	HSK 63 - 06 - 80	289,00
A63.70.08.K	HSK 63 - 08 - 80	289,00
A63.70.10.K	HSK 63 - 10 - 85	289,00
A63.70.12.K	HSK 63 - 12 - 90	289,00
A63.70.14.K	HSK 63 - 14 - 90	289,00
A63.70.16.K	HSK 63 - 16 - 95	289,00
A63.70.18.K	HSK 63 - 18 - 95	289,00
A63.70.20.K	HSK 63 - 20 - 100	289,00
A63.70.25.K	HSK 63 - 25 - 115	289,00
A63.70.32.K	HSK 63 - 32 - 120	289,00

A63.70.06.2.K	HSK 63 - 06 - 160	347,00
A63.70.08.2.K	HSK 63 - 08 - 160	347,00
A63.70.10.2.K	HSK 63 - 10 - 160	347,00
A63.70.12.2.K	HSK 63 - 12 - 160	347,00
A63.70.14.2.K	HSK 63 - 14 - 160	347,00
A63.70.16.2.K	HSK 63 - 16 - 160	347,00
A63.70.18.2.K	HSK 63 - 18 - 160	347,00
A63.70.20.2.K	HSK 63 - 20 - 160	347,00
A63.70.25.2.K	HSK 63 - 25 - 160	347,00

A100.70.06.K	HSK 100 - 06 - 85	321,00
A100.70.08.K	HSK 100 - 08 - 85	321,00
A100.70.10.K	HSK 100 - 10 - 90	321,00
A100.70.12.K	HSK 100 - 12 - 95	321,00
A100.70.14.K	HSK 100 - 14 - 95	321,00
A100.70.16.K	HSK 100 - 16 - 100	321,00
A100.70.18.K	HSK 100 - 18 - 100	321,00
A100.70.20.K	HSK 100 - 20 - 105	321,00
A100.70.25.K	HSK 100 - 25 - 120	331,00
A100.70.32.K	HSK 100 - 32 - 120	331,00

A100.70.06.2.K	HSK 100 - 06 - 160	368,00
A100.70.08.2.K	HSK 100 - 08 - 160	368,00
A100.70.10.2.K	HSK 100 - 10 - 160	368,00
A100.70.12.2.K	HSK 100 - 12 - 160	368,00
A100.70.14.2.K	HSK 100 - 14 - 160	368,00
A100.70.16.2.K	HSK 100 - 16 - 160	368,00
A100.70.18.2.K	HSK 100 - 18 - 160	368,00
A100.70.20.2.K	HSK 100 - 20 - 160	368,00
A100.70.25.2.K	HSK 100 - 25 - 160	368,00
A100.70.32.2.K	HSK 100 - 32 - 160	350,00

### Schrumpfverlängerungen (mit Anschlag)

Shrink fit extensions (with end stop)

Rallonges de frettage (avec butée)

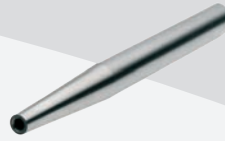

$\uparrow \leq 0,003$

CAD

Bestell-Nr. Order no. / Référence	Abmessung Size / Dimension	Euro
120.70.03	20 - 03 - 150	123,00
120.70.04	20 - 04 - 150	123,00
120.70.05	20 - 05 - 150	123,00
120.70.06	20 - 06 - 150	123,00
120.70.08	20 - 08 - 150	123,00
120.70.10	20 - 10 - 150	123,00
120.70.12	20 - 12 - 150	123,00



### Gewuchtete Ausführung

Balanced type

Type équilibré

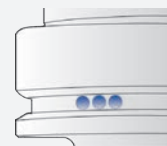

Bestell-Nr. Order no. / Référence	Abmessung Size / Dimension	Euro
--------------------------------------	-------------------------------	------

### Wuchten auf G 2,5 von vorgewuchteten Kemmler-Werkzeugen

Balancing at G 2.5 of pre-balanced Kemmler-tools

Équilibrage sur G 2,5 d'outils Kemmler pré-équilibrés

W25	<b>Ohne Wuchtprotokoll</b> Without balancing report Sans protocole d'équilibrage	15,00
W25.2	<b>Mit Wuchtprotokoll</b> With balancing report Avec protocole d'équilibrage	19,00

### Wuchten von nicht vorgewuchteten Werkzeugen

Balancing of unbalanced tools

Équilibrage d'outils non-équilibrés

W25.1	<b>Ohne Wuchtprotokoll</b> Without balancing report Sans protocole d'équilibrage	28,00
-------	----------------------------------------------------------------------------------------	-------

Внимание! Данный прайс-лист для европейского рынка.

Цены в РФ значительно отличаются от цен, указанных в данном документе!

Для получения актуальной стоимости, обращайтесь по контактам, указанным ниже.

**KEMMLER**

**65**



## Werkzeugaufnahmen DIN 69893 / ISO 12164-1 (HSK)

Toolholders DIN 69893 / ISO 12164-1 (HSK)

Porte-outils DIN 69893 / ISO 12164-1 (HSK)



### Kontrolldorne

Test arbors

Mandrins de contrôle

DIN 69893

$\uparrow \leq 0,003$

CAD

Bestell-Nr. Order no. / Référence	Abmessung Size / Dimension	Euro
A63.18.40	HSK 63 - 40 - 346	410,00
A100.18.50	HSK 100 - 50 - 349	450,00



### Holzkasten für Kontrolldorne

Wooden box for test arbors

Coffret en bois pour mandrins de contrôle

Bestell-Nr. Order no. / Référence	Abmessung Size / Dimension	Euro
701.18	460 x 130 x 115	96,00



### Kühlmittelübergabeeinheiten

Coolant tubes

Canules de lubrification

Bestell-Nr. Order no. / Référence	Abmessung Size / Dimension	Euro
A32.700	HSK 32	12,00
A40.700	HSK 40	12,00
A50.700	HSK 50	14,00
A63.700	HSK 63	11,00
A80.700	HSK 80	15,00
A100.700	HSK 100	14,00



### Schlüssel für

Kühlmittelübergabeeinheiten

Key for coolant tubes

Clés pour canules de lubrification

Bestell-Nr. Order no. / Référence	Abmessung Size / Dimension	Euro
A32.701	HSK 32	25,00
A40.701	HSK 40	25,00
A50.701	HSK 50	25,00
A63.701	HSK 63	21,00
A80.701	HSK 80	27,00
A100.701	HSK 100	24,00



## Werkzeugaufnahmen DIN 69893 / ISO 12164-1 (HSK)

Toolholders DIN 69893 / ISO 12164-1 (HSK)

Porte-outils DIN 69893 / ISO 12164-1 (HSK)



### Weitere Ausführungen auf Anfrage kurzfristig lieferbar

Other types available within a short period, upon request

D'autres types livrables dans un délai court, sur demande



**DIN 69063-1 (ISO 12164-1) Form A**  
 DIN 69063-1 (ISO 12164-1) Form A  
 DIN 69063-1 (ISO 12164-1) Forme A

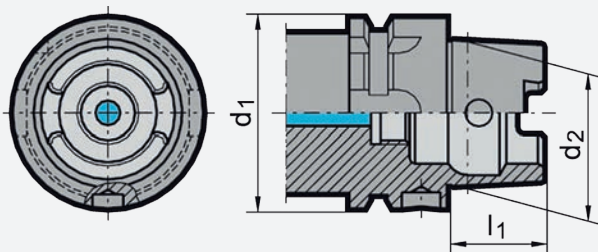

**DIN 69063-2 (ISO 12164-1) Form B**  
 DIN 69063-2 (ISO 12164-1) Form B  
 DIN 69063-2 (ISO 12164-1) Forme B

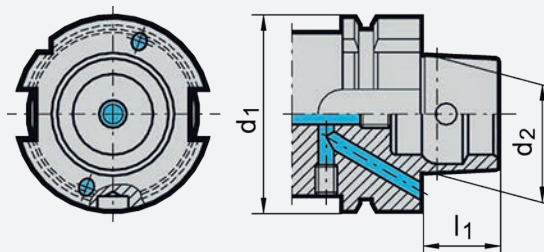

**DIN 69063-1 (ISO 12164-1) Form C**  
 DIN 69063-1 (ISO 12164-1) Form C  
 DIN 69063-1 (ISO 12164-1) Forme C

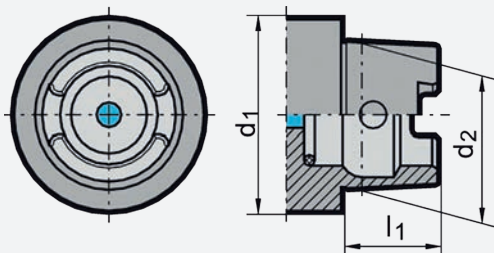

**DIN 69063-2 (ISO 12164-2) Form D**  
 DIN 69063-2 (ISO 12164-2) Form D  
 DIN 69063-2 (ISO 12164-2) Forme D

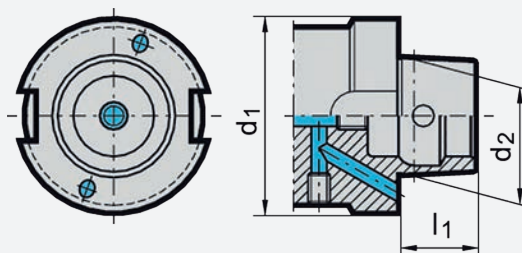

**DIN 69063-5 Form E**  
 DIN 69063-5 Form E  
 DIN 69063-5 Forme E

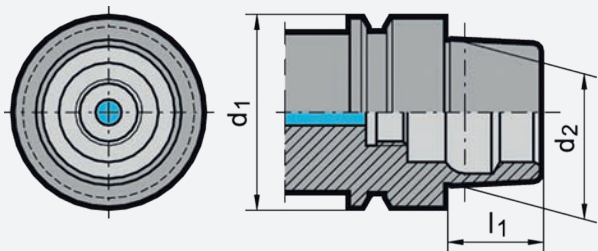

**DIN 69063-6 Form F**  
 DIN 69063-6 Form F  
 DIN 69063-6 Forme F

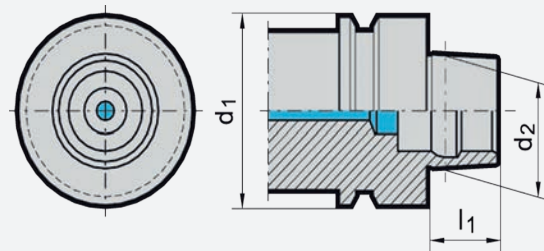

Внимание! Данный прайс-лист для европейского рынка.  
 Цены в РФ значительно отличаются от цен, указанных в данном документе!  
 Для получения актуальной стоимости, обращайтесь по контактам, указанным ниже.



## Werkzeugaufnahmen mit Polygonschaft ISO 26623-1

Toolholders with polygonal shank ISO 26623-1

Porte-outils à queue polygonale ISO 26623-1

Vorgewuchtet

Pre-balanced

Pré-équilibré

G 2,5 25.000 min<sup>-1</sup>

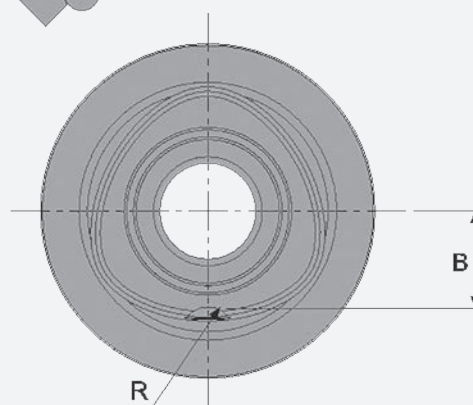
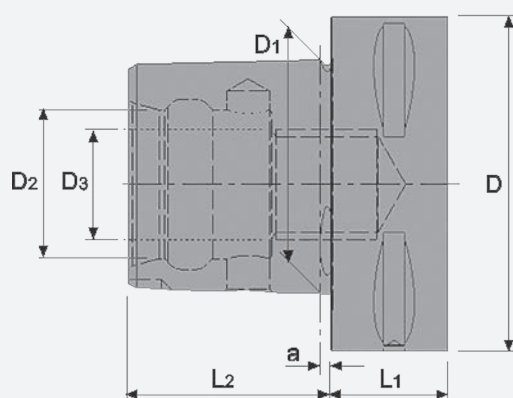
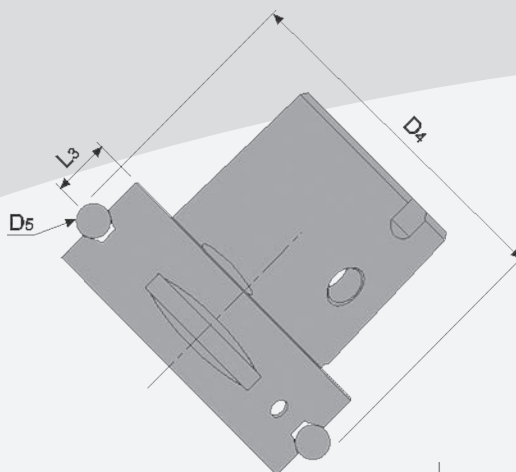

PSC	D	D <sub>1</sub>	D <sub>2</sub>	D <sub>3</sub>	D <sub>4</sub>	D <sub>5</sub>	L <sub>1 min</sub>	L <sub>2</sub>	L <sub>3</sub>	f <sub>3</sub>	a	B	R
63	63	44	28	M20 x 2,0	70,7	7	22	38	12	18	3,0	18,0	5

**Werkstoff:** Legierter Einsatzstahl mit einer Zugfestigkeit im Kern von min. 1200 N / mm<sup>2</sup>. Einsatzgehärtet HRC 60 ± 2 (HV 700 ± 50), Härtetiefe 0,8 mm ± 0,2 mm, brüniert und präzisionsgeschliffen.

**Material:** Alloyed case-hardened steel, tensile core strength of min. 1200 N / mm<sup>2</sup>. Case hardened HRC 60 ± 2 (HV 700 ± 50), hardening depth 0.8 mm ± 0.2 mm, black-finished and precisely grinded.

**Matière:** Acier de cémentation allié. Résistance à la traction dans le noyau de min 1200 N / mm<sup>2</sup>. Cémentation à HRC 60 ± 2 (HV 700 ± 50), profondeur de cémentation 0,8 mm ± 0,2 mm, bruni et rectifié précisément.

Внимание! Данный прайс-лист для европейского рынка.

Цены в РФ значительно отличаются от цен, указанных в данном документе!

Для получения актуальной стоимости, обращайтесь по контактам, указанным ниже.

## Inhaltsverzeichnis

Index

Table de matières



70



70



70



70



70



71



71

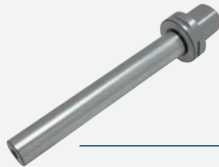

71



71

5



Внимание! Данный прайс-лист для европейского рынка.  
Цены в РФ значительно отличаются от цен, указанных в данном документе!  
Для получения актуальной стоимости, обращайтесь по контактам, указанным ниже.

kemmler@kemmler.su  
www.kemmler.su

KEMMLER

69





## Werkzeugaufnahmen mit Polygonschaft ISO 26623-1

Toolholders with polygonal shank ISO 26623-1

Porte-outils à queue polygonale ISO 26623-1



### Spannfutter für Spannzangen DIN 6499 (ISO 15488) System ER

Collet chucks for collets DIN 6499  
(ISO 15488) ER-system

Mandrins à pinces pour pinces  
DIN 6499 (ISO 15488) système ER



Bestell-Nr. Order no. / Réf.	Abmessung Size / Dimension	Euro
C6.02.16	C 6 - 2 / 16 - 60 ER 25	197,00
C6.02.20	C 6 - 2 / 20 - 70 ER 32	197,00
C6.02.26	C 6 - 3 / 26 - 65 ER 40	210,00
C6.02.10.1	C 6 - 1 / 10 - 100 ER 16	218,00
C6.02.16.1	C 6 - 2 / 16 - 100 ER 25	218,00
C6.02.20.1	C 6 - 2 / 20 - 100 ER 32	224,00



### Fräseraufnahmen DIN 6359 für Zylinderschäfte DIN 1835-B

End mill holders DIN 6359  
for end mills DIN 1835-B

Porte-fraises DIN 6359 pour queues  
cylindriques DIN 1835-B



Bestell-Nr. Order no. / Référence	Abmessung Size / Dimension	Euro
C6.04.06	C6 - 06 - 55	202,00
C6.04.08	C6 - 08 - 55	202,00
C6.04.10	C6 - 10 - 60	202,00
C6.04.12	C6 - 12 - 60	202,00
C6.04.14	C6 - 14 - 60	202,00
C6.04.16	C6 - 16 - 65	202,00
C6.04.18	C6 - 18 - 65	202,00
C6.04.20	C6 - 20 - 65	202,00
C6.04.25	C6 - 25 - 80	202,00
C6.04.32	C6 - 32 - 90	202,00
C6.04.40	C6 - 40 - 100	202,00



### Hochleistungs-Kraftspannfutter System HKS

High Performance Milling Chuck  
HKS-system

Mandrin de serrage  
à haute performance système HKS



Bestell-Nr. Order no. / Référence	Abmessung Size / Dimension	Euro
C6.64.20	C6 - 20 - 75	329,00
C6.64.32	C6 - 32 - 85	329,00



### Quernut-Aufsteckfräserdorne DIN 6357 mit vergrößerter Anlagefläche

Shell mill holders DIN 6357 with  
enlarged contact face

Porte-fraises à trou lisse DIN 6357  
avec face de contact élargie

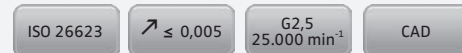

Bestell-Nr. Order no. / Référence	Abmessung Size / Dimension	Euro
C6.11.16	C6 - 16 - 40	231,00
C6.11.22	C6 - 22 - 40	231,00
C6.11.27	C6 - 27 - 30	231,00
C6.11.32	C6 - 32 - 45	231,00
C6.11.40	C6 - 40 - 45	231,00



### CNC-Bohrfutter für Rechts- und Linkslauf

CNC-Drill chucks for clockwise  
and counter clockwise rotation

Mandrins de perçage CNC  
pour rotation gauche-droite

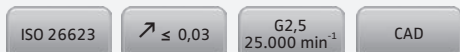

Bestell-Nr. Order no. / Référence	Abmessung Size / Dimension	Euro
C6.15.13	C6 - 1,0 / 13 - 104	515,00
C6.15.16	C6 - 2,5 / 16 - 109	520,00

Mit zentraler Kühlmittelzufuhr

With centre coolant

Avec alimentation de liquide de refroidissement par le centre

Внимание! Данный прайс-лист для европейского рынка.

Цены в РФ значительно отличаются от цен, указанных в данном документе!

Для получения актуальной стоимости, обращайтесь по контактам, указанным ниже.

## Werkzeugaufnahmen mit Polygonschaft ISO 26623-1

Toolholders with polygonal shank ISO 26623-1

Porte-outils à queue polygonale ISO 26623-1



### Kontrolldorne

Test arbors  
Mandrins de contrôle

ISO 26623

$\nabla \leq 0,003$

CAD

Bestell-Nr. Order no. / Référence	Abmessung Size / Dimension	Euro
C6.18.40	C6 - 40 - 182	678,00



### Holzkasten für Kontrolldorne

Wooden box for test arbors  
Coffret en bois pour mandrins de contrôle

Bestell-Nr. Order no. / Référence	Abmessung Size / Dimension	Euro
701.18	460 x 130 x 115	96,00

### Gewindeschneid-Schnellwechselfutter mit Längenausgleich auf Druck und Zug

Quick change tapping chucks **with** length compensation on compression and expansion  
Mandrins de taraudage à changement rapide **avec** compensation longitudinale à la compression et traction



ISO 26623

CAD

Bestell-Nr. Order no. / Réf.	Abmessung Size / Dimension		Euro
C6.16.12	C6 - M3 / M14	Gr. 1	756,00
C6.16.20	C6 - M5 / M22	Gr. 2	882,00
C6.16.36	C6 - M14 / M36	Gr. 3	1103,00



116



116



117



### Schrumpffutter zum Spannen von HM und HSS Werkzeugschäften

Shrink chucks for mounting of solid carbide and HSS-tool shanks  
Mandrins de frettage pour le serrage de queues d'outils carbures de type HM et HSS

ISO 26623

$\nabla \leq 0,003$

G2,5  
25.000 min<sup>-1</sup>

CAD

Bestell-Nr. Order no. / Référence	Abmessung Size / Dimension	Euro
C6.70.06	C6 - 06 - 80	288,00
C6.70.08	C6 - 08 - 80	288,00
C6.70.10	C6 - 10 - 80	275,00
C6.70.12	C6 - 12 - 80	275,00
C6.70.14	C6 - 14 - 85	275,00
C6.70.16	C6 - 16 - 85	275,00
C6.70.18	C6 - 18 - 85	275,00
C6.70.20	C6 - 20 - 85	275,00
C6.70.25	C6 - 25 - 90	302,00
C6.70.32	C6 - 32 - 95	302,00



### Bohrstangenrohlinge

Boring bar blanks  
Barres d'alésage

ISO 26623

CAD

Bestell-Nr. Order no. / Référence	Abmessung Size / Dimension	Euro
C6.17.63	C6 - 63 - 180	212,00
C6.17.120	C6 - 120 - 180	302,00



### Montageblock universal mit Kugellager

Universal ball bearing tightening fixture  
Bloc de montage universel avec palier à billes

Bestell-Nr. Order no. / Référence	Abmessung Size / Dimension	Euro
706.63	HSK63 - SK40 - BT40 - CAT40 - C6	209,00



Внимание! Данный прайс-лист для европейского рынка.  
Цены в РФ значительно отличаются от цен, указанных в данном документе!  
Для получения актуальной стоимости, обращайтесь по контактам, указанным ниже.



## Werkzeugaufnahmen DIN 69880 (VDI 3425)

Toolholders DIN 69880 (VDI 3425)

Porte-outils DIN 69880 (VDI 3425)

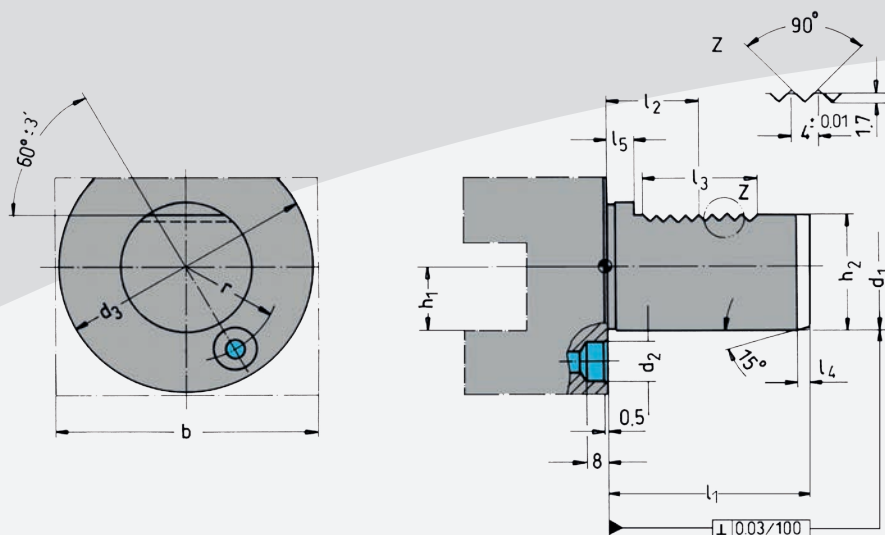

d <sub>1</sub> h <sub>6</sub>	b	h <sub>1</sub> max.	d <sub>2</sub>	d <sub>3</sub>	h <sub>2</sub> ± 0,1	r ± 0,02	l <sub>1</sub> max.	l <sub>2</sub> ± 0,05	l <sub>3</sub> max.	l <sub>4</sub> max.	l <sub>5</sub>
16	42	12	8	40	15,0	14,5	32	12,7	16	2	3,5
20	52	16	10	50	18,0	18,0	40	21,7	24	2	7,0
25	60	16	10	58	23,5	21,0	48	21,7	24	2	7,0
30	70	20	14	68	27,0	25,0	55	29,7	40	2	7,0
40	85	25	14	83	36,0	32,0	63	29,7	40	3	7,0
50	100	32	16	98	45,0	37,0	78	35,7	48	3	8,0

**Werkstoff:** Legierter Einsatzstahl mit einer Zugfestigkeit im Kern von min. 1200 N / mm<sup>2</sup>. Einsatzgehärtet HRC 60 ± 2 (HV 700 ± 50), Härtetiefe 0,8 mm ± 0,2 mm, brüniert und präzisionsgeschliffen.

**Ausführung:** Mit innerer Kühlmittelzufuhr bzw. mit Gewindeanschluss für externe Kühlmittelzufuhr.

**Material:** Alloyed case-hardened steel, tensile core strength of min. 1200 N / mm<sup>2</sup>. Case hardened HRC 60 ± 2 (HV 700 ± 50), hardening depth 0.8 mm ± 0.2 mm, black-finished and precisely grinded.

**Version:** With internal coolant resp. with threaded connection for external coolant.

**Matière:** Acier de cémentation allié. Résistance à la traction dans le noyau de min 1200 N / mm<sup>2</sup>. Cémentation à HRC 60 ± 2 (HV 700 ± 50), profondeur de cémentation 0,8 mm ± 0,2 mm, bruni et rectifié précisément.

**Version:** Avec arrosage interne respectivement avec raccord fileté pour arrosage externe.

### Werkzeugzuordnung für Scheibenrevolver

Tool assignment for disc turrets

Assignment des outils pour machines avec tourelle à disque

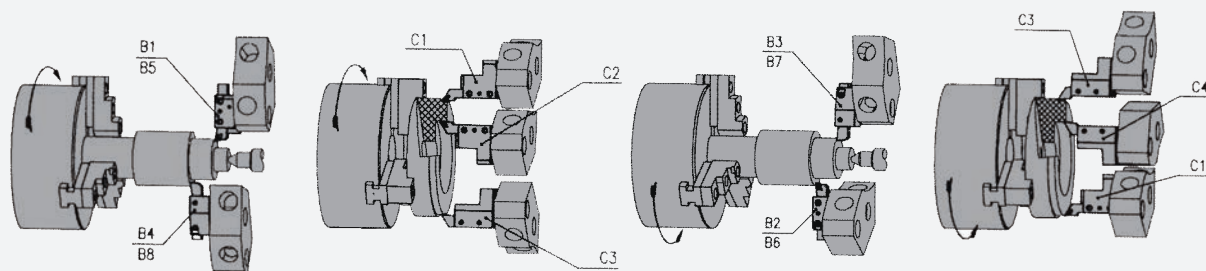

Einsatz von Werkzeughaltern bei linker Spindeldrehrichtung  
Application of tool holders with anti-clockwise spindle rotation  
Utilisation d'attachements avec la broche en sens anti-horaire

Einsatz von Werkzeughaltern bei rechter Spindeldrehrichtung  
Application of tool holders with clockwise spindle rotation  
Utilisation d'attachements avec la broche en sens horaire

Внимание! Данный прайс-лист для европейского рынка.

Цены в РФ значительно отличаются от цен, указанных в данном документе!













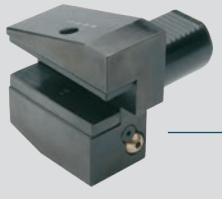











Для получения актуальной стоимости, обращайтесь по контактам, указанным ниже.



# Inhaltsverzeichnis

Index

Table de matières

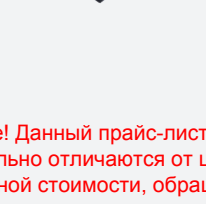
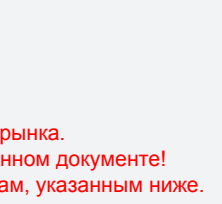
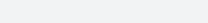
	_____ 74		_____ 74		_____ 74
	_____ 74		_____ 75		_____ 75
	_____ 75		_____ 75		_____ 76
	_____ 76		_____ 76		_____ 76
	_____ 77		_____ 77		_____ 78
	_____ 78		_____ 78		_____ 79
	_____ 79		_____ 80		_____ 80
	_____ 80		_____ 81		_____ 81
	_____ 82		_____ 82		_____ 83
	_____ 83				



Внимание! Данный прайс-лист для европейского рынка.  
 Цены в РФ значительно отличаются от цен, указанных в данном документе!  
 Для получения актуальной стоимости, обращайтесь по контактам, указанным ниже.



## Werkzeugaufnahmen DIN 69880 (VDI 3425)

Toolholders DIN 69880 (VDI 3425)

Porte-outils DIN 69880 (VDI 3425)



### Radial-Werkzeughalter Form B1 rechts, kurz

Radial toolholders form B1 right, short  
Porte-outils radials forme B1 droite, court

Bestell-Nr. Order no. / Référence	Abmessung Size / Dimension	Euro
169.31.12	B1 - 16 - 12 - 24	53,00
209.31.16	B1 - 20 - 16 - 30	53,00
309.31.20	B1 - 30 - 20 - 40	59,00
409.31.25	B1 - 40 - 25 - 44	69,00
509.31.32	B1 - 50 - 32 - 55	89,00



### Radial-Werkzeughalter Form B2 links, kurz

Radial toolholders form B2 left, short  
Porte-outils radials forme B2 gauche, court

Bestell-Nr. Order no. / Référence	Abmessung Size / Dimension	Euro
169.32.12	B2 - 16 - 12 - 24	53,00
209.32.16	B2 - 20 - 16 - 30	53,00
309.32.20	B2 - 30 - 20 - 40	59,00
409.32.25	B2 - 40 - 25 - 44	69,00
509.32.32	B2 - 50 - 32 - 55	89,00



### Radial-Werkzeughalter Form B3 Überkopf rechts, kurz

Radial toolholders form B3 overhead right, short  
Porte-outils radials forme B3 inversé droite, court

Bestell-Nr. Order no. / Référence	Abmessung Size / Dimension	Euro
169.33.12	B3 - 16 - 12 - 24	53,00
209.33.16	B3 - 20 - 16 - 30	53,00
309.33.20	B3 - 30 - 20 - 40	63,00
409.33.25	B3 - 40 - 25 - 44	72,00
509.33.32	B3 - 50 - 32 - 55	97,00



### Radial-Werkzeughalter Form B4 Überkopf links, kurz

Radial toolholders form B4 overhead left, short  
Porte-outils radials forme B4 inversé gauche, court

Bestell-Nr. Order no. / Référence	Abmessung Size / Dimension	Euro
169.34.12	B4 - 16 - 12 - 24	53,00
209.34.16	B4 - 20 - 16 - 30	53,00
309.34.20	B4 - 30 - 20 - 40	63,00
409.34.25	B4 - 40 - 25 - 44	72,00
509.34.32	B4 - 50 - 32 - 55	97,00

Alle Werkzeughalter werden mit Unterlegplatte geliefert.

All toolholders include a shim.

Tous les porte-outils inclus une entretoise.

Внимание! Данный прайс-лист для европейского рынка.

Цены в РФ значительно отличаются от цен, указанных в данном документе!

Для получения актуальной стоимости, обращайтесь по контактам, указанным ниже.



## Werkzeugaufnahmen DIN 69880 (VDI 3425)

Toolholders DIN 69880 (VDI 3425)

Porte-outils DIN 69880 (VDI 3425)



### Radial-Werkzeughalter Form B5 rechts, lang

Radial toolholders form B5

right, long

Porte-outils radials forme B5 droite, long

Bestell-Nr. Order no. / Référence	Abmessung Size / Dimension	Euro
169.35.12	B5 - 16 - 12 - 24	83,00
209.35.16	B5 - 20 - 16 - 30	87,00
309.35.20	B5 - 30 - 20 - 40	104,00
409.35.25	B5 - 40 - 25 - 44	121,00
509.35.32	B5 - 50 - 32 - 55	155,00



### Radial-Werkzeughalter Form B6 links, lang

Radial toolholders form B6

left, long

Porte-outils radials forme B6 gauche, long

Bestell-Nr. Order no. / Référence	Abmessung Size / Dimension	Euro
169.36.12	B6 - 16 - 12 - 24	83,00
209.36.16	B6 - 20 - 16 - 30	87,00
309.36.20	B6 - 30 - 20 - 40	104,00
409.36.25	B6 - 40 - 25 - 44	121,00
509.36.32	B6 - 50 - 32 - 55	155,00



### Radial-Werkzeughalter Form B7 Überkopf rechts, lang

Radial toolholders form B7

overhead right, long

Porte-outils radials forme B7 inversé droite, long

Bestell-Nr. Order no. / Référence	Abmessung Size / Dimension	Euro
169.37.12	B7 - 16 - 12 - 24	83,00
209.37.16	B7 - 20 - 16 - 30	87,00
309.37.20	B7 - 30 - 20 - 40	104,00
409.37.25	B7 - 40 - 25 - 44	121,00
509.37.32	B7 - 50 - 32 - 55	155,00



### Radial-Werkzeughalter Form B8 Überkopf links, lang

Radial toolholders form B8

overhead left, long

Porte-outils radials forme B8 inversé gauche, long

Bestell-Nr. Order no. / Référence	Abmessung Size / Dimension	Euro
169.38.12	B8 - 16 - 12 - 24	83,00
209.38.16	B8 - 20 - 16 - 30	87,00
309.38.20	B8 - 30 - 20 - 40	104,00
409.38.25	B8 - 40 - 25 - 44	121,00
509.38.32	B8 - 50 - 32 - 55	155,00



Alle Werkzeughalter werden mit Unterlegplatte geliefert.

All toolholders include a shim.

Tous les porte-outils inclus une entretoise.

Внимание! Данный прайс-лист для европейского рынка.

Цены в РФ значительно отличаются от цен, указанных в данном документе!

Для получения актуальной стоимости, обращайтесь по контактам, указанным ниже.

KEMMLER

75



## Werkzeugaufnahmen DIN 69880 (VDI 3425)

Toolholders DIN 69880 (VDI 3425)

Porte-outils DIN 69880 (VDI 3425)



### Axial-Werkzeughalter Form C1 rechts

Axial toolholders form C1 right  
Porte-outils axials forme C1 droite

Bestell-Nr. Order no. / Référence	Abmessung Size / Dimension	Euro
169.41.12	C1 - 16 - 12	63,00
209.41.16	C1 - 20 - 16	67,00
309.41.20	C1 - 30 - 20	79,00
409.41.25	C1 - 40 - 25	100,00
509.41.32	C1 - 50 - 32	131,00



### Axial-Werkzeughalter Form C2 links

Axial toolholders form C2 left  
Porte-outils axials forme C2 gauche

Bestell-Nr. Order no. / Référence	Abmessung Size / Dimension	Euro
169.42.12	C2 - 16 - 12	63,00
209.42.16	C2 - 20 - 16	67,00
309.42.20	C2 - 30 - 20	79,00
409.42.25	C2 - 40 - 25	100,00
509.42.32	C2 - 50 - 32	131,00



### Axial-Werkzeughalter Form C3 Überkopf rechts, kurz

Axial toolholders form C3 overhead  
right, short  
Porte-outils axials forme C3 inversé  
droite, court

Bestell-Nr. Order no. / Référence	Abmessung Size / Dimension	Euro
169.43.12	C3 - 16 - 12	63,00
209.43.16	C3 - 20 - 16	67,00
309.43.20	C3 - 30 - 20	79,00
409.43.25	C3 - 40 - 25	100,00
509.43.32	C3 - 50 - 32	136,00



### Axial-Werkzeughalter Form C4 Überkopf links, kurz

Axial toolholders form C4 overhead  
left, short  
Porte-outils axials forme C4 inversé  
gauche, court

Bestell-Nr. Order no. / Référence	Abmessung Size / Dimension	Euro
169.44.12	C4 - 16 - 12	63,00
209.44.16	C4 - 20 - 16	67,00
309.44.20	C4 - 30 - 20	79,00
409.44.25	C4 - 40 - 25	100,00
509.44.32	C4 - 50 - 32	136,00



Внимание! Данный прайс-лист для европейского рынка.

Цены в РФ значительно отличаются от цен, указанных в данном документе!

Для получения актуальной стоимости, обращайтесь по контактам, указанным ниже.

## Werkzeugaufnahmen DIN 69880 (VDI 3425)

Toolholders DIN 69880 (VDI 3425)

Porte-outils DIN 69880 (VDI 3425)



### Vierkant-Mehrfach-Aufnahme Form D1

Rectangular toolholders with multiple seats form D1  
Porte-outils, multiple, forme D1

Bestell-Nr. Order no. / Référence	Abmessung Size / Dimension	Euro
309.89.12	D1 - 30 - 20 - 76	113,00
409.89.16	D1 - 40 - 25 - 90	133,00
509.89.20	D1 - 50 - 32 - 105	163,00



### Vierkant-Mehrfach-Aufnahme, Überkopf, Form D2

Rectangular toolholders with multiple seats, overhead, form D2  
Porte-outils, multiple, inversé forme D2

Bestell-Nr. Order no. / Référence	Abmessung Size / Dimension	Euro
309.90.12	D2 - 30 - 20 - 76	113,00
409.90.16	D2 - 40 - 25 - 90	133,00
509.90.20	D2 - 50 - 32 - 105	163,00



### Abstechhalter rechts höhenverstellbar

Parting-off toolholders right height adjustable  
Porte-lames de tronçonnage droite réglage en hauteur

Bestell-Nr. Order no. / Référence	Abmessung Size / Dimension	Euro
309.65.26	AR - 30 - 26	336,00
409.65.32	AR - 40 - 32	357,00
509.65.32	AR - 50 - 32	383,00



### Abstechhalter links höhenverstellbar

Parting-off toolholders left height adjustable  
Porte-lames de tronçonnage gauche réglage en hauteur

Bestell-Nr. Order no. / Référence	Abmessung Size / Dimension	Euro
309.66.26	AL - 30 - 26	336,00
409.66.32	AL - 40 - 32	357,00
509.66.32	AL - 50 - 32	383,00



Внимание! Данный прайс-лист для европейского рынка.  
Цены в РФ значительно отличаются от цен, указанных в данном документе!  
Для получения актуальной стоимости, обращайтесь по контактам, указанным ниже.



## Werkzeugaufnahmen DIN 69880 (VDI 3425)

Toolholders DIN 69880 (VDI 3425)

Porte-outils DIN 69880 (VDI 3425)

### Spannfutter Form E3 DIN 6391 für Spannzangen DIN 6388 (ISO 10897) System OZ

Collet chucks form E3 DIN 6391 for collets DIN 6388 (ISO 10897) OZ-system  
Mandrins à pinces forme E3 DIN 6391 pour pinces DIN 6388 (ISO 10897) système OZ



Bestell-Nr. Order no. / Référence	Abmessung Size / Dimension	Euro
169.01.16	E3 - 16 - 2 / 16 OZ 16	98,00
209.01.16	E3 - 20 - 2 / 16 OZ 16	101,00
309.01.16	E3 - 30 - 2 / 16 OZ 16	104,00
309.01.25	E3 - 30 - 2 / 25 OZ 25	98,00
409.01.25	E3 - 40 - 2 / 25 OZ 25	104,00
409.01.32	E3 - 40 - 3 / 32 OZ 32	110,00
509.01.25	E3 - 50 - 2 / 25 OZ 25	121,00
509.01.32	E3 - 50 - 3 / 32 OZ 32	126,00



90

108

### Spannfutter Form E4 für Spannzangen DIN 6499 (ISO 15488) System ER

Collet chucks form E4 for collets DIN 6499 (ISO 15488) ER-system  
Mandrins à pinces forme E4 pour pinces DIN 6499 (ISO 15488) système ER



Bestell-Nr. Order no. / Référence	Abmessung Size / Dimension	Euro
169.02.10	E4 - 16 - 1 / 10 ER 16	89,00
209.02.10	E4 - 20 - 1 / 10 ER 16	89,00
209.02.16	E4 - 20 - 2 / 16 ER 25	84,00
309.02.16	E4 - 30 - 2 / 16 ER 25	86,00
309.02.20	E4 - 30 - 2 / 20 ER 32	86,00
309.02.26	E4 - 30 - 3 / 26 ER 40	86,00
409.02.16	E4 - 40 - 2 / 16 ER 25	89,00
409.02.20	E4 - 40 - 2 / 20 ER 32	89,00
409.02.26	E4 - 40 - 3 / 26 ER 40	89,00
509.02.26	E4 - 50 - 3 / 26 ER 40	121,00



90

108

### Bohrerhalter für Wendeplattenbohrer Form E1

Boring holders for drills with indexable inserts form E1  
Portes forets pour forets à plaquettes réversibles forme E1



Bestell-Nr. Order no. / Référence	Abmessung Size / Dimension	Euro
209.51.16	E1 - 20 - 16	66,00
209.51.20	E1 - 20 - 20	66,00
209.51.25	E1 - 20 - 25	66,00
309.51.16	E1 - 30 - 16	69,00
309.51.20	E1 - 30 - 20	69,00
309.51.25	E1 - 30 - 25	69,00
309.51.32	E1 - 30 - 32	69,00
309.51.40	E1 - 30 - 40	69,00
409.51.16	E1 - 40 - 16	72,00
409.51.20	E1 - 40 - 20	72,00
409.51.25	E1 - 40 - 25	72,00
409.51.32	E1 - 40 - 32	72,00
409.51.40	E1 - 40 - 40	72,00
509.51.16	E1 - 50 - 16	96,00
509.51.20	E1 - 50 - 20	96,00
509.51.25	E1 - 50 - 25	96,00
509.51.32	E1 - 50 - 32	96,00
509.51.40	E1 - 50 - 40	96,00
509.51.50	E1 - 50 - 50	96,00



6

Внимание! Данный прайс-лист для европейского рынка.

Цены в РФ значительно отличаются от цен, указанных в данном документе!

Для получения актуальной стоимости, обращайтесь по контактам, указанным ниже.

kemmler@kemmler.su  
www.kemmler.su

## Werkzeugaufnahmen DIN 69880 (VDI 3425)

Toolholders DIN 69880 (VDI 3425)

Porte-outils DIN 69880 (VDI 3425)



**Bohrstangenhalter Form E2**  
Boring bar holders form E2  
Porte-outils pour barres d'alésage  
forme E2

Bestell-Nr. Order no. / Référence	Abmessung Size / Dimension	Euro
169.52.06	E2 - 16 - 06	63,00
169.52.08	E2 - 16 - 08	63,00
169.52.10	E2 - 16 - 10	63,00
169.52.12	E2 - 16 - 12	63,00
169.52.16	E2 - 16 - 16	63,00
209.52.08	E2 - 20 - 08	63,00
209.52.10	E2 - 20 - 10	63,00
209.52.12	E2 - 20 - 12	63,00
209.52.16	E2 - 20 - 16	63,00
209.52.20	E2 - 20 - 20	63,00
309.52.08	E2 - 30 - 08	66,00
309.52.10	E2 - 30 - 10	66,00
309.52.12	E2 - 30 - 12	66,00
309.52.16	E2 - 30 - 16	66,00
309.52.20	E2 - 30 - 20	66,00
309.52.25	E2 - 30 - 25	66,00
309.52.32	E2 - 30 - 32	66,00
409.52.08	E2 - 40 - 08	69,00
409.52.10	E2 - 40 - 10	69,00
409.52.12	E2 - 40 - 12	69,00
409.52.16	E2 - 40 - 16	69,00
409.52.20	E2 - 40 - 20	69,00
409.52.25	E2 - 40 - 25	69,00
409.52.32	E2 - 40 - 32	69,00
409.52.40	E2 - 40 - 40	69,00
509.52.12	E2 - 50 - 12	93,00
509.52.16	E2 - 50 - 16	93,00
509.52.20	E2 - 50 - 20	93,00
509.52.25	E2 - 50 - 25	93,00
509.52.32	E2 - 50 - 32	93,00
509.52.40	E2 - 50 - 40	93,00
509.52.50	E2 - 50 - 50	93,00



Form 1



Form 2

**Reduzierbuchsen  
für Bohrstangenhalter Form E2**  
Reduction sleeves  
for boring bar holders form E2  
Douilles de réduction  
pour barres d'alésage forme E2

Bestell-Nr. Order no. / Référence	Abmessung Size / Dimension	Form Form / Forme	Euro
709.25.06	Ø 25 - 06 - 46	1	29,00
709.25.08	Ø 25 - 08 - 46	1	29,00
709.25.10	Ø 25 - 10 - 46	1	29,00
709.25.12	Ø 25 - 12 - 46	1	29,00
709.25.14	Ø 25 - 14 - 46	2	29,00
709.25.16	Ø 25 - 16 - 46	2	29,00
709.25.18	Ø 25 - 18 - 46	2	29,00
709.25.20	Ø 25 - 20 - 46	2	29,00
709.32.06	Ø 32 - 06 - 56	1	30,00
709.32.08	Ø 32 - 08 - 56	1	30,00
709.32.10	Ø 32 - 10 - 56	1	30,00
709.32.12	Ø 32 - 12 - 56	1	30,00
709.32.14	Ø 32 - 14 - 56	2	30,00
709.32.16	Ø 32 - 16 - 56	2	30,00
709.32.18	Ø 32 - 18 - 56	2	30,00
709.32.20	Ø 32 - 20 - 56	2	30,00
709.32.25	Ø 32 - 25 - 56	2	30,00
709.40.06	Ø 40 - 06 - 71	1	32,00
709.40.08	Ø 40 - 08 - 71	1	32,00
709.40.10	Ø 40 - 10 - 71	1	32,00
709.40.12	Ø 40 - 12 - 71	1	32,00
709.40.14	Ø 40 - 14 - 71	2	32,00
709.40.16	Ø 40 - 16 - 71	2	32,00
709.40.18	Ø 40 - 18 - 71	2	32,00
709.40.20	Ø 40 - 20 - 71	2	32,00
709.40.25	Ø 40 - 25 - 71	2	32,00
709.40.32	Ø 40 - 32 - 71	2	32,00



Внимание! Данный прайс-лист для европейского рынка.  
Цены в РФ значительно отличаются от цен, указанных в данном документе!  
Для получения актуальной стоимости, обращайтесь по контактам, указанным ниже.





## Werkzeugaufnahmen DIN 69880 (VDI 3425)

Toolholders DIN 69880 (VDI 3425)

Porte-outils DIN 69880 (VDI 3425)



### Bohrfutteraufnahmen DIN 238

Drill chuck adaptors DIN 238

Arbres pour mandrins de perçage  
DIN 238

Bestell-Nr. Order no. / Référence	Abmessung Size / Dimension	Euro
309.14.16	30 - B16	59,00
409.14.16	40 - B16	61,00
509.14.16	50 - B16	75,00



### Zwischenhülsen für MK mit Austreibklappen Form F1

Adaptor sleeves for MT,  
tanged, form F1

Douilles de réduction pour CM  
à tenon forme F1

Bestell-Nr. Order no. / Référence	Abmessung Size / Dimension	Euro
169.07.01	F1 - 16 - MK 1	84,00
209.07.01	F1 - 20 - MK 1	79,00
209.07.02	F1 - 20 - MK 2	79,00
309.07.01	F1 - 30 - MK 1	69,00
309.07.02	F1 - 30 - MK 2	69,00
309.07.03	F1 - 30 - MK 3	69,00
409.07.02	F1 - 40 - MK 2	72,00
409.07.03	F1 - 40 - MK 3	72,00
409.07.04	F1 - 40 - MK 4	72,00
509.07.02	F1 - 50 - MK 2	90,00
509.07.03	F1 - 50 - MK 3	90,00
509.07.04	F1 - 50 - MK 4	90,00
509.07.05	F1 - 50 - MK 5	112,00



### CNC-Bohrfutter mit Kühlmittelzuführung über Kugelspritzdüsen

CNC-Drill chucks with coolant  
supply via spray nozzles

Mandrins de perçage CNC  
avec arrosage par gicleurs

Bestell-Nr. Order no. / Référence	Abmessung Size / Dimension	Euro
169.15.10.K	16 - 1,0 / 10 - 41	361,00
209.15.10.K	20 - 1,0 / 10 - 41	361,00
309.15.13.K	30 - 1,0 / 13 - 87	361,00
309.15.16.K	30 - 2,5 / 16 - 92	388,00
409.15.13.K	40 - 1,0 / 13 - 88	369,00
409.15.16.K	40 - 2,5 / 16 - 93	392,00
509.15.16.K	50 - 2,5 / 16 - 102	428,00



### CNC-Bohrfutter mit zentraler Kühlmittelzufuhr

CNC-Drill chucks  
with central coolant

Mandrins de perçage CNC  
avec arrosage centrale

Bestell-Nr. Order no. / Référence	Abmessung Size / Dimension	Euro
209.15.13	20 - 1,0 / 13 - 90	268,00
309.15.13	30 - 1,0 / 13 - 93	268,00
309.15.16	30 - 2,5 / 16 - 98	279,00
409.15.13	40 - 1,0 / 13 - 93	268,00
409.15.16	40 - 2,5 / 16 - 98	279,00
509.15.13	50 - 1,0 / 13 - 101	302,00
509.15.16	50 - 2,5 / 16 - 106	312,00

Внимание! Данный прайс-лист для европейского рынка.

Цены в РФ значительно отличаются от цен, указанных в данном документе!

Для получения актуальной стоимости, обращайтесь по контактам, указанным ниже.

## Werkzeugaufnahmen DIN 69880 (VDI 3425)

Toolholders DIN 69880 (VDI 3425)

Porte-outils DIN 69880 (VDI 3425)

### Гewindeschneid-Schnellwechsel- futter mit Längenausgleich auf Druck und Zug

Quick-change tapping chucks with length compensation on compression and expansion

Mandrins de taraudage à changement rapide avec compensation longitudinale à la compression et traction



Bestell-Nr. Order no. / Référence	Abmessung Size / Dimension	Euro
209.16.12	20 - M3 / M14 Gr. 1	329,00
309.16.12	30 - M3 / M14 Gr. 1	223,00
309.16.20	30 - M5 / M22 Gr. 2	296,00
409.16.12	40 - M3 / M14 Gr. 1	251,00
409.16.20	40 - M5 / M22 Gr. 2	302,00
509.16.12	50 - M3 / M14 Gr. 1	353,00
509.16.20	50 - M5 / M22 Gr. 2	540,00



### Гewindeschneid-Schnellwechsel- futter ohne Längenausgleich auf Druck und Zug

Quick-change tapping chucks without length compensation on compression and expansion

Mandrins de taraudage à changement rapide sans compensation longitudinale à la compression et traction



Bestell-Nr. Order no. / Référence	Abmessung Size / Dimension	Euro
309.16.12.1	30 - M3 / M14 Gr. 1	179,00
309.16.20.1	30 - M5 / M22 Gr. 2	191,00
409.16.12.1	40 - M3 / M14 Gr. 1	179,00
409.16.20.1	40 - M5 / M22 Gr. 2	191,00



### Schutzstopfen aus Stahl Form Z2

Protection steel plugs form Z2  
Bouchons de protection en acier  
forme Z2



Bestell-Nr. Order no. / Référence	Abmessung Size / Dimension	Euro
169.29.13	16 - 13	27,00
209.29.16	20 - 16	27,00
309.29.20	30 - 16	21,00
409.29.20	40 - 20	25,00
509.29.20	50 - 20	34,00

### Schutzstopfen aus Kunststoff Form Z2

Protection plastic plugs form Z2  
Bouchons de protection en plastique  
forme Z2

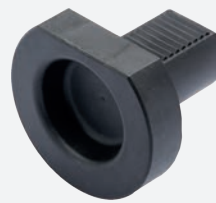

Bestell-Nr. Order no. / Référence	Abmessung Size / Dimension	Euro
169.30.13	16 - 13	17,00
209.30.16	20 - 16	13,00
309.30.16	30 - 16	13,00
409.30.20	40 - 20	13,00
509.30.20	50 - 20	28,00



Внимание! Данный прайс-лист для европейского рынка.  
Цены в РФ значительно отличаются от цен, указанных в данном документе!  
Для получения актуальной стоимости, обращайтесь по контактам, указанным ниже.



## Werkzeugaufnahmen DIN 69880 (VDI 3425)

Toolholders DIN 69880 (VDI 3425)

Porte-outils DIN 69880 (VDI 3425)



### Kontrolldorne

Test arbors

Mandrins de contrôle

Bestell-Nr. Order no. / Référence	Abmessung Size / Dimension	Euro
169.18.30	16 - 30 - 120	260,00
209.18.40	20 - 40 - 150	287,00
309.18.40	30 - 40 - 200	307,00
409.18.40	40 - 40 - 200	323,00
509.18.40	50 - 40 - 200	359,00



### Werkzeughalter Rohling Form A1, rechteckig

Soft blank form A1, rectangular

Porte-outils ebauche

forme A1, rectangle

Bestell-Nr. Order no. / Réf.	Abmessung Size / Dimension	Euro
169.17.12	16 - 78 - 44 - 44	50,00
209.17.16	20 - 100 - 60 - 65	62,00
309.17.20	30 - 130 - 76 - 85	83,00
409.17.25	40 - 151 - 96 - 100	152,00
509.17.32	50 - 160 - 120 - 125	184,00



### Holzkasten für Kontrolldorne

Wooden box for test arbors

Coffret en bois pour mandrins

de contrôle

Bestell-Nr. Order no. / Référence	Abmessung Size / Dimension	Euro
701.18	460 x 130 x 115	96,00



### Werkzeughalter Rohling Form A2, rund

Soft blank form A2, round

Porte-outils ebauche forme A2, ronde

Bestell-Nr. Order no. / Référence	Abmessung Size / Dimension	Euro
169.19.12	16 - 40 - 60	33,00
209.19.16	20 - 50 - 70	34,00
309.19.20	30 - 68 - 100	40,00
309.19.21	30 - 68 - 240	56,00
409.19.20	40 - 83 - 120	50,00
409.19.21	40 - 83 - 320	97,00
509.19.32	50 - 98 - 135	86,00
509.19.33	50 - 98 - 400	155,00



Внимание! Данный прайс-лист для европейского рынка.

Цены в РФ значительно отличаются от цен, указанных в данном документе!

Для получения актуальной стоимости, обращайтесь по контактам, указанным ниже.

## Werkzeugaufnahmen DIN 69880 (VDI 3425)

Toolholders DIN 69880 (VDI 3425)

Porte-outils DIN 69880 (VDI 3425)



**Hydro-Dehnspannfutter**  
Hydraulic expansion chucks  
Mandrins expansibles hydrauliques

Bestell-Nr. Order no. / Référence	Abmessung Size / Dimension	Euro
309.H06	30 - 06 - 49	815,00
309.H08	30 - 08 - 49	815,00
309.H10	30 - 10 - 49	815,00
309.H12	30 - 12 - 54	815,00
309.H14	30 - 14 - 54	815,00
309.H16	30 - 16 - 89	815,00
309.H18	30 - 18 - 89	815,00
309.H20	30 - 20 - 89	815,00
309.H25	30 - 25 - 84	815,00
309.H32	30 - 32 - 84	815,00
409.H06	40 - 06 - 55	845,00
409.H08	40 - 08 - 55	845,00
409.H10	40 - 10 - 55	845,00
409.H12	40 - 12 - 60	845,00
409.H14	40 - 14 - 60	845,00
409.H16	40 - 16 - 95	845,00
409.H18	40 - 18 - 95	845,00
409.H20	40 - 20 - 95	845,00
409.H25	40 - 25 - 95	845,00
409.H32	40 - 32 - 95	845,00
509.H06	50 - 06 - 55	1046,00
509.H08	50 - 08 - 55	1046,00
509.H10	50 - 10 - 55	1046,00
509.H12	50 - 12 - 60	1046,00
509.H14	50 - 14 - 60	1046,00
509.H16	50 - 16 - 95	1046,00
509.H18	50 - 18 - 95	1046,00
509.H20	50 - 20 - 95	1046,00
509.H25	50 - 25 - 95	1046,00
509.H32	50 - 32 - 95	1046,00

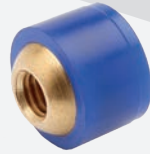

**Kunststoff-Kugelspritzdüsen**  
Plastic ball sprayer nozzles  
Gicleurs en plastique

Bestell-Nr. Order no. / Réf.	Abmessung Size / Dimension	Euro
703.10	10	5,00
703.12	12	5,00
703.14	14	6,00



**Kugelspritzdüsen (Messing)**  
Ball sprayer nozzles (brass)  
Gicleurs (laiton)

Bestell-Nr. Order no. / Réf.	Abmessung Size / Dimension	Euro
703.08.ME	8	9,00
703.10.ME	10	9,00
703.12.ME	12	9,00
703.14.ME	14	9,00



**Unterlegplatten**  
Shim  
Sous-plaquettes

Bestell-Nr. Order no. / Réf.	Abmessung Size / Dimension	Euro
209.16.01	14 x 4 x 54	9,00
309.20.01	18 x 4 x 69	9,00
409.25.01	22 x 5 x 84	9,00
509.32.01	25 x 7 x 99	9,00



Внимание! Данный прайс-лист для европейского рынка.  
Цены в РФ значительно отличаются от цен, указанных в данном документе!  
Для получения актуальной стоимости, обращайтесь по контактам, указанным ниже.



## Werkzeugaufnahmen MK DIN 228-1 A und DIN 228-1 B

Toolholders MT DIN 228-1 A and DIN 228-1 B

Porte-outils CM DIN 228-1 A et DIN 228-1 B

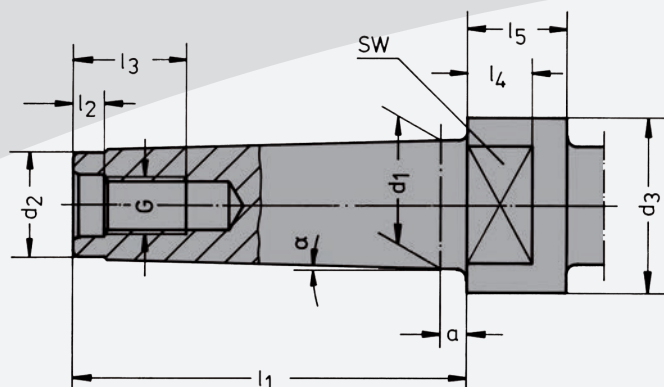

MK	$\alpha$	G	a	d <sub>1</sub>	d <sub>2</sub> max.	d <sub>3</sub>	SW d <sup>9</sup>	l <sub>1</sub>	l <sub>2</sub>	l <sub>3</sub>	l <sub>4</sub>	l <sub>5</sub>
1	1°25'43"	M6	3,5	12,065	9	–	–	–	4	16	–	–
2	1°25'50"	M10	5	17,780	14	–	–	–	5	24	–	–
3	1°26'16"	M12	5	23,825	19	36	24	86	5,5	24	12	18
4	1°29'15"	M16	6,5	31,267	25	43	32	109	8,2	32	15	23
5	1°30'26"	M20	6,5	44,399	35,7	60	45	136	10	40	18	28
6	1°29'36"	M24	8	63,348	51	84	65	190	11,5	47	25	39

**Werkstoff:** Legierter Einsatzstahl mit einer Zugfestigkeit im Kern von min. 1200 N/mm<sup>2</sup>  
Einsatzgehärtet HRC 60 ± 2 (HV 700 ± 50), Härtetiefe 0,8 mm ± 0,2 mm,  
brüniert und präzisionsgeschliffen.

**Material:** Alloyed case hardened steel, tensile strength in the core of min. 1200 N/mm<sup>2</sup>  
Case hardened HRC 60 ± 2 (HV 700 ± 50), hardening depth 0.8 mm ± 0.2 mm,  
black-finished and precisely grinded.

**Matière:** Châssis d'allié en acier de cémentation. Résistance à la traction dans le noyau  
de min 1200 N/mm<sup>2</sup>  
Trempe à HRC 60 ± 2 (HV 700 ± 50), profondeur de trempé 0,8 mm ± 0,2 mm,  
bruni et rectifié précisément.





## Inhaltsverzeichnis

Index

Table de matières

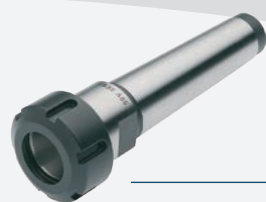

86



86



86



87



87



87



87



87

7



Внимание! Данный прайс-лист для европейского рынка.  
Цены в РФ значительно отличаются от цен, указанных в данном документе!  
Для получения актуальной стоимости, обращайтесь по контактам, указанным ниже.

kemmler@kemmler.su  
www.kemmler.su

**KEMMLER**

**85**



## Werkzeugaufnahmen MK DIN 228-1 A und DIN 228-1 B

Toolholders MT DIN 228-1 A and DIN 228-1 B

Porte-outils CM DIN 228-1 A et DIN 228-1 B



### Spannfutter für Spannzangen DIN 6499 (ISO 15488) System ER

Collet chucks for collets DIN 6499  
(ISO 15488) ER-system

Mandrins à pinces  
DIN 6499 (ISO 15488) système ER

DIN 228-1 A

$\nabla \leq 0,008$

G6.3  
15.000 min<sup>-1</sup>

Bestell-Nr. Order no. / Référence	Abmessung Size / Dimension	Euro
108.02.01	MK 2 / M10 - ER 16 - 45	105,00
108.02.011	MK 2 / M10 - ER 25 - 50	105,00
108.02.02	MK 3 / M12 - ER 25 - 56	139,00
108.02.03	MK 3 / M12 - ER 32 - 70	139,00
108.02.04	MK 4 / M16 - ER 25 - 63	163,00
108.02.05	MK 4 / M16 - ER 32 - 65	163,00
108.02.06	MK 5 / M20 - ER 40 - 86	241,00



### Kombi-Aufsteckfräserdorne DIN 6358

Combi shell mill holders DIN 6358  
Porte-fraises à double usage  
DIN 6358

DIN 228-1 A

$\nabla \leq 0,008$

Bestell-Nr. Order no. / Référence	Abmessung Size / Dimension	Euro
108.10.20	MK 2 / M10 - 16 - 43	83,00
108.10.21	MK 2 / M10 - 22 - 43	83,00
108.10.30	MK 3 / M12 - 16 - 48	77,00
108.10.31	MK 3 / M12 - 22 - 48	83,00
108.10.32	MK 3 / M12 - 27 - 48	97,00
108.10.33	MK 3 / M12 - 32 - 48	105,00
108.10.40	MK 4 / M16 - 16 - 55	98,00
108.10.41	MK 4 / M16 - 22 - 55	101,00
108.10.42	MK 4 / M16 - 27 - 55	105,00
108.10.43	MK 4 / M16 - 32 - 55	122,00
108.10.50	MK 5 / M20 - 22 - 75	121,00
108.10.51	MK 5 / M20 - 27 - 75	125,00
108.10.52	MK 5 / M20 - 32 - 75	133,00
108.10.53	MK 5 / M20 - 40 - 75	143,00



### Gewindeschneid-Schnellwechselfutter mit Längenausgleich auf Druck und Zug

Quick-change tapping chucks with length compensation on compression and expansion

Mandrins de taraudage à changement rapide avec compensation longitudinale à la compression et traction

DIN 228-1 B

Bestell-Nr. Order no. / Référence	Abmessung Size / Dimension	Euro
107.16.212	MK 2 - M3 / M14 Gr. 1	135,00
107.16.312	MK 3 - M3 / M14 Gr. 1	179,00
107.16.320	MK 3 - M5 / M22 Gr. 2	179,00
107.16.412	MK 4 - M3 / M14 Gr. 1	190,00
107.16.420	MK 4 - M5 / M22 Gr. 2	230,00
107.16.436	MK 4 - M14/M36Gr. 3	350,00



### Reduzierhülse für Werkzeuge mit Morsekegel DIN 2185

Reduction sleeves for tools with Morse taper shanks DIN 2185

Douille de réductions pour outils avec cône morse DIN 2185

DIN 228-1 B

$\nabla \leq 0,01$

Bestell-Nr. Order no. / Référence	Abmessung Size / Dimension	Euro
107.07.21	MK 2 - MK 1 - 92	7,00
107.07.32	MK 3 - MK 2 - 112	8,00
107.07.42	MK 4 - MK 2 - 124	11,00
107.07.43	MK 4 - MK 3 - 140	12,00
107.07.53	MK 5 - MK 3 - 156	21,00
107.07.54	MK 5 - MK 4 - 171	21,00
107.07.64	MK 6 - MK 4 - 218	53,00
107.07.65	MK 6 - MK 5 - 218	53,00



Внимание! Данный прайс-лист для европейского рынка.

Цены в РФ значительно отличаются от цен, указанных в данном документе!

Для получения актуальной стоимости, обращайтесь по контактам, указанным ниже.

kemmler@kemmler.su  
www.kemmler.su

## Werkzeugaufnahmen MK DIN 228-1 A und DIN 228-1 B

Toolholders MT DIN 228-1 A and DIN 228-1 B

Porte-outils CM DIN 228-1 A et DIN 228-1 B



### Bohrfutteraufnahmen DIN 238

Drill chuck adaptors DIN 238

Arbres pour mandrins de perçage  
DIN 238

DIN 228-1 B

$\nabla \leq 0,008$

Bestell-Nr. Order no. / Référence	Abmessung Size / Dimension	Euro
107.14.12.02	MK 2 - B12	8,00
107.14.12.03	MK 3 - B12	9,00
107.14.12.04	MK 4 - B12	10,00
107.14.02	MK 2 - B16	6,00
107.14.03	MK 3 - B16	7,00
107.14.04	MK 4 - B16	10,00



### Einschraubbare Austreiblappen

Drift tangs to screw in

Tenons à visser

Bestell-Nr. Order no. / Référence	Abmessung Size / Dimension	Euro
107.20.06	MK 1 / M6	12,00
107.20.10	MK 2 / M10	13,00
107.20.12	MK 3 / M12	15,00
107.20.16	MK 4 / M16	21,00
107.20.20	MK 5 / M20	30,00



### Austreiber DIN 317 für Werkzeugkegel DIN 228 B

Drill drifts DIN 317

for cones DIN 228 B

Chasse-cônes DIN 317

pour cônes DIN 228 B

Bestell-Nr. Order no. / Référence	Abmessung Size / Dimension	Euro
107.03.01	MK 1+2 L=140	5,00
107.03.03	MK 3 L=190	6,00
107.03.04	MK 4 L=225	10,00



### CNC-Bohrfutter

CNC-Drill chucks

Mandrins de perçage CNC

DIN 228-1 B

$\nabla \leq 0,03$

Bestell-Nr. Order no. / Référence	Abmessung Size / Dimension	Euro
107.15.313	MK 3 - 1,0 / 13 - 98	252,00
107.15.316	MK 3 - 2,5 / 16 - 103	258,00
107.15.413	MK 4 - 1,0 / 13 - 100	263,00
107.15.416	MK 4 - 2,5 / 16 - 105	268,00



Внимание! Данный прайс-лист для европейского рынка.  
Цены в РФ значительно отличаются от цен, указанных в данном документе!  
Для получения актуальной стоимости, обращайтесь по контактам, указанным ниже.



# Inhaltsverzeichnis

Index

Table de matières

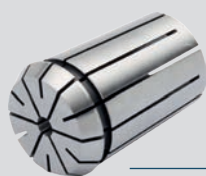

90



90



90



92

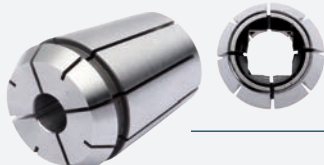

98



KPS System

102



HKS System

104



106



106



108



109



110



113



116



117



117



117



118

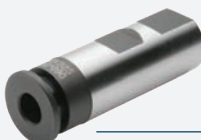

124



124



125



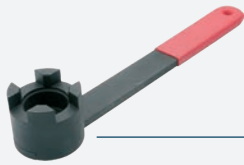

125



125



125

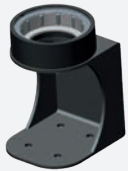

126



126



126



127

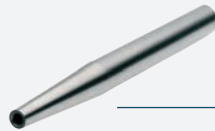

127



127



127



127



128



128



129



130

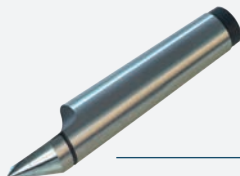

132

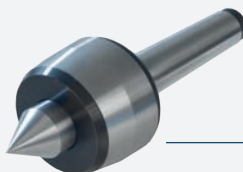

132



132



133



136



Внимание! Данный прайс-лист для европейского рынка.  
Цены в РФ значительно отличаются от цен, указанных в данном документе!  
Для получения актуальной стоимости, обращайтесь по контактам, указанным ниже.





## Spannzangen ≤ 0,015

Collets ≤ 0,015

Pincès de serrage ≤ 0,015



### Spannzangen DIN 6388 B (ISO 10897 B) System OZ

Collets DIN 6388 B (ISO 10897 B)  
OZ-system

Pincès de serrage DIN 6388 B  
(ISO 10897 B) système OZ

Bestell-Nr. Order no. / Référence	Abmessung Size / Dimension	Euro
415E - Ø (OZ 16)	2 – 3	16,00
415E - Ø	4 – 16	11,00
462E - Ø (OZ 25)	2	16,00
462E - Ø	3 – 25	12,00
467E - Ø (OZ 32)	3	28,00
467E - Ø	4 – 32	24,00

1 mm steigend  
1 mm steps  
1 mm croissant

↗ ≤ 0,015



### Spannzangen DIN 6499 B (ISO 15488 B) System ER

Collets DIN 6499 B (ISO 15488 B)  
ER-system

Pincès de serrage DIN 6499 B  
(ISO 15488 B) système ER

Bestell-Nr. Order no. / Référence	Abmessung Size / Dimension	Euro
4008E - Ø (ER11)*	1 – 1,5	14,00
4008E - Ø*	2 – 7	11,00
426E - Ø (ER 16)	1	15,00
426E - Ø	2 – 10	10,00
428E - Ø (ER 20)	2 – 13	13,00
430E - Ø (ER 25)	2	15,00
430E - Ø	3 – 16	11,00
470E - Ø (ER 32)	2	17,00
470E - Ø	3 – 20	12,00
472E - Ø (ER 40)	3	16,00
472E - Ø	4 – 26	14,00

1 mm steigend \*0,5 mm steigend  
1 mm steps \*0,5 mm steps  
1 mm croissant \*0,5 mm croissant

↗ ≤ 0,015



### Spannzangensätze im Holzsockel

Collet sets in wooden sockets

Jeux de pincès dans socles en bois

Bestell-Nr. Order no. / Référence	Abmessung Size / Dimension	Euro
415E - S	415 E (OZ 16; 15 tlg.) 2-3-4-5-6-7-8-9-10-11-12-13-14-15-16	168,00
462E - S	462 E (OZ 25; 15 tlg.) 4-5-6-7-8-9-10-11-12-14-16-18-20-22-25	174,00
467E - S	467 E (OZ 32; 16 tlg.) 5-6-7-8-10-12-14-16-18-20-22-24-25-28-30-32	370,00
4008E - S	4008 E (ER 11; 13 tlg.) 1-1,5-2-2,5-3-3,5-4-4,5-5-5,5-6-6,5-7	147,00
426E - S	426 E (ER 16; 10 tlg.) 1-2-3-4-5-6-7-8-9-10	100,00
428E - S	428 E (ER 20; 12 tlg.) 2-3-4-5-6-7-8-9-10-11-12-13	152,00
430E - S	430 E (ER 25; 15 tlg.) 2-3-4-5-6-7-8-9-10-11-12-13-14-15-16	162,00
470E - S	470 E (ER 32; 18 tlg.) 3-4-5-6-7-8-9-10-11-12-13-14-15-16-17-18-19-20	208,00
472E - S	472 E (ER 40; 23 tlg.) 4-5-6-7-8-9-10-11-12-13-14-15-16-17-18-19-20-21-22-23-24-25-26	314,00

↗ ≤ 0,015

Внимание! Данный прайс-лист для европейского рынка.

Цены в РФ значительно отличаются от цен, указанных в данном документе!

Для получения актуальной стоимости, обращайтесь по контактам, указанным ниже.

kemmler@kemmler.su  
www.kemmler.su



## Spannzangen ≤ 0,005 UP

Collets ≤ 0,005 UP

Pincettes de serrage ≤ 0,005 UP



### Präzisionsspannzangen DIN 6388 B (ISO 10897 B) System OZ

Precision collets DIN 6388 B  
(ISO 10897 B) OZ-system  
Pincettes de serrage de précision  
DIN 6388 B (ISO 10897 B) système OZ

Bestell-Nr. Order no. / Référence	Abmessung Size / Dimension	Euro
415EP - Ø (OZ 16)	2 – 3	19,00
415EP - Ø	4 – 16	17,00
462EP - Ø (OZ 25)	2	23,00
462EP - Ø	3 – 25	20,00
467EP - Ø (OZ 32)	3	37,00
467EP - Ø	4 – 32	35,00

1 mm steigend  
1 mm steps  
1 mm croissant

↗ ≤ 0,005



### Präzisionsspannzangen DIN 6499 B (ISO 15488 B) System ER

Precision collets DIN 6499 B  
(ISO 15488 B) ER-system  
Pincettes de serrage de précision  
DIN 6499 B (ISO 15488 B)  
système ER

Bestell-Nr. Order no. / Référence	Abmessung Size / Dimension	Euro
4008EP - Ø (ER11)*	1 – 1,5	24,00
4008EP - Ø*	2 – 7	22,00
426EP - Ø (ER 16)	1	25,00
426EP - Ø	2 – 10	23,00
428EP - Ø (ER 20)	2 – 13	23,00
430EP - Ø (ER 25)	2	27,00
430EP - Ø	3 – 16	25,00
470EP - Ø (ER 32)	2	29,00
470EP - Ø	3 – 20	27,00
472EP - Ø (ER 40)	3	39,00
472EP - Ø	4 – 26	37,00

1 mm steigend  
1 mm steps  
1 mm croissant

\*0,5 mm steigend  
\*0,5 mm steps  
\*0,5 mm croissant

↗ ≤ 0,005



### Präzisionsspannzangensätze im Holzsockel

Precision collet sets in wooden sockets  
Jeux de pincettes de précision dans socles en bois

Bestell-Nr. Order no. / Référence	Abmessung Size / Dimension	Euro
415EP - S	415 E (OZ 16; 15 tlg.) 2-3-4-5-6-7-8-9-10-11-12-13-14-15-16	257,00
462EP - S	462 E (OZ 25; 15 tlg.) 4-5-6-7-8-9-10-11-12-14-16-18-20-22-25	300,00
467EP - S	467 E (OZ 32; 16 tlg.) 5-6-7-8-10-12-14-16-18-20-22-24-25-28-30-32	555,00
4008EP - S	4008 E (ER 11; 13 tlg.) 1-1,5-2-2,5-3-3,5-4-4,5-5-5,5-6-6,5-7	290,00
426EP - S	426 E (ER 16; 10 tlg.) 1-2-3-4-5-6-7-8-9-10	232,00
428EP - S	428 E (ER 20; 12 tlg.) 2-3-4-5-6-7-8-9-10-11-12-13	276,00
430EP - S	430 E (ER 25; 15 tlg.) 2-3-4-5-6-7-8-9-10-11-12-13-14-15-16	377,00
470EP - S	470 E (ER 32; 18 tlg.) 3-4-5-6-7-8-9-10-11-12-13-14-15-16-17-18-19-20	486,00
472EP - S	472 E (ER 40; 23 tlg.) 4-5-6-7-8-9-10-11-12-13-14-15-16-17-18-19-20-21-22-23-24-25-26	851,00

↗ ≤ 0,005

Внимание! Данный прайс-лист для европейского рынка.  
Цены в РФ значительно отличаются от цен, указанных в данном документе!  
Для получения актуальной стоимости, обращайтесь по контактам, указанным ниже.

kemmler@kemmler.su  
www.kemmler.su

KEMMLER





## Spannzangensätze im Holzkasten

Collet sets in wooden boxes

Jeux de pinces dans coffrets en bois



### Spannzangensätze im Holzkasten

Collet sets in wooden boxes

Jeux de pinces dans coffrets en bois

↗ ≤ 0,015

Bestell-Nr. Order no. / Référence	Abmessung Size / Dimension	Euro
701.415.1	415E (OZ 16; 15 St.) 2-3-4-5-6-7-8-9-10-11-12-13-14-15-16	208,00
701.462.1	462E (OZ 25; 15 St.) 4-5-6-7-8-9-10-11-12-14-16-18-20-22-25	214,00
701.467.1	467E (OZ 32; 16 St.) 5-6-7-8-10-12-14-16-18-20-22-24-25-28-30-32	410,00
701.4008.1	4008E (ER 11; 13 St.) 1-1,5-2-2,5-3-3,5-4-4,5-5-5,5-6-6,5-7	183,00
701.426.1	426E (ER 16; 10 St.) 1-2-3-4-5-6-7-8-9-10	140,00
701.428.1	428E (ER 20; 12 St.) 2-3-4-5-6-7-8-9-10-11-12-13	192,00
701.430.1	430E (ER 25; 15 St.) 2-3-4-5-6-7-8-9-10-11-12-13-14-15-16	202,00
701.470.1	470E (ER 32; 15 St.) 3-4-5-6-7-8-9-10-11-12-14-15-16-18-20	214,00
701.472.1	472E (ER 40; 16 St.) 4-5-6-7-8-9-10-11-12-14-16-18-20-22-24-26	259,00



### Präzisionsspannzangensätze im Holzkasten

Precision collet sets in wooden boxes

Jeux de pinces de précision dans coffrets en bois

↗ ≤ 0,005

Bestell-Nr. Order no. / Référence	Abmessung Size / Dimension	Euro
701.415P.1	415E (OZ 16; 15 St.) 2-3-4-5-6-7-8-9-10-11-12-13-14-15-16	297,00
701.462P.1	462E (OZ 25; 15 St.) 4-5-6-7-8-9-10-11-12-14-16-18-20-22-25	340,00
701.467P.1	467E (OZ 32; 16 St.) 5-6-7-8-10-12-14-16-18-20-22-24-25-28-30-32	595,00
701.4008P.1	4008E (ER 11; 13 St.) 1-1,5-2-2,5-3-3,5-4-4,5-5-5,5-6-6,5-7	290,00
701.426P.1	426E (ER 16; 10 St.) 1-2-3-4-5-6-7-8-9-10	232,00
701.428P.1	428E (ER 20; 12 St.) 2-3-4-5-6-7-8-9-10-11-12-13	276,00
701.430P.1	430E (ER 25; 15 St.) 2-3-4-5-6-7-8-9-10-11-12-13-14-15-16	377,00
701.470P.1	470E (ER 32; 15 St.) 3-4-5-6-7-8-9-10-11-12-14-15-16-18-20	405,00
701.472P.1	472E (ER 40; 16 St.) 4-5-6-7-8-9-10-11-12-14-16-18-20-22-24-26	592,00



Внимание! Данный прайс-лист для европейского рынка.

Цены в РФ значительно отличаются от цен, указанных в данном документе!

Для получения актуальной стоимости, обращайтесь по контактам, указанным ниже.

kemmler@kemmler.su

www.kemmler.su

## Spannzangen

Collets

Pinces de serrage



**Holzkästen, leer**  
Wooden boxes, empty  
Coffrets en bois, vides

Bestell-Nr. Order no. / Réf.	Abmessung Size / Dimension	Euro
701.07	Gr. 7 (ER 11)	40,00
701.10	Gr. 10 (ER 16)	40,00
701.13	Gr. 13 (ER 20)	40,00
701.16	Gr. 16 (ER 25 / OZ 16)	40,00
701.20.25	Gr. 20 / 25 (ER 32 / OZ 25)	40,00
701.26.32	Gr. 26 / 32 (ER 40 / OZ 32)	40,00



**Holzsockel, leer**  
Wooden sockets, empty  
Socles en bois, vides

Bestell-Nr. Order no. / Réf.	Abmessung Size / Dimension	Euro
701.07.1	Gr. 7 (ER 11)	14,00
701.10.1	Gr. 10 (ER 16)	14,00
701.13.1	Gr. 13 (ER 20)	14,00
701.16.1	Gr. 16 (ER 25 / OZ 16)	14,00
701.20.25.1	Gr. 20 / 25 (ER 32 / OZ 25)	14,00
701.26.32.1	Gr. 26 / 32 (ER 40/OZ 32)	14,00



Внимание! Данный прайс-лист для европейского рынка.  
Цены в РФ значительно отличаются от цен, указанных в данном документе!  
Для получения актуальной стоимости, обращайтесь по контактам, указанным ниже.



## Spannzangen mit Dichtstopfen für Innenkühlung

Collets with seals for inner coolant supply

Pincettes de serrage avec joint d'étanchéité pour AC



### Spannzangen mit Abdichtung für IK DIN 6499 B (ISO 15488 B) System ER

Collets sealed with seal for IC DIN 6499 B (ISO 15488 B) ER-system

Pincettes de serrage avec joint d'étanchéité pour AC DIN 6499 B (ISO 15488 B) système ER

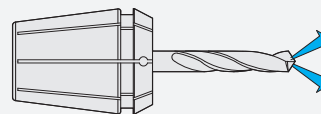

↗ ≤0,015

1 mm steigend  
1 mm steps  
1 mm croissant

Bestell-Nr. Order no. / Référence	Abmessung Size / Dimension	Euro
426EA - Ø (ER 16)	3 - 10	36,00
428EA - Ø (ER 20)	3 - 13	38,00
430EA - Ø (ER 25)	3 - 16	40,00
470EA - Ø (ER 32)	3 - 20	44,00
472EA - Ø (ER 40)	3 - 26	51,00

**Hinweis:** Nur das Nennmaß d kann gespannt werden, mit Dichtstopfen für Innenkühlung (einsetzbar bis 21 bar)  
**Note:** Only nominal size d can be clamped with sealing plug for internal cooling (applicable up to 21 bar)  
**Observation:** Seule la dimension nominale d peut être tendu avec des bouchons d'étanchéité pour le refroidissement interne (peut être utilisé jusqu'à 21 bar)



### Spannzangensätze im Holzsockel mit Abdichtung für IK DIN 6499 B (ISO 15488 B) System ER

Collet sets in wooden sockets sealed with seal for IC DIN 6499 B (ISO 15488 B) ER-system

Jeux de pincettes dans socles en bois avec joint d'étanchéité pour AC DIN 6499 B (ISO 15488 B) système ER

Bestell-Nr. Order no. / Référence	Abmessung Size / Dimension	Euro
426EA-S	426E (ER 16; 8 St.) 3-4-5-6-7-8-9-10	288,00
428EA-S	428E (ER 20; 11 St.) 3-4-5-6-7-8-9-10-11-12-13	418,00
430EA-S	430E (ER 25; 14 St.) 3-4-5-6-7-8-9-10-11-12-13-14-15-16	560,00
470EA-S	470E (ER 32; 15 St.) 3-4-5-6-7-8-9-10-11-12-14-15-16-18-20	660,00
472EA-S	472E (ER 40; 16 St.) 4-5-6-7-8-9-10-11-12-14-16-18-20-22-24-26	816,00



### Spannzangensätze im Holzkasten mit Abdichtung für IK DIN 6499 B (ISO 15488 B) System ER

Collet sets in wooden boxes collets sealed with seal for IC DIN 6499 B (ISO 15488 B) ER-system

Jeux de pincettes dans coffret en bois avec joint d'étanchéité pour AC DIN 6499 B (ISO 15488 B) système ER

Bestell-Nr. Order no. / Référence	Abmessung Size / Dimension	Euro
701.426EA.1	426E (ER 16; 8 St.) 3-4-5-6-7-8-9-10	288,00
701.428EA.1	428E (ER 20; 11 St.) 3-4-5-6-7-8-9-10-11-12-13	418,00
701.430EA.1	430E (ER 25; 14 St.) 3-4-5-6-7-8-9-10-11-12-13-14-15-16	560,00
701.470EA.1	470E (ER 32; 15 St.) 3-4-5-6-7-8-9-10-11-12-14-15-16-18-20	660,00
701.472EA.1	472E (ER 40; 16 St.) 4-5-6-7-8-9-10-11-12-14-16-18-20-22-24-26	816,00

Внимание! Данный прайс-лист для европейского рынка.

Цены в РФ значительно отличаются от цен, указанных в данном документе!

Для получения актуальной стоимости, обращайтесь по контактам, указанным ниже.

kemmler@kemmler.su  
www.kemmler.su



## Spannzangen abgedichtet für Hochdruckkühlung bis 120 bar

Collets with seals for high pressure cooling until 120 bar

Pincettes de serrage, étanche pour arrosage de haute pression 120 bar

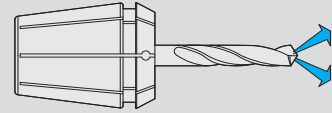

### Spannzangen für Hochdruckkühlung 120 bar abgedichtet mit IK DIN 6499 B (ISO 15488 B) System ER

Collets sealed for high pressure cooling 120 bar with IC DIN 6499 B (ISO 15488 B) ER-system

Pincettes de serrage, étanche pour arrosage de haute pression 120 bar avec arrosage centrale DIN 6499 B (ISO 15488 B) système ER

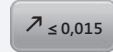

1 mm steigend  
1 mm steps  
1 mm croissant

Bestell-Nr. Order no. / Référence	Abmessung Size / Dimension	Euro
426EH - Ø (ER 16)	3 - 10	42,00
428EH - Ø (ER 20)	3 - 13	44,00
430EH - Ø (ER 25)	3 - 16	46,00
470EH - Ø (ER 32)	3 - 20	49,00
472EH - Ø (ER 40)	3 - 26	58,00

**Hinweis:** Nur das Nennmaß d kann gespannt werden  
**Note:** Only nominal size d can be clamped  
**Observation:** Seule la dimension nominale d peut être tendu

### Spannzangen im Holzsockel für Hochdruckkühlung 120 bar abgedichtet mit IK DIN 6499 B (ISO 15488 B) System ER



Collets sealed for high pressure cooling 120 bar in wooden sockets with IC DIN 6499 B (ISO 15488 B) ER-system

Pincettes de serrage, étanche pour arrosage de haute pression 120 bar dans socles en bois avec arrosage centrale DIN 6499 B (ISO 15488 B) système ER

Bestell-Nr. Order no. / Référence	Abmessung Size / Dimension	Euro
426EH-S	426E (ER 16; 8 St.) 3-4-5-6-7-8-9-10	336,00
428EH-S	428E (ER 20; 11 St.) 3-4-5-6-7-8-9-10-11-12-13	484,00
430EH-S	430E (ER 25; 14 St.) 3-4-5-6-7-8-9-10-11-12-13-14-15-16	644,00
470EH-S	470E (ER 32; 15 St.) 3-4-5-6-7-8-9-10-11-12-14-15-16-18-20	735,00
472EH-S	472E (ER 40; 16 St.) 4-5-6-7-8-9-10-11-12-14-16-18-20-22-24-26	928,00



### Spannzangen im Holzkasten für Hochdruckkühlung 120 bar abgedichtet mit IK DIN 6499 B (ISO 15488 B) System ER

Collets sealed for high pressure cooling 120 bar in wooden boxes with IC DIN 6499 B (ISO 15488 B) ER-system

Pincettes de serrage, étanche pour arrosage de haute pression 120 bar dans coffret en bois avec arrosage centrale DIN 6499 B (ISO 15488 B) système ER

Bestell-Nr. Order no. / Référence	Abmessung Size / Dimension	Euro
701.426EH.1	426E (ER 16; 8 St.) 3-4-5-6-7-8-9-10	336,00
701.428EH.1	428E (ER 20; 11 St.) 3-4-5-6-7-8-9-10-11-12-13	484,00
701.430EH.1	430E (ER 25; 14 St.) 3-4-5-6-7-8-9-10-11-12-13-14-15-16	644,00
701.470EH.1	470E (ER 32; 15 St.) 3-4-5-6-7-8-9-10-11-12-14-15-16-18-20	735,00
701.472EH.1	472E (ER 40; 16 St.) 4-5-6-7-8-9-10-11-12-14-16-18-20-22-24-26	928,00

**Внимание!** Данный прайс-лист для европейского рынка.  
Цены в РФ значительно отличаются от цен, указанных в данном документе!  
Для получения актуальной стоимости, обращайтесь по контактам, указанным ниже.





## Spannzangen mit Dichtstopfen und Kühlkanalbohrungen

Collets with seals and cooling channels

Pincettes de serrage avec canaux d'arrosage



### Spannzangen mit Kühlkanalbohrungen DIN 6499 B (ISO 15488 B) System ER

Collets with cooling channels

DIN 6499 B (ISO 15488 B) ER-system

Pincettes de serrage avec canaux d'arrosage

DIN 6499 B (ISO 15488 B) système ER



↗ ≤ 0,015

1 mm steigend  
1 mm steps  
1 mm croissant

Bestell-Nr. Order no. / Référence	Abmessung Size / Dimension	Euro
426EC - Ø (ER 16)	3 - 7	38,00
428EC - Ø (ER 20)	4 - 9	40,00
430EC - Ø (ER 25)	3 - 14	42,00
470EC - Ø (ER 32)	3 - 20	46,00
472EC - Ø (ER 40)	4 - 26	53,00

**Hinweis:**

**Note:**

**Observation:**

Nur das Nennmaß d kann gespannt werden, mit Kühlkanälen

Only nominal size d can be clamped, with cooling channels

Seule la dimension nominale d peut être tendu, avec canaux d'arrosage



### Spannzangensätze im Holzsockel mit Kühlkanalbohrungen DIN 6499B (ISO 15488 B) System ER

Collet sets in wooden sockets with cooling channels

DIN 6499 B (ISO 15488 B) ER-system

Jeux de pincettes dans socles en bois avec canaux d'arrosage DIN

6499 B (ISO 15488 B) système ER

Bestell-Nr. Order no. / Référence	Abmessung Size / Dimension	Euro
426EC-S	426E (ER 16; 5 St.) 3-4-5-6-7	190,00
428EC-S	428E (ER 20; 6 St.) 4-5-6-7-8-9	240,00
430EC-S	430E (ER 25; 12 St.) 3-4-5-6-7-8-9-10-11-12-13-14	504,00
470EC-S	470E (ER 32; 15 St.) 3-4-5-6-7-8-9-10-11-12-14-15-16-18-20	690,00
472EC-S	472E (ER 40; 16 St.) 4-5-6-7-8-9-10-11-12-14-16-18-20-22-24-26	848,00



### Spannzangensätze im Holzkasten mit Kühlkanalbohrungen DIN 6499 B (ISO 15488 B) System ER

Collet sets in wooden boxes with cooling channels

DIN 6499 B (ISO 15488 B) ER-system

Jeux de pincettes dans coffrets en bois avec canaux d'arrosage

DIN 6499 B (ISO 15488 B) système ER

↗ ≤ 0,015

Bestell-Nr. Order no. / Référence	Abmessung Size / Dimension	Euro
701.426EC.1	426E (ER 16; 5 St.) 3-4-5-6-7	190,00
701.428EC.1	428E (ER 20; 6 St.) 4-5-6-7-8-9	240,00
701.430EC.1	430E (ER 25; 12 St.) 3-4-5-6-7-8-9-10-11-12-13-14	504,00
701.470EC.1	470E (ER 32; 15 St.) 3-4-5-6-7-8-9-10-11-12-14-15-16-18-20	690,00
701.472EC.1	472E (ER 40; 16 St.) 4-5-6-7-8-9-10-11-12-14-16-18-20-22-24-26	848,00

Внимание! Данный прайс-лист для европейского рынка.

Цены в РФ значительно отличаются от цен, указанных в данном документе!

Для получения актуальной стоимости, обращайтесь по контактам, указанным ниже.

kemmler@kemmler.su

www.kemmler.su

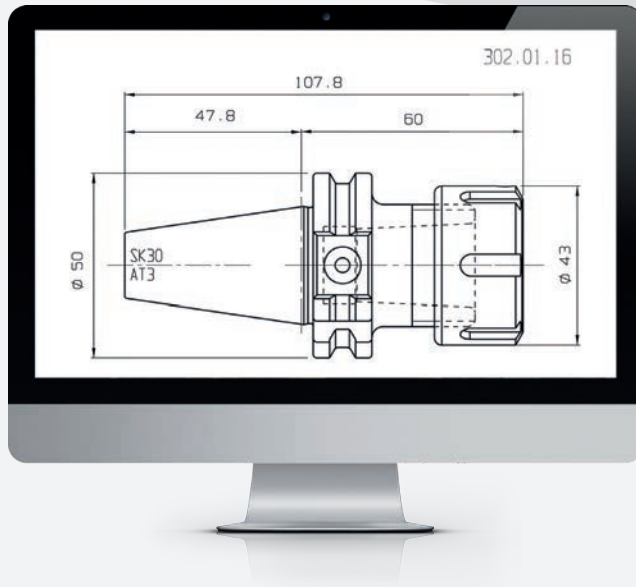

Technische Datenblätter, STEP-/STL-Modelle für die Simulation der NC-Programme und DXF-Zeichnungen zur Erstellung des Einrichteblattes stehen Online zur Verfügung.

*Technical data sheets, STEP / STL models for the simulation of NC programs and DXF drawings to create the tooling sheet are online available.*

Fiches techniques, STEP/STL modèles techniques pour la simulation de programmes CN et dessins DXF pour créer la feuille d'installation sont disponible online.

Sie können unsere Kataloge entweder direkt im Browser betrachten oder Sie auf Ihren PC, Smartphone oder Tablet herunterladen (PDF-Reader notwendig).

*You can view our catalogues either directly in the browser or download to your PC, smartphone or tablet (PDF reader required).*

Vous pouvez consulter nos catalogues directement dans le navigateur ou télécharger sur votre PC, smartphone ou tablet (lecteur PDF requis).

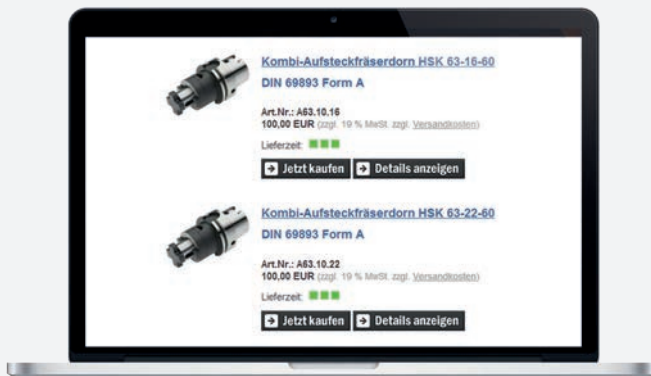

Auf unserer Internetseite können Sie auch die Lagerverfügbarkeit prüfen.

*On our website you can also check the stock availability.*

Sur notre site internet vous pouvez également vérifier la disponibilité du stock.



**Внимание! Данный прайс-лист для европейского рынка.**  
Цены в РФ значительно отличаются от цен, указанных в данном документе!  
Для получения актуальной стоимости, обращайтесь по контактам, указанным ниже.



## Gewindebohrer Spannzangen

Tap collets

Pinces de serrage pour tarauds



### Spannzangen DIN 6499 A (ISO 15488 A) System ER mit Innenvierkant für Gewindebohrer

Collets DIN 6499 A (ISO 15488 A)  
ER-system with square locking drive for tapping drills

Pinces de serrage DIN 6499 A (ISO 15488 A) système ER avec carré d'entraînement pour tarauds

Bestell-Nr. Order no. / Référence	Abmessung Size / Dimension	Euro
426G-3527	ER 16 - 3,5 × 2,7	31,00
426G-43	ER 16 - 4 × 3	31,00
426G-4534	ER 16 - 4,5 × 3,4	31,00
426G-649	ER 16 - 6 × 4,9	31,00
426G-755	ER 16 - 7 × 5,5	31,00
426G-862	ER 16 - 8 × 6,2	31,00
428G-3527	ER 20 - 3,5 × 2,7	32,00
428G-43	ER 20 - 4 × 3	32,00
428G-4534	ER 20 - 4,5 × 3,4	32,00
428G-649	ER 20 - 6 × 4,9	32,00
428G-755	ER 20 - 7 × 5,5	32,00
428G-862	ER 20 - 8 × 6,2	32,00
428G-97	ER 20 - 9 × 7	32,00
428G-108	ER 20 - 10 × 8	32,00
430G-3527	ER 25 - 3,5 × 2,7	32,00
430G-43	ER 25 - 4 × 3	32,00
430G-4534	ER 25 - 4,5 × 3,4	32,00
430G-649	ER 25 - 6 × 4,9	32,00
430G-755	ER 25 - 7 × 5,5	32,00
430G-862	ER 25 - 8 × 6,2	32,00
430G-97	ER 25 - 9 × 7	32,00
430G-108	ER 25 - 10 × 8	32,00
430G-119	ER 25 - 11 × 9	32,00
430G-129	ER 25 - 12 × 9	32,00



### Spannzangen DIN 6499 A (ISO 15488 A) System ER mit Innenvierkant für Gewindebohrer

Collets DIN 6499 A (ISO 15488 A)  
ER-system with square locking drive for tapping drills

Pinces de serrage DIN 6499 A (ISO 15488 A) système ER avec carré d'entraînement pour tarauds

Bestell-Nr. Order no. / Référence	Abmessung Size / Dimension	Euro
470G-4534	ER 32 - 4,5 × 3,4	33,00
470G-649	ER 32 - 6 × 4,9	33,00
470G-755	ER 32 - 7 × 5,5	33,00
470G-862	ER 32 - 8 × 6,2	33,00
470G-97	ER 32 - 9 × 7	33,00
470G-108	ER 32 - 10 × 8	33,00
470G-119	ER 32 - 11 × 9	33,00
470G-129	ER 32 - 12 × 9	33,00
470G-1411	ER 32 - 14 × 11	33,00
470G-1612	ER 32 - 16 × 12	33,00
472G-649	ER 40 - 6 × 4,9	34,00
472G-755	ER 40 - 7 × 5,5	34,00
472G-862	ER 40 - 8 × 6,2	34,00
472G-97	ER 40 - 9 × 7	34,00
472G-108	ER 40 - 10 × 8	34,00
472G-119	ER 40 - 11 × 9	34,00
472G-129	ER 40 - 12 × 9	34,00
472G-1411	ER 40 - 14 × 11	34,00
472G-1612	ER 40 - 16 × 12	34,00
472G-18145	ER 40 - 18 × 14,5	34,00
472G-2016	ER 40 - 20 × 16	34,00



Внимание! Данный прайс-лист для европейского рынка.

Цены в РФ значительно отличаются от цен, указанных в данном документе!

Для получения актуальной стоимости, обращайтесь по контактам, указанным ниже.

kemmler@kemmler.su  
www.kemmler.su

## Spannzangensätze

Collet sets

Jeux de pinces de serrage



### Spannzangensätze im Holzsockel DIN 6499 A (ISO 15488 A) System ER mit Innenvierkant für Gewindebohrer

Collet sets in wooden sockets DIN 6499  
A (ISO 15488 A) ER-system with square  
locking drive for tapping drills  
Jeux de pinces dans socles en bois DIN  
6499 A (ISO 15488 A) système ER avec  
carré d'entraînement pour tarauds

Bestell-Nr. Order no. / Référence	Abmessung Size / Dimension	Euro
426G-S	426E (ER 16; 6 St.) 3,5×2,7 - 4×3 - 4,5×3,4 - 6×4,9 - 7×5,5 - 8×6,2	186,00
428G-S	428E (ER 20; 8 St.) 3,5×2,7 - 4×3 - 4,5×3,4 - 6×4,9 - 7×5,5 - 8×6,2 - 9×7 - 10×8	256,00
430G-S	430E (ER 25; 10 St.) 3,5×2,7 - 4×3 - 4,5×3,4 - 6×4,9 - 7×5,5 - 8×6,2 - 9×7 - 10×8 - 11×9 - 12×9	320,00
470G-S	470E (ER 32; 10 St.) 4,5×3,4 - 6×4,9 - 7×5,5 - 8×6,2 - 9×7 - 10×8 - 11×9 - 12×9 - 14×11 - 16×12	330,00
472G-S	472E (ER 40; 11 St.) 6×4,9 - 7×5,5 - 8×6,2 - 9×7 - 10×8 - 11×9 - 12×9 - 14×11 - 16×12 - 18×14,5 - 20×16	374,00



### Spannzangensätze im Holzkasten DIN 6499 A (ISO 15488 A) System ER mit Innenvierkant für Gewindebohrer

Collet sets in wooden boxes DIN 6499 A  
(ISO 15488 A) ER-system with square  
locking drive for tapping drills  
Jeux de pinces dans coffrets en bois DIN  
6499 A (ISO 15488 A) système ER avec  
carré d'entraînement pour tarauds

Bestell-Nr. Order no. / Référence	Abmessung Size / Dimension	Euro
701.426G.1	426E (ER 16; 6 St.) 3,5×2,7 - 4×3 - 4,5×3,4 - 6×4,9 - 7×5,5 - 8×6,2	186,00
701.428G.1	428E (ER 20; 8 St.) 3,5×2,7 - 4×3 - 4,5×3,4 - 6×4,9 - 7×5,5 - 8×6,2 - 9×7 - 10×8	256,00
701.430G.1	430E (ER 25; 10 St.) 3,5×2,7 - 4×3 - 4,5×3,4 - 6×4,9 - 7×5,5 - 8×6,2 - 9×7 - 10×8 - 11×9 - 12×9	320,00
701.470G.1	470E (ER 32; 10 St.) 4,5×3,4 - 6×4,9 - 7×5,5 - 8×6,2 - 9×7 - 10×8 - 11×9 - 12×9 - 14×11 - 16×12	330,00
701.472G.1	472E (ER 40; 11 St.) 6×4,9 - 7×5,5 - 8×6,2 - 9×7 - 10×8 - 11×9 - 12×9 - 14×11 - 16×12 - 18×14,5 - 20×16	374,00



Внимание! Данный прайс-лист для европейского рынка.  
Цены в РФ значительно отличаются от цен, указанных в данном документе!  
Для получения актуальной стоимости, обращайтесь по контактам, указанным ниже.





## Гвиндебоhrer Spannзangen mit Dichtstopfen und Kuhkanalbohrungen

Tap collets with seals and cooling channels

Pinces de serrage pour tarauds avec canaux d'arrosage



### Spannзangen mit Kuhkanalbohrungen DIN 6499 A (ISO 15488 A) System ER mit Innenvierkant fur Gwindebohrer

Collets with cooling channels DIN 6499 A (ISO 15488 A) ER-system with square locking drive for tapping drills

Pinces de serrage avec canaux d'arrosage DIN 6499 A (ISO 15488 A) systeme ER avec carre d'entranement pour tarauds

Bestell-Nr. Order no. / Reference	Abmessung Size / Dimension	Euro
426GC-3527	ER 16 - 3,5 × 2,7	59,00
426GC-43	ER 16 - 4 × 3	59,00
426GC-4534	ER 16 - 4,5 × 3,4	59,00
426GC-649	ER 16 - 6 × 4,9	59,00
426GC-755	ER 16 - 7 × 5,5	59,00
426GC-862	ER 16 - 8 × 6,2	59,00
428GC-3527	ER 20 - 3,5 × 2,7	59,00
428GC-43	ER 20 - 4 × 3	59,00
428GC-4534	ER 20 - 4,5 × 3,4	59,00
428GC-649	ER 20 - 6 × 4,9	59,00
428GC-755	ER 20 - 7 × 5,5	59,00
428GC-862	ER 20 - 8 × 6,2	59,00
428GC-97	ER 20 - 9 × 7	59,00
428GC-108	ER 20 - 10 × 8	59,00
430GC-3527	ER 25 - 3,5 × 2,7	59,00
430GC-43	ER 25 - 4 × 3	59,00
430GC-4534	ER 25 - 4,5 × 3,4	59,00
430GC-649	ER 25 - 6 × 4,9	59,00
430GC-755	ER 25 - 7 × 5,5	59,00
430GC-862	ER 25 - 8 × 6,2	59,00
430GC-97	ER 25 - 9 × 7	59,00
430GC-108	ER 25 - 10 × 8	59,00
430GC-119	ER 25 - 11 × 9	59,00
430GC-129	ER 25 - 12 × 9	59,00



### Spanнзangen mit Kuhkanalbohrungen DIN 6499 A (ISO 15488 A) System ER mit Innenvierkant fur Gwindebohrer

Collets with cooling channels DIN 6499 A (ISO 15488 A) ER-system with square locking drive for tapping drills

Pinces de serrage avec canaux d'arrosage DIN 6499 A (ISO 15488 A) systeme ER avec carre d'entranement pour tarauds

Bestell-Nr. Order no. / Reference	Abmessung Size / Dimension	Euro
470GC-4534	ER 32 - 4,5 × 3,4	59,00
470GC-649	ER 32 - 6 × 4,9	59,00
470GC-755	ER 32 - 7 × 5,5	59,00
470GC-862	ER 32 - 8 × 6,2	59,00
470GC-97	ER 32 - 9 × 7	59,00
470GC-108	ER 32 - 10 × 8	59,00
470GC-119	ER 32 - 11 × 9	59,00
470GC-129	ER 32 - 12 × 9	59,00
470GC-1411	ER 32 - 14 × 11	59,00
470GC-1612	ER 32 - 16 × 12	59,00
472GC-649	ER 40 - 6 × 4,9	69,00
472GC-755	ER 40 - 7 × 5,5	69,00
472GC-862	ER 40 - 8 × 6,2	69,00
472GC-97	ER 40 - 9 × 7	69,00
472GC-108	ER 40 - 10 × 8	69,00
472GC-119	ER 40 - 11 × 9	69,00
472GC-129	ER 40 - 12 × 9	69,00
472GC-1411	ER 40 - 14 × 11	69,00
472GC-1612	ER 40 - 16 × 12	69,00
472GC-18145	ER 40 - 18 × 14,5	69,00
472GC-2016	ER 40 - 20 × 16	69,00

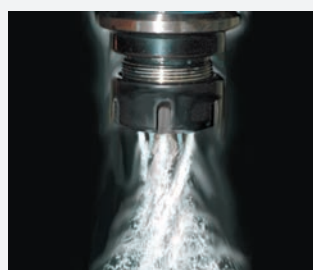

Внимание! Данный прайс-лист для европейского рынка.

Цены в РФ значительно отличаются от цен, указанных в данном документе!

Для получения актуальной стоимости, обращайтесь по контактам, указанным ниже.

kemmler@kemmler.su  
www.kemmler.su

## Spannzangensätze

Collet sets

Jeux de pinces de serrage



### Spannzangensätze im Holzsockel mit Kühlkanalbohrungen DIN 6499 A (ISO 15488 A) System ER mit Innenvierkant für Gewindebohrer

Collets set with cooling channels in wooden sockets DIN 6499 A (ISO 15488 A) ER-system with square locking drive for tapping drills  
Jeux de pinces avec canaux d'arrosage en socles en bois DIN 6499 A (ISO 15488 A) système ER avec carré d'entraînement pour tarauds

Bestell-Nr. Order no. / Référence	Abmessung Size / Dimension	Euro
426GC-S	426E (ER 16   6 St.) 3,5×2,7 - 4×3 - 4,5×3,4 - 6×4,9 - 7×5,5 - 8×6,2	354,00
428GC-S	428E (ER 20   8 St.) 3,5×2,7 - 4×3 - 4,5×3,4 - 6×4,9 - 7×5,5 - 8×6,2 - 9×7 - 10×8	472,00
430GC-S	430E (ER 25   10 St.) 3,5×2,7 - 4×3 - 4,5×3,4 - 6×4,9 - 7×5,5 - 8×6,2 - 9×7 - 10×8 - 11×9 - 12×9	590,00
470GC-S	470E (ER 32   10 St.) 4,5×3,4 - 6×4,9 - 7×5,5 - 8×6,2 - 9×7 - 10×8 - 11×9 - 12×9 - 14×11 - 16×12	590,00
472GC-S	472E (ER 40   11 St.) 6×4,9 - 7×5,5 - 8×6,2 - 9×7 - 10×8 - 11×9 - 12×9 - 14×11 - 16×12 - 18×14,5 - 20×16	759,00



### Spannzangensätze im Holzkasten mit Kühlkanalbohrungen DIN 6499 A (ISO 15488 A) System ER mit Innenvierkant für Gewindebohrer

Collets set with cooling channels in wooden boxes DIN 6499 A (ISO 15488 A) ER-system with square locking drive for tapping drills  
Jeux de pinces avec canaux d'arrosage en coffrets en bois DIN 6499 A (ISO 15488 A) système ER avec carré d'entraînement pour tarauds

Bestell-Nr. Order no. / Référence	Abmessung Size / Dimension	Euro
701.426GC.1	426E (ER 16; 6 St.) 3,5×2,7 - 4×3 - 4,5×3,4 - 6×4,9 - 7×5,5 - 8×6,2	354,00
701.428GC.1	428E (ER 20; 8 St.) 3,5×2,7 - 4×3 - 4,5×3,4 - 6×4,9 - 7×5,5 - 8×6,2 - 9×7 - 10×8	472,00
701.430GC.1	430E (ER 25; 10 St.) 3,5×2,7 - 4×3 - 4,5×3,4 - 6×4,9 - 7×5,5 - 8×6,2 - 9×7 - 10×8 - 11×9 - 12×9	590,00
701.470GC.1	470E (ER 32; 10 St.) 4,5×3,4 - 6×4,9 - 7×5,5 - 8×6,2 - 9×7 - 10×8 - 11×9 - 12×9 - 14×11 - 16×12	590,00
701.472GC.1	472E (ER 40; 11 St.) 6×4,9 - 7×5,5 - 8×6,2 - 9×7 - 10×8 - 11×9 - 12×9 - 14×11 - 16×12 - 18×14,5 - 20×16	759,00



Внимание! Данный прайс-лист для европейского рынка.  
Цены в РФ значительно отличаются от цен, указанных в данном документе!  
Для получения актуальной стоимости, обращайтесь по контактам, указанным ниже.

kemmler@kemmler.su  
www.kemmler.su

KEMMLER

101



## System KPS

System KPS  
Système KPS



### Präzisionsspannzangen System KPS

Precision collets KPS-system  
Pinces de serrage de précision  
système KPS

Bestell-Nr. Order no. / Référence	Abmessung Size / Dimension	Euro
490EK - Ø (KPS 10)	1,0 – 5,5	42,00
	6,0 – 10,0	34,00

496EK - Ø (KPS 16)	4,0	51,00
	4,5 – 16,0	42,00

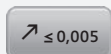

0,5 mm steigend  
0,5 mm steps  
0,5 mm croissant



### Montagehilfe System KPS

Collet extractor KPS-system  
Moyen d'assemblage système KPS

Bestell-Nr. Order no. / Référence	Abmessung Size / Dimension	Euro
490EK-183	KPS 10	15,00
496EK-183	KPS 16	19,00



### Einstellschraube für System KPS für innere Kühlmittelzufuhr

Setting screw for KPS-system for  
internal cooling  
Vis de réglage pour système KPS  
pour l'arrosage centrale

Bestell-Nr. Order no. / Référence	Abmessung Size / Dimension	Euro
490EK-184	KPS 10	9,00
496EK-184	KPS 16	12,00



### Spannmutter System KPS

Clamping nuts KPS-system  
Écrous de serrage système KPS

Bestell-Nr. Order no. / Référence	Abmessung Size / Dimension	Euro
490EK-181	KPS 10	27,00
496EK-181	KPS 16	30,00



### Spannschlüssel für Spannmutter System KPS

Wrenches for clamping nuts  
KPS-system  
Clés de serrage pour écrous  
de serrage système KPS

Bestell-Nr. Order no. / Référence	Abmessung Size / Dimension	Euro
490EK-182	KPS 10	83,00
496EK-182	KPS 16	96,00

8

## System KPS

System KPS  
Système KPS



### KPS Spannzangensätze im Holzsockel

KPS collet sets in wooden sockets

KPS jeux de pinces dans socles en bois

Bestell-Nr. Order no. / Référence	Abmessung Size / Dimension	Euro
490EK-S	490 EK (KPS 10   9 St.) 2-3-4-5-6-7-8-9-10	338,00
496EK-S	496 EK (KPS 16   13 St.) 4-5-6-7-8-9-10-11-12-13-14-15-16	555,00



Внимание! Данный прайс-лист для европейского рынка.  
Цены в РФ значительно отличаются от цен, указанных в данном документе!  
Для получения актуальной стоимости, обращайтесь по контактам, указанным ниже.

kemmler@kemmler.su  
www.kemmler.su

**KEMMLER**

**103**



## System HKS

System HKS  
Système HKS



### Reduzierungen für Hochleistungs-Kraftspannfutter

Reduction sleeves for High Performance Milling Chuck  
Douilles de réduction pour Mandrin à serrage à haute performance

Bestell-Nr. Order no. / Référence	Abmessung Size / Dimension	Euro
HKS20.060	20 - 6	21,00
HKS20.080	20 - 8	21,00
HKS20.100	20 - 10	21,00
HKS20.120	20 - 12	21,00
HKS20.140	20 - 14	21,00
HKS20.160	20 - 16	21,00
HKS32.060	32 - 6	24,00
HKS32.080	32 - 8	24,00
HKS32.100	32 - 10	24,00
HKS32.120	32 - 12	24,00
HKS32.140	32 - 14	24,00
HKS32.160	32 - 16	24,00
HKS32.180	32 - 18	24,00
HKS32.200	32 - 20	24,00
HKS32.250	32 - 25	24,00



### Hakenschlüssel für System HKS

Wrenches for HKS-system  
Clés à ergot pour système HKS

Bestell-Nr. Order no. / Référence	Abmessung Size / Dimension	Euro
64.182.20	HKS 20	11,00
64.182.32	HKS 32	12,00



### Auszieher für Reduzierungen System HKS

Extractor for reduction sleeves system HKS  
Extracteur pour douilles de réduction système HKS

Bestell-Nr. Order no. / Référence	Abmessung Size / Dimension	Euro
64.187.2032	HKS 20 / HKS 32	6,00



### Reduzierungen für Hochleistungs-Kraftspannfutter kühlmitteldicht

Reduction sleeves for High Performance Milling Chuck coolant proof  
Douilles de réduction pour Mandrin à serrage à haute performance, étanche

Bestell-Nr. Order no. / Référence	Abmessung Size / Dimension	Euro
HKS.RD20.030	20 - 3	95,00
HKS.RD20.040	20 - 4	95,00
HKS.RD20.050	20 - 5	95,00
HKS.RD20.060	20 - 6	72,00
HKS.RD20.080	20 - 8	72,00
HKS.RD20.100	20 - 10	72,00
HKS.RD20.120	20 - 12	72,00
HKS.RD20.140	20 - 14	72,00
HKS.RD20.160	20 - 16	72,00
HKS.RD32.030	32 - 3	111,00
HKS.RD32.040	32 - 4	111,00
HKS.RD32.050	32 - 5	111,00
HKS.RD32.060	32 - 6	100,00
HKS.RD32.080	32 - 8	100,00
HKS.RD32.100	32 - 10	100,00
HKS.RD32.120	32 - 12	100,00
HKS.RD32.140	32 - 14	100,00
HKS.RD32.160	32 - 16	100,00
HKS.RD32.180	32 - 18	100,00
HKS.RD32.200	32 - 20	100,00
HKS.RD32.250	32 - 25	100,00



### Einstellschraube für System HKS

Setting screw for system HKS  
Vis de réglage pour système HKS

Bestell-Nr. Order no. / Référence	Abmessung Size / Dimension	Euro
HKS20.184	HKS 20	27,00
HKS32.184	HKS 32	30,00

Внимание! Данный прайс-лист для европейского рынка.

Цены в РФ значительно отличаются от цен, указанных в данном документе!

Для получения актуальной стоимости, обращайтесь по контактам, указанным ниже.

kemmler@kemmler.su  
www.kemmler.su



## System HKS

System HKS  
Système HKS



**HKS Kraftspannfutter im Holzkasten mit Reduzierungen**  
HKS Milling chuck in wooden box with reduction bushes  
HKS mandrin de serrage dans coffret en bois avec douilles de réduction

Bestell-Nr. Order no. / Référence	Abmessung Size / Dimension	Euro
403.64.20.SR	(HKS20 ; 5 St.) 6-8-10-12-16	330,00
403.64.32.SR	(HKS32 ; 7 St.) 6-8-10-12-16-20-25	404,00
503.64.20.SR	(HKS20 ; 5 St.) 6-8-10-12-16	388,00
503.64.32.SR	(HKS32 ; 7 St.) 6-8-10-12-16-20-25	461,00
406.64.20.SR	(HKS20 ; 5 St.) 6-8-10-12-16	330,00
406.64.32.SR	(HKS32 ; 7 St.) 6-8-10-12-16-20-25	404,00
506.64.20.SR	(HKS20 ; 5 St.) 6-8-10-12-16	388,00
506.64.32.SR	(HKS32 ; 7 St.) 6-8-10-12-16-20-25	461,00
A63.64.20.SR	(HKS20 ; 5 St.) 6-8-10-12-16	430,00
A63.64.32.SR	(HKS32 ; 7 St.) 6-8-10-12-16-20-25	503,00
A100.64.20.SR	(HKS20 ; 5 St.) 6-8-10-12-16	503,00
A100.64.32.SR	(HKS32 ; 7 St.) 6-8-10-12-16-20-25	587,00



**HKS Kraftspannfutter im Holzkasten mit Reduzierungen, kühlmitteldicht**  
HKS Milling chuck in wooden box with reduction bushes, coolant proof  
HKS mandrin de serrage dans coffret en bois avec douilles de réduction, étanche

Bestell-Nr. Order no. / Référence	Abmessung Size / Dimension	Euro
403.64.20.SRD	(HKS20 RD; 5 St.) 6-8-10-12-16	585,00
403.64.32.SRD	(HKS32 RD; 7 St.) 6-8-10-12-16-20-25	925,00
503.64.20.SRD	(HKS20 RD; 5 St.) 6-8-10-12-16	643,00
503.64.32.SRD	(HKS32 RD; 7 St.) 6-8-10-12-16-20-25	993,00
406.64.20.SRD	(HKS20 RD; 5 St.) 6-8-10-12-16	585,00
406.64.32.SRD	(HKS32 RD; 7 St.) 6-8-10-12-16-20-25	925,00
506.64.20.SRD	(HKS20 RD; 5 St.) 6-8-10-12-16	643,00
506.64.32.SRD	(HKS32 RD; 7 St.) 6-8-10-12-16-20-25	993,00
A63.64.20.SRD	(HKS20 RD; 5 St.) 6-8-10-12-16	685,00
A63.64.32.SRD	(HKS32 RD; 7 St.) 6-8-10-12-16-20-25	1035,00
A100.64.20.SRD	(HKS20 RD; 5 St.) 6-8-10-12-16	758,00
A100.64.32.SRD	(HKS32 RD; 7 St.) 6-8-10-12-16-20-25	1119,00

Внимание! Данный прайс-лист для европейского рынка.  
Цены в РФ значительно отличаются от цен, указанных в данном документе!  
Для получения актуальной стоимости, обращайтесь по контактам, указанным ниже.

kemmler@kemmler.su  
www.kemmler.su

KEMMLER

105





**Zubehör**  
Accessories  
Accessoires

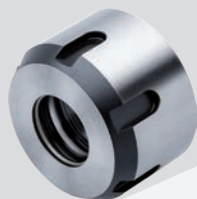

**Spannmuttern DIN 6388  
(ISO 10897) System OZ,  
für Dichtscheiben**

Clamping nuts DIN 6388 D (ISO 10897)  
OZ-system, for sealing discs  
Ecrus de serrage DIN 6388 D  
(ISO 10897) système OZ, pour joints

Bestell-Nr. Order no. / Référence	Abmessung Size / Dimension	Euro
113.01.16	2 – 16 (OZ 16)	65,00
113.01.25	2 – 25 (OZ 25)	72,00
113.01.32	3 – 32 (OZ 32)	84,00



**Spannmuttern DIN 6499  
(ISO 15488) System ER,  
für Dichtscheiben**

Clamping nuts DIN 6499 (ISO 15488)  
ER-system, for sealing discs  
Ecrus de serrage DIN 6499  
(ISO 15488) système ER, pour joints

Bestell-Nr. Order no. / Référence	Abmessung Size / Dimension	Euro
113.02.10*	1 – 10 (ER 16) SW 25	41,00
113.02.16	2 – 16 (ER 25)	48,00
113.02.20	2 – 20 (ER 32)	51,00
113.02.26	3 – 26 (ER 40)	59,00

- \* Sechskantmutter
- \* Hexagonal clamping nut
- \* Écrus hexagonal



**Spannmuttern DIN 6499  
(ISO 15488) System ER,  
mit Spritzdüsen,  
für Dichtscheiben**

Clamping nuts DIN 6499 (ISO 15488)  
ER-system, with spray nozzles,  
for sealing discs  
Ecrus de serrage DIN 6499  
(ISO 15488) système ER,  
avec gicleurs, pour joints

Bestell-Nr. Order no. / Référence	Abmessung Size / Dimension	Euro
114.02.10*	1 – 10 (ER 16)	70,00
114.02.16	2 – 16 (ER 25)	75,00
114.02.20	2 – 20 (ER 32)	79,00
114.02.26	3 – 26 (ER 40)	87,00

- \* Sechskantmutter
- \* Hexagonal clamping nut
- \* Écrus hexagonal



**Dichtscheiben für Spannmuttern  
System OZ**

Sealing discs for clamping nuts  
OZ-system  
Joints pour écrous de serrage  
système OZ

Bestell-Nr. Order no. / Référence	Abmessung Size / Dimension	Euro
01.16.--	2,0 – 6,0 (OZ 16)	18,00
	6,5 – 16,0 (OZ 16)	17,00
01.25.--	2,0 – 6,0 (OZ 25)	18,00
	6,5 – 25,0 (OZ 25)	15,00
01.32.--	3,0 – 6,0 (OZ 32)	20,00
	6,5 – 32,0 (OZ 32)	16,00

0,5 mm steigend  
0.5 mm steps  
0,5 mm croissant



**Dichtscheiben für Spannmuttern  
System ER**

Sealing discs for clamping nuts  
ER-system  
Joints pour écrous de serrage  
système ER

Bestell-Nr. Order no. / Référence	Abmessung Size / Dimension	Euro
02.10.--	1,0 – 6,0 (ER 16)	13,00
	6,5 – 10,0 (ER 16)	17,00
02.16.--	1,0 – 6,0 (ER 25)	14,00
	6,5 – 16,0 (ER 25)	18,00
02.20.--	1,0 – 6,0 (ER 32)	18,00
	6,5 – 20,0 (ER 32)	18,00
02.26--	2,0 – 6,0 (ER 40)	26,00
	6,5 – 26,0 (ER 40)	19,00

0,5 mm steigend  
0.5 mm steps  
0,5 mm croissant

Внимание! Данный прайс-лист для европейского рынка.

Цены в РФ значительно отличаются от цен, указанных в данном документе!

Для получения актуальной стоимости, обращайтесь по контактам, указанным ниже.

kemmler@kemmler.su  
www.kemmler.su

**Zubehör**  
Accessories  
Accessoires



**Spannmuttern DIN 6388 D (ISO 10897) System OZ, kugelgelagerte Ausführung**  
Clamping nuts DIN 6388 D (ISO 10897) OZ-system, ball-bearing version  
Ecrous de serrage DIN 6388 D (ISO 10897) système OZ, version roulement à billes

Bestell-Nr. Order no. / Référence	Abmessung Size / Dimension	Euro
112.01.16	2 – 16 (OZ 16)	27,00
112.01.25	2 – 25 (OZ 25)	34,00
112.01.32	3 – 32 (OZ 32)	44,00



**Spannmuttern DIN 6499 (ISO 15488) System ER, Minimutter mit Exzenterring, gewuchtet**  
Clamping nuts DIN 6499 (ISO 15488) ER-system, mini type with eccentric ring, balanced  
Ecrous de serrage DIN 6499 (ISO 15488) système ER, version mini avec bague excentrique, équilibrés

Bestell-Nr. Order no. / Référence	Abmessung Size / Dimension	Euro
110.02.07.3	1 – 7 (ER 11)	20,00
110.02.10.3	1 – 10 (ER 16)	20,00

Minimutter | mini nut | écrous-mini



**Spannmuttern DIN 6499 (ISO 15488) System ER, Standardausführung mit Exzenterring, gewuchtet**  
Clamping nuts DIN 6499 (ISO 15488) ER-system, standard type with eccentric ring, balanced  
Ecrous de serrage DIN 6499 (ISO 15488) système ER, version standard avec bague excentrique, équilibrés

Bestell-Nr. Order no. / Référence	Abmessung Size / Dimension	Euro
110.02.10	1 – 10 (ER 16)	20,00
110.02.16	2 – 16 (ER 25)	20,00
110.02.20	2 – 20 (ER 32)	21,00
110.02.26	3 – 26 (ER 40)	27,00



**Spannmuttern DIN 6499 (ISO 15488) System ER, gleitgelagerte Ausführung**  
Clamping nuts DIN 6499 (ISO 15488) ER-system, sleeve-bearing version  
Ecrous de serrage à palier lisse pour pinces DIN 6499 (ISO 15488) système ER

Bestell-Nr. Order no. / Référence	Abmessung Size / Dimension	Euro
112.02.10*	1 – 10 (ER 16) SW 25	35,00
112.02.16	2 – 16 (ER 25)	37,00
112.02.20	2 – 20 (ER 32)	50,00
112.02.26	3 – 26 (ER 40)	59,00

\* Sechskantmutter  
\* Hexagonal clamping nut  
\* Écrous hexagonal



**Spannmuttern DIN 6499 (ISO 15488) System ER, Sechskantmutter mit Exzenterring, gewuchtet**  
Clamping nuts DIN 6499 (ISO 15488) ER-system, hexagonal clamping nut with eccentric ring, balanced  
Ecrous de serrage DIN 6499 (ISO 15488) système ER, Écrous hexagonal avec bague excentrique, équilibrés

Bestell-Nr. Order no. / Référence	Abmessung Size / Dimension	Euro
110.02.07.6	1 – 7 (ER 11) SW 17	27,00
110.02.10.6	1 – 10 (ER 16) SW 25	20,00
110.02.13.6	2 – 13 (ER 20) SW 30	27,00



**Verstellerschrauben für Spannfutter**  
Adjusting Screws for collet chucks  
Vis de réglage pour mandrin de serrage

Bestell-Nr. Order no. / Référence	Abmessung Size / Dimension	Euro
101.02.05	ER16 M10 x 1,5 - 20mm	3,00
101.02.10	ER20 M12 x 1,75 - 20mm	4,00
101.02.15	ER25 / ER32 / ER40 M16 x 2,0 - 20mm	5,00



Внимание! Данный прайс-лист для европейского рынка.  
Цены в РФ значительно отличаются от цен, указанных в данном документе!  
Для получения актуальной стоимости, обращайтесь по контактам, указанным ниже.



**Zubehör**  
Accessories  
Accessoires



**Hakenschlüssel DIN 1810 A  
für Spannmutter System OZ**  
Wrenches DIN 1810 A  
for clamping nuts OZ-system  
Clés à ergot DIN 1810 A  
pour écrous de serrage système OZ

Bestell-Nr. Order no. / Référence	Abmessung Size / Dimension	Euro
01.16	2 – 16 (OZ 16)	8,00
01.25	2 – 25 (OZ 25)	11,00
01.32	3 – 32 (OZ 32)	12,00



**Spannschlüssel  
für Spannmutter System ER**  
Wrenches for clamping nuts  
ER-system  
Clés de serrage pour écrous  
de serrage système ER

Bestell-Nr. Order no. / Référence	Abmessung Size / Dimension	Euro
02.10.1	1 – 10 (ER 16)	14,00
02.13	2 – 13 (ER 20)	17,00
02.16	2 – 16 (ER 25)	14,00
02.20	2 – 20 (ER 32)	18,00
02.26	2 – 26 (ER 40)	26,00



**Spannschlüssel  
für Spannmutter System ER**  
Wrenches for clamping nuts  
ER-system  
Clés de serrage pour écrous  
de serrage système ER

Bestell-Nr. Order no. / Référence	Abmessung Size / Dimension	Euro
02.07*	1 – 7 (ER 11) SW 17	17,00
02.10*	1 – 10 (ER 16) SW 25	13,00
02.13.1*	2 – 13 (ER 20) SW 30	23,00

\* Für Sechskantmutter  
\* For hexagonal clamping nuts  
\* Pour écrous hexagonals



**Mini Spannschlüssel  
für Spannmutter System ER**  
Mini wrenches for clamping nuts  
ER-system  
Mini clés de serrage pour écrous  
de serrage système ER

Bestell-Nr. Order no. / Référence	Abmessung Size / Dimension	Euro
02.07.3	1 – 7 (ER 11) Mini	15,00
02.10.3	1 – 10 (ER 16) Mini	16,00
02.13.3	2 – 13 (ER 20) Mini	19,00



**Sechskantschlüssel**  
Hexagonal wrench  
Clés hexagonale

Bestell-Nr. Order no. / Référence	Abmessung Size / Dimension	Euro
T-4-100	4-100	6,00
T-5-100	5-100	6,00
T-6-100	6-100	6,00

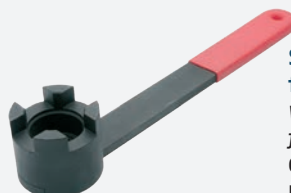

**Spannschlüssel DIN 6368  
für Aufsteckdorne**  
Wrenches DIN 6368  
for shell arbors  
Clés de serrage DIN 6368  
pour broches creuses

Bestell-Nr. Order no. / Référence	Abmessung Size / Dimension	Euro
10.16	16 / M8	13,00
10.22	22 / M10	16,00
10.27	27 / M12	19,00
10.32	32 / M16	24,00
10.40	40 / M20	33,00

Внимание! Данный прайс-лист для европейского рынка.

Цены в РФ значительно отличаются от цен, указанных в данном документе!

Для получения актуальной стоимости, обращайтесь по контактам, указанным ниже.

kemmler@kemmler.su  
www.kemmler.su

**Zubehör**  
Accessories  
Accessoires



**Drehmomentschlüssel**  
Universal Torque Wrenches  
Clés dynamométriques

Bestell-Nr. Order no. / Référence	Abmessung Size / Dimension	Euro
800.030	60 – 300 Nm	167,00



**Schlüsseleinsätze für Anzugsbolzen**  
Wrench inserts for Pull studs  
Inserts pour tirettes

Bestell-Nr. Order no. / Référence	Abmessung Size / Dimension	Euro
800.20.13	BT 30 – SW 13	34,00
800.20.14	SK 30 – SW 14	34,00
800.20.19	SK / BT 40 – SW 19	34,00
800.20.30	SK / BT 50 – SW 30	34,00



**Schlüsseleinsätze für Spannmuttern System OZ**  
Wrench inserts for clamping nuts OZ-system  
Inserts pour clés dynamométriques pour écrous de serrage système OZ

Bestell-Nr. Order no. / Référence	Abmessung Size / Dimension	Euro
800.01.16	2 – 16 (OZ 16)	34,00
800.01.25	2 – 25 (OZ 25)	34,00
800.01.32	3 – 32 (OZ 32)	34,00



**Schlüsseleinsätze für Spannmuttern System ER, mit Sechskant**  
Wrench inserts for clamping nuts ER-system, with hexagon  
Inserts pour clés dynamométriques pour écrous de serrage système ER, avec hexagone

Bestell-Nr. Order no. / Référence	Abmessung Size / Dimension	Euro
800.02.10	1 – 10 (ER 16) SW 25	34,00
800.02.10.2	1 – 10 (ER 16) SW 27	34,00



**Schlüsseleinsätze für Spannmuttern System ER**  
Wrench inserts for clamping nuts ER-system  
Inserts pour clés dynamométriques pour écrous de serrage système ER

Bestell-Nr. Order no. / Référence	Abmessung Size / Dimension	Euro
800.02.10.1	1 – 10 (ER 16)	34,00
800.02.16	2 – 16 (ER 25)	34,00
800.02.20	2 – 20 (ER 32)	34,00
800.02.26	2 – 26 (ER 40)	34,00

**Внимание! Данный прайс-лист для европейского рынка.**  
Цены в РФ значительно отличаются от цен, указанных в данном документе!  
Для получения актуальной стоимости, обращайтесь по контактам, указанным ниже.







## Анзугболзены DIN 69872 A+B

Pull studs DIN 69872 A+B

Tirettes DIN 69872 A+B

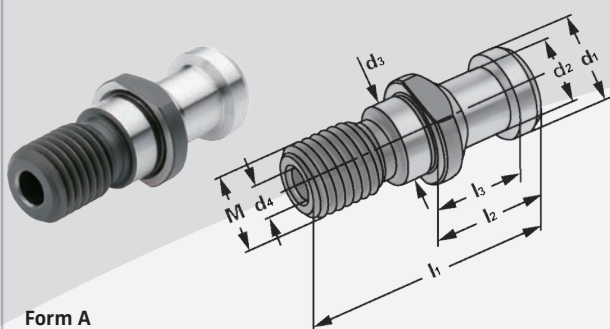

Form A  
Form A  
Forme A

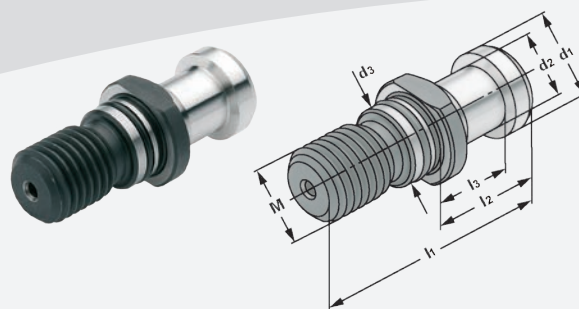

Form B  
Form B  
Forme B

Bestell-Nr. Order no. / Référence	M	l <sub>1</sub>	l <sub>2</sub>	l <sub>3</sub>	d <sub>1</sub>	d <sub>2</sub>	d <sub>3</sub>	d <sub>4</sub>	Euro
302.20.12	M12	44	24	19	13	9	13	3,0	7,00
402.20.16	M16	54	26	20	19	14	17	7,0	7,00
502.20.24	M24	74	34	25	28	21	25	11,5	8,00

Form A (mit Durchgangsbohrung, ohne O-Ring) DIN 69872 A  
Form A (with drill through, without O-ring) DIN 69872 A  
Forme A (percée, sans joint torique) DIN 69872 A

402.20.16.0	M16	54	26	20	19	14	17	7,0	8,00
502.20.24.0	M24	74	34	25	28	21	25	11,5	10,00

Form A (mit Durchgangsbohrung, inkl. O-Ring) DIN 69872 A  
Form A (with drill through, incl. O-ring) DIN 69872 A  
Forme A (percée, avec joint torique) DIN 69872 A

403.20.16	M16	54	26	20	19	14	17	–	8,00
503.20.24	M24	74	34	25	28	21	25	–	9,00

Form B (ohne Durchgangsbohrung, inkl. O-Ring) DIN 69872 B  
Form B (sealed, incl. O-ring) DIN 69872 B  
Forme B (étanche, avec joint torique) DIN 69872 B



## Анзугболзены аанлиа DIN 69872 А, ум 3 мм верлэнгерт

Pull studs similar to DIN 69872 A, lengthened by 3 mm

Tirettes ressemblant à DIN 69872 A, allongé par 3 mm

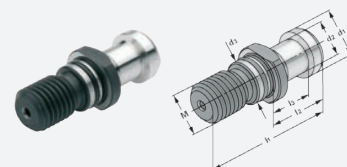

Bestell-Nr. Order no. / Référence	M	l <sub>1</sub>	l <sub>2</sub>	l <sub>3</sub>	d <sub>1</sub>	d <sub>2</sub>	d <sub>3</sub>	d <sub>4</sub>	Euro
402.20.16.21	M16	54	29	23	19	14	17	7,0	10,00

Form A (mit Durchgangsbohrung, inkl. O-Ring)  
Form A (with drill through, incl. O-ring)  
Forme A (percée, avec joint torique)

Sonderbolzen auf Anfrage kurzfristig lieferbar.  
Special pull studs available within a short period upon request.  
Tirettes spéciales livrables dans un délai court sur demande.

Внимание! Данный прайс-лист для европейского рынка.

Цены в РФ значительно отличаются от цен, указанных в данном документе!

Для получения актуальной стоимости, обращайтесь по контактам, указанным ниже.

kemmler@kemmler.su  
www.kemmler.su



## Анзугболзены ISO 7388

Pull studs ISO 7388

Tirettes ISO 7388

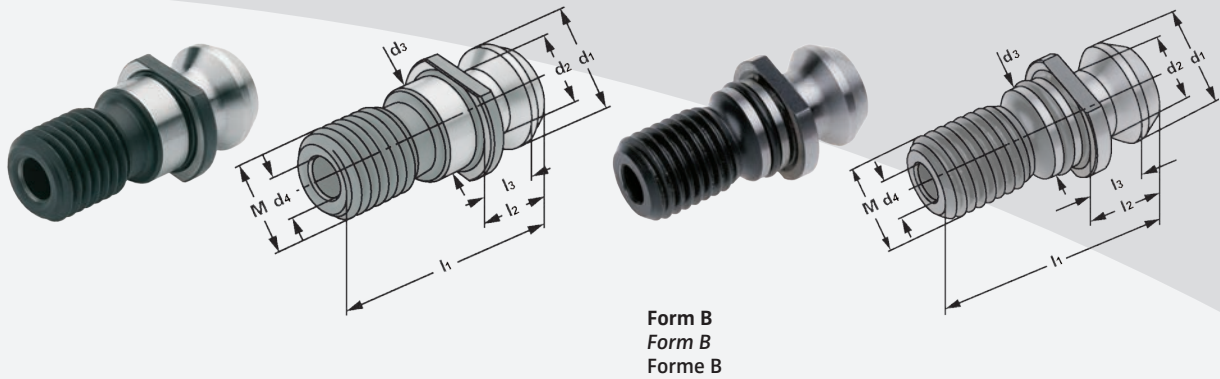

Bestell-Nr. Order no. / Référence	M	l <sub>1</sub>	l <sub>2</sub>	l <sub>3</sub>	d <sub>1</sub>	d <sub>2</sub>	d <sub>3</sub>	d <sub>4</sub>	Euro
404.20.16	M16	44,5	16,40	11,15	18,95	12,95	17	7,0	7,00
504.20.24	M24	65,5	25,55	17,95	29,10	19,60	25	11,5	8,00

Form II B (mit Durchgangsbohrung, ohne O-Ring)

Form II B (with drill through, without O-ring)

Forme II B (percée, sans joint torique)

404.20.16.0	M16	44,5	16,40	11,15	18,95	12,95	17	7,0	8,00
504.20.24.0	M24	65,5	25,55	17,95	29,10	19,60	25	11,5	9,00

Form II B (mit Durchgangsbohrung, inkl. O-Ring)

Form II B (with drill through, incl. O-ring)

Forme II B (percée, avec joint torique)

404.20.16.30	M16	44,5	16,40	11,15	18,95	12,95	17	–	10,00
504.20.24.30	M24	65,5	25,55	17,95	29,10	19,60	25	–	11,00

Form 7388 (ohne Durchgangsbohrung, inkl. O-Ring)

Form 7388 (sealed, incl. O-ring)

Forme 7388 (étanche, avec joint torique)

## Анзугболзены аанчлво ISO 7388, ум 3 мм верлэнгерт

Pull studs similar to ISO 7388, lengthened by 3 mm

Tirettes ressemblant à ISO 7388, allongé par 3 mm

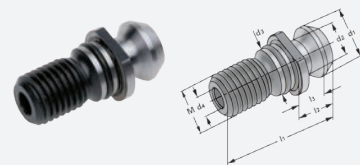

Bestell-Nr. Order no. / Référence	M	l <sub>1</sub>	l <sub>2</sub>	l <sub>3</sub>	d <sub>1</sub>	d <sub>2</sub>	d <sub>3</sub>	d <sub>4</sub>	Euro
404.20.16.20	M16	47,50	19,25	14,15	18,95	12,95	17,00	7,3	10,00

Mit Durchgangsbohrung, inkl. O-Ring

With drill through, incl. O-ring

Percée, avec joint torique

Внимание! Данный прайс-лист для европейского рынка.  
Цены в РФ значительно отличаются от цен, указанных в данном документе!  
Для получения актуальной стоимости, обращайтесь по контактам, указанным ниже.



## Анзугболzen CAT метрич

Pull studs CAT metric

Tirettes CAT métrique

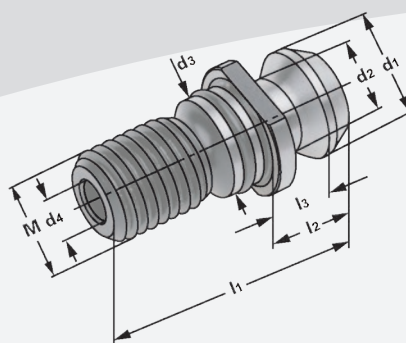

Bestell-Nr.									Euro
Order no. / Référence	M	l <sub>1</sub>	l <sub>2</sub>	l <sub>3</sub>	d <sub>1</sub>	d <sub>2</sub>	d <sub>3</sub>	d <sub>4</sub>	
404.20.16.21	M16	41,26	16,26	11,18	18,80	12,45	17,00	7,0	7,00

Mit Durchgangsbohrung, inkl. O-Ring  
With drill through, incl. O-ring  
Percée, avec joint torique

504.20.24.21	M24	65,40	25,40	17,80	28,95	20,80	25,00	11,5	13,00
--------------	-----	-------	-------	-------	-------	-------	-------	------	-------

SK 50 mit Freidrehung im Kopf für O-Ring  
SK 50 with open head rotation for O-rings  
SK 50 avec rotation libre du tête pour joints ronds

## Анзугболzen CAT метрич für Hochdruckkühlung

Pull studs CAT metric for high-pressure cooling

Tirettes CAT métrique pour refroidissement sous haute pression

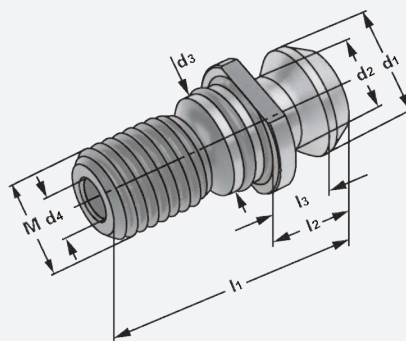

Bestell-Nr.									Euro
Order no. / Référence	M	l <sub>1</sub>	l <sub>2</sub>	l <sub>3</sub>	d <sub>1</sub>	d <sub>2</sub>	d <sub>3</sub>	d <sub>4</sub>	
404.20.16.22	M16	41,26	16,26	11,18	18,80	12,45	17,00	7,0	11,00
504.20.24.22	M24	65,40	25,40	17,80	28,95	20,80	25,00	11,5	18,00

Mit Durchgangsbohrung, inkl. O-Ringen in der Bohrung und am Bund  
With drill through, incl. O-rings in the bore and the collar  
Percée, avec joints toriques dans le perçage et à la collerette

Внимание! Данный прайс-лист для европейского рынка.

Цены в РФ значительно отличаются от цен, указанных в данном документе!

Для получения актуальной стоимости, обращайтесь по контактам, указанным ниже.

## Анзугболзены JIS B 6339 (MAS 403 BT)

Pull studs JIS B 6339 (MAS 403 BT)

Tirettes JIS B 6339 (MAS 403 BT)

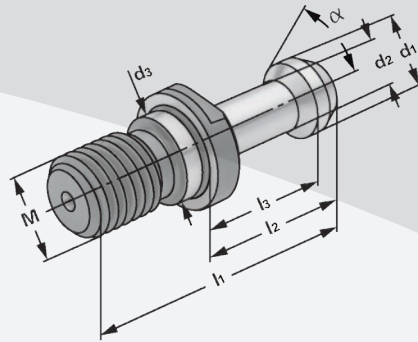

Bestell-Nr. Order no. / Référence	M	l <sub>1</sub>	l <sub>2</sub>	l <sub>3</sub>	d <sub>1</sub>	d <sub>2</sub>	d <sub>3</sub>	Euro
305.20.45	M12 – 45°	43	23	18	11	7	12,5	7,00
305.20.60	M12 – 60°	43	23	18	11	7	12,5	7,00
405.20.45	M16 – 45°	60	35	28	15	10	17,0	7,00
405.20.60	M16 – 60°	60	35	28	15	10	17,0	7,00
405.20.90	M16 – 90°	60	35	28	15	10	17,0	7,00
505.20.45	M24 – 45°	85	45	35	23	17	25,0	8,00
505.20.60	M24 – 60°	85	45	35	23	17	25,0	8,00
505.20.90	M24 – 90°	85	45	35	23	17	25,0	8,00

Ohne Durchgangsbohrung, ohne O-Ring  
Sealed, without O-ring  
Étanche, sans joint torique

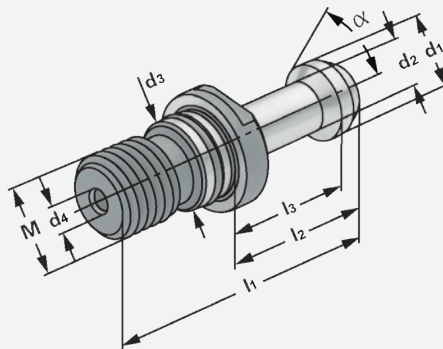

Bestell-Nr. Order no. / Référence	M	l <sub>1</sub>	l <sub>2</sub>	l <sub>3</sub>	d <sub>1</sub>	d <sub>2</sub>	d <sub>3</sub>	d <sub>4</sub>	Euro
306.20.45	M12 – 45°	43	23	18	11	7	12,5	2,5	7,00
306.20.60	M12 – 60°	43	23	18	11	7	12,5	2,5	7,00
406.20.45	M16 – 45°	60	35	28	15	10	17,0	4,0	8,00
406.20.60	M16 – 60°	60	35	28	15	10	17,0	4,0	8,00
406.20.90	M16 – 90°	60	35	28	15	10	17,0	4,0	8,00
506.20.45	M24 – 45°	85	45	35	23	17	25,0	6,0	9,00
506.20.60	M24 – 60°	85	45	35	23	17	25,0	6,0	9,00
506.20.90	M24 – 90°	85	45	35	23	17	25,0	6,0	9,00

Mit Durchgangsbohrung, inkl. O-Ring  
With drill through, incl. O-ring  
Percée, avec joint torique

Внимание! Данный прайс-лист для европейского рынка.  
Цены в РФ значительно отличаются от цен, указанных в данном документе!  
Для получения актуальной стоимости, обращайтесь по контактам, указанным ниже.





## Анзугболзены Хаас аһныч JIS B 6399 (MAS 403 BT), ум 3 мм веркүрзт

Pull studs Haas similar to JIS B 6399 (MAS 403 BT), shortened by 3 mm

Tirettes Haas ressemblant à JIS B 6399 (MAS 403 BT), raccourci par 3 mm

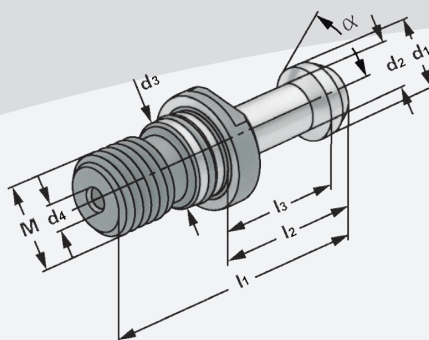

Bestell-Nr.									Euro
Order no. / Référence	M	l <sub>1</sub>	l <sub>2</sub>	l <sub>3</sub>	d <sub>1</sub>	d <sub>2</sub>	d <sub>3</sub>	d <sub>4</sub>	
405.20.45.21	M16 – 45°	57	32	25	15	10	17	4,0	9,00
405.20.60.21	M16 – 60°	57	32	25	15	10	17	4,0	9,00
405.20.90.21	M16 – 90°	57	32	25	15	10	17	4,0	9,00

**Mit Durchgangsbohrung, inkl. O-Ring**

With drill through, incl. O-ring

Percée, avec joint torique

Bestell-Nr.									Euro
Order no. / Référence	M	l <sub>1</sub>	l <sub>2</sub>	l <sub>3</sub>	d <sub>1</sub>	d <sub>2</sub>	d <sub>3</sub>	d <sub>4</sub>	
406.20.45.21	M16 – 45°	57	32	25	15	10	17		9,00
406.20.60.21	M16 – 60°	57	32	25	15	10	17		9,00
406.20.90.21	M16 – 90°	57	32	25	15	10	17		9,00

**Ohne Durchgangsbohrung, inkl. O-Ring**

Sealed, incl. O-ring

Étanche, avec joint torique



Sonderbolzen auf Anfrage kurzfristig lieferbar.

Special pull studs available within a short period upon request.

Tirettes spéciales livrables dans un délai court sur demande.

**Внимание! Данный прайс-лист для европейского рынка.**

Цены в РФ значительно отличаются от цен, указанных в данном документе!

Для получения актуальной стоимости, обращайтесь по контактам, указанным ниже.





## Анзугболзы DIN 2080 мит Отт-Рингнут

Pull studs DIN 2080 with Ott-groove

Tirettes DIN 2080 avec gorge Ott

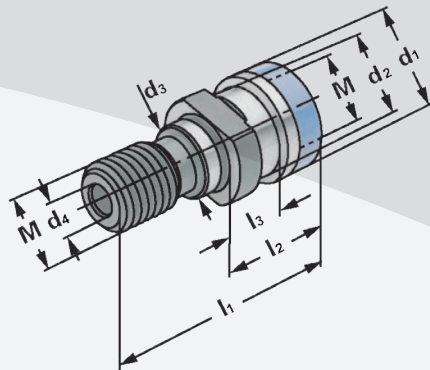

Bestell-Nr. Order no. / Référence	M	l <sub>1</sub>	l <sub>2</sub>	l <sub>3</sub>	d <sub>1</sub>	d <sub>2</sub>	d <sub>3</sub>	d <sub>4</sub>	Euro
401.20.16	M16	53,0	25,1	13,6	25,00	21,1	17	7,0	9,00
501.20.24	M24	65,1	25,1	13,3	39,60	32,0	25	7,0	10,00

**Mit Innengewinde und Durchgangsbohrung**  
With internal thread and drill through  
Avec filetage intérieur et perçage

**Hinweis:** Mit Kantenschutzring  
**Note:** With protection ring  
**Observation:** Avec bague de protection

## Анзугболзы S 20 × 2

Pull studs S 20 × 2

Tirettes S 20 × 2

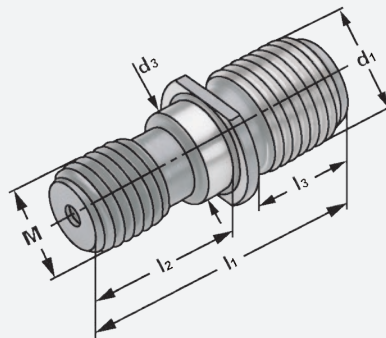

Bestell-Nr. Order no. / Référence	M	l <sub>1</sub>	l <sub>2</sub>	l <sub>3</sub>	d <sub>1</sub>	d <sub>3</sub>	Euro
401.20.16.S	M16	56,0	28,0	19,0	S 20 × 2	17,0	16,00

Внимание! Данный прайс-лист для европейского рынка.

Цены в РФ значительно отличаются от цен, указанных в данном документе!

Для получения актуальной стоимости, обращайтесь по контактам, указанным ниже.

kemmler@kemmler.su  
www.kemmler.su

**KEMMLER**





## Сnellwechsel-Einsätze für Gewindeschneidfutter

Quick change adaptors for tapping chucks

Adaptateurs à changement rapide pour mandrins de taraudage



### Еinsätze mit Rutschkupplung

Adaptors with clutch

Adaptateurs avec limiteur de couple

Bestell-Nr. Order no. / Référence	Abmessung Size / Dimension	Euro
16.11.335	Gr. 1 M3 - 3,5 × 2,7	35,00
16.11.354	Gr. 1 M3,5 - 4 × 3	35,00
16.11.445	Gr. 1 M4 - 4,5 × 3,4	35,00
16.11.5649	Gr. 1 M5 - 6 × 4,9	35,00
16.11.6649	Gr. 1 M6 - 6 × 4,9	35,00
16.11.88	Gr. 1 M8 - 8 × 6,2	35,00
16.11.107	Gr. 1 M10 - 7 × 5,5	35,00
16.11.1010	Gr. 1 M10 - 10 × 8	35,00
16.11.129	Gr. 1 M12 - 9 × 7	35,00
16.11.14119	Gr. 1 M14 - 11 × 9	35,00
16.12.5649	Gr. 2 M5 - 6 × 4,9	50,00
16.12.6649	Gr. 2 M6 - 6 × 4,9	50,00
16.12.88	Gr. 2 M8 - 8 × 6,2	50,00
16.12.107	Gr. 2 M10 - 7 × 5,5	50,00
16.12.1010	Gr. 2 M10 - 10 × 8	50,00
16.12.129	Gr. 2 M12 - 9 × 7	50,00
16.12.1411	Gr. 2 M14 - 11 × 9	50,00
16.12.1612	Gr. 2 M16 - 12 × 9	50,00
16.12.181411	Gr. 2 M18 - 14 × 11	50,00
16.12.2016	Gr. 2 M20 - 16 × 12	50,00
16.12.2218145	Gr. 2 M22 - 18 × 14,5	50,00
16.13.14119	Gr. 3 M14 - 11 × 9	104,00
16.13.16129	Gr. 3 M16 - 12 × 9	104,00
16.13.181411	Gr. 3 M18 - 14 × 11	104,00
16.13.201612	Gr. 3 M20 - 16 × 12	104,00
16.13.2218145	Gr. 3 M22 - 18 × 14,5	104,00
16.13.2418145	Gr. 3 M24 - 18 × 14,5	104,00
16.13.272016	Gr. 3 M27 - 20 × 16	104,00
16.13.302218	Gr. 3 M30 - 22 × 18	104,00
16.13.332520	Gr. 3 M33 - 25 × 20	104,00
16.13.362822	Gr. 3 M36 - 28 × 22	104,00



### Еinsätze ohne Rutschkupplung

Adaptors without clutch

Adaptateurs sans limiteur de couple

Bestell-Nr. Order no. / Référence	Abmessung Size / Dimension	Euro
16.01.3527	Gr. 1 3,5 × 2,7	16,00
16.01.43	Gr. 1 4 × 3	16,00
16.01.4534	Gr. 1 4,5 × 3,4	16,00
16.01.649	Gr. 1 6 × 4,9	16,00
16.01.755	Gr. 1 7 × 5,5	16,00
16.01.862	Gr. 1 8 × 6,2	16,00
16.01.97	Gr. 1 9 × 7	16,00
16.01.108	Gr. 1 10 × 8	16,00
16.01.119	Gr. 1 11 × 9	16,00
16.02.649	Gr. 2 6 × 4,9	24,00
16.02.755	Gr. 2 7 × 5,5	24,00
16.02.862	Gr. 2 8 × 6,2	24,00
16.02.97	Gr. 2 9 × 7	24,00
16.02.108	Gr. 2 10 × 8	24,00
16.02.119	Gr. 2 11 × 9	24,00
16.02.129	Gr. 2 12 × 9	24,00
16.02.1411	Gr. 2 14 × 11	24,00
16.02.1612	Gr. 2 16 × 12	24,00
16.02.18145	Gr. 2 18 × 14,5	24,00
16.03.119	Gr. 3 11 × 9	50,00
16.03.129	Gr. 3 12 × 9	50,00
16.03.1411	Gr. 3 14 × 11	50,00
16.03.1612	Gr. 3 16 × 12	50,00
16.03.18145	Gr. 3 18 × 14,5	50,00
16.03.2016	Gr. 3 20 × 16	50,00
16.03.2218	Gr. 3 22 × 18	50,00
16.03.2520	Gr. 3 25 × 20	50,00
16.03.2822	Gr. 3 28 × 22	50,00



**Zubehör**  
Accessories  
Accessoires



**Reduzieradapter für Schnellwechsel-Einsätze**  
*Reducing adaptors for quick change adaptors*  
Réductions pour adaptateurs à changement rapide

Bestell-Nr. Order no. / Référence	Abmessung Size / Dimension	Euro
16.00.0201	2 - 1	69,00
16.00.0302	3 - 2	116,00



**Gewindeschneid-Schnellwechselfutter mit Längenausgleich auf Druck und Zug für Zylinderschäfte DIN 1835 B+E**  
*Quick-change tapping chucks with length compensation on compression and expansion for tool shanks DIN 1835 B+E*  
Mandrins de taraudage à changement rapide avec compensation longitudinale à la compression et traction pour queues cylindriques DIN 1835 B+E

Bestell-Nr. Order no. / Référence	Abmessung Size / Dimension	Euro
120.16.2012	20 - M3 / M14 Gr. 1	135,00
120.16.2020	20 - M5 / M22 Gr. 2	179,00



**Gewindeschneid-Schnellwechselfutter mit Längenausgleich auf Druck und Zug DIN 228-1 B**  
*Quick-change tapping chucks with length compensation on compression and expansion DIN 228-1 B*  
Mandrins de taraudage à changement rapide avec compensation longitudinale à la compression et traction DIN 228-1 B

Bestell-Nr. Order no. / Référence	Abmessung Size / Dimension	Euro
107.16.212	MK 2 - M3 / M14 Gr. 1	135,00
107.16.312	MK 3 - M3 / M14 Gr. 1	179,00
107.16.320	MK 3 - M5 / M22 Gr. 2	179,00
107.16.412	MK 4 - M3 / M14 Gr. 1	190,00
107.16.420	MK 4 - M5 / M22 Gr. 2	230,00
107.16.436	MK 4 - M14/M36Gr. 3	350,00



**Gewindeschneidfutter für Synchronisation mit Zylinderschaft DIN 1835 B+E für Spannzangen DIN 6499 (ISO 15488) System ER**  
*Tapping chucks for synchronisation with tool shanks DIN 1835 B+E for collets DIN 6499 (ISO 15488) ER-system*  
Mandrins de taraudage pour synchronisation avec queues cylindriques DIN 1835 B+E pour pinces DIN 6499 (ISO 15488) système ER

Bestell-Nr. Order no. / Référence	Abmessung Size / Dimension	Euro
120.16.2016	20 - M3 / M10 ER 16	401,00
120.16.2025	20 - M3 / M20 ER 25	410,00
120.16.2516	25 - M3 / M10 ER 16	345,00
120.16.2525	25 - M3 / M20 ER 25	419,00
120.16.2532	25 - M4 / M27 ER 32	352,00
120.16.2540	25 - M4 / M33 ER 40	493,00
120.16.4032	32 - M4 / M27 ER 32	494,00
120.16.4040	32 - M4 / M33 ER 40	494,00



**Внимание! Данный прайс-лист для европейского рынка.**  
Цены в РФ значительно отличаются от цен, указанных в данном документе!  
Для получения актуальной стоимости, обращайтесь по контактам, указанным ниже.



**Гewindeschneid-Schnellwechselfutter  
DIN 69871 A mit Längenausgleich  
auf Druck und Zug im Holzkasten  
inkl. Einsätze mit Rutschkupplung**

*Quick-change tapping chucks DIN 69871 A  
with length compensation in a wooden box  
incl. tapping collets with clutch*

*Mandrin de taraudage DIN 69871 A  
avec compensation longitudinale dans coffret  
en bois incl. douilles avec limiteur de couple*

Bestell Nr. <i>Order no. / Réf.</i>	Abmessung <i>Size / Dimension</i>	Größe <i>Size/ Taille</i>	Stück <i>Pcs.</i>	Euro
402.16.12.SR	SK 40 - M3 / M14	Gr. 1	8	496,00
402.16.20.SR	SK 40 - M5 / M22	Gr. 2	10	733,00
502.16.12.SR	SK 50 - M3 / M14	Gr. 1	8	540,00
502.16.20.SR	SK 50 - M5 / M22	Gr. 2	10	768,00



**Гewindeschneid-Schnellwechselfutter  
DIN 69871 A mit Längenausgleich  
auf Druck und Zug im Holzkasten  
inkl. Einsätze ohne Rutschkupplung**

*Quick-change tapping chucks DIN 69871 A  
with length compensation in a wooden box  
incl. tapping collets without clutch*

*Mandrin de taraudage DIN 69871 A avec  
compensation longitudinale dans coffret en  
bois incl. douilles sans limiteur de couple*

Bestell Nr. <i>Order no. / Réf.</i>	Abmessung <i>Size / Dimension</i>	Größe <i>Size/ Taille</i>	Stück <i>Pcs.</i>	Euro
402.16.12.S	SK 40 - M3 / M14	Gr. 1	7	329,00
402.16.20.S	SK 40 - M5 / M22	Gr. 2	9	438,00
502.16.12.S	SK 50 - M3 / M14	Gr. 1	7	373,00
502.16.20.S	SK 50 - M5 / M22	Gr. 2	9	482,00



**Еinsätze mit Rutschkupplung**

*Tapping collets with clutch*

*Douilles avec limiteur de couple*



**Еinsätze ohne Rutschkupplung**

*Tapping collets without clutch*

*Douilles sans limiteur de couple*

Abmessung <i>Size / Dimension</i>	Abmessung <i>Size / Dimension</i>
Gr. 1 M3 - 3,5 × 2,7 DIN 371	Gr. 2 M5 - 6 × 4,9 DIN 371
Gr. 1 M4 - 4,5 × 3,4 DIN 371	Gr. 2 M6 - 6 × 4,9 DIN 371
Gr. 1 M5 - 6 × 4,9 DIN 371	Gr. 2 M8 - 8 × 6,2 DIN 371
Gr. 1 M6 - 6 × 4,9 DIN 371	Gr. 2 M10 - 10 × 8 DIN 371
Gr. 1 M8 - 8 × 6,2 DIN 371	Gr. 2 M12 - 9 × 7 DIN 376
Gr. 1 M10 - 10 × 8 DIN 371	Gr. 2 M14 - 11 × 9 DIN 376
Gr. 1 M12 - 9 × 7 DIN 376	Gr. 2 M16 - 12 × 9 DIN 376
Gr. 1 M14 - 11 × 9 DIN 376	Gr. 2 M18 - 14 × 11 DIN 376
	Gr. 2 M20 - 16 × 12 DIN 376
	Gr. 2 M22 - 18 × 14,5 DIN 376

Abmessung <i>Size / Dimension</i>	Abmessung <i>Size / Dimension</i>
Gr. 1 3,5 × 2,7	Gr. 2 6 × 4,9
Gr. 1 4,5 × 3,4	Gr. 2 8 × 6,2
Gr. 1 6 × 4,9	Gr. 2 9 × 7
Gr. 1 8 × 6,2	Gr. 2 10 × 8
Gr. 1 9 × 7	Gr. 2 11 × 9
Gr. 1 10 × 8	Gr. 2 12 × 9
Gr. 1 11 × 9	Gr. 2 14 × 11
	Gr. 2 16 × 12
	Gr. 2 18 × 14,5

**Внимание! Данный прайс-лист для европейского рынка.**

**Цены в РФ значительно отличаются от цен, указанных в данном документе!**

**Для получения актуальной стоимости, обращайтесь по контактам, указанным ниже.**

kemmler@kemmler.su  
www.kemmler.su



**Гewindeschneid-Schnellwechselfutter MAS/BT (JIS B 6339) mit Längenausgleich auf Druck und Zug im Holzkasten inkl. Einsätze mit Rutschkupplung**

Quick-change tapping chucks MAS/BT (JIS B 6339) with length compensation in a wooden box incl. tapping collets with clutch  
Mandrin de taraudage MAS/BT (JIS B 6339) avec compensation longitudinale dans coffret en bois incl. douilles avec limiteur de couple

Bestell Nr. Order no. / Réf.	Abmessung Size / Dimension	Größe Size/ Taille	Stück Pcs.	Euro
405.16.12.SR	BT 40 - M3 / M14	Gr. 1	8	496,00
405.16.20.SR	BT 40 - M5 / M22	Gr. 2	10	724,00
505.16.12.SR	BT 50 - M3 / M14	Gr. 1	8	540,00
505.16.20.SR	BT 50 - M5 / M22	Gr. 2	10	768,00



**Гewindeschneid-Schnellwechselfutter MAS/BT (JIS B 6339) mit Längenausgleich auf Druck und Zug im Holzkasten inkl. Einsätze ohne Rutschkupplung**

Quick-change tapping chucks MAS/BT (JIS B 6339) with length compensation in a wooden box incl. tapping collets without clutch  
Mandrin de taraudage MAS/BT (JIS B 6339) avec compensation longitudinale dans coffret en bois incl. douilles sans limiteur de couple

Bestell Nr. Order no. / Réf.	Abmessung Size / Dimension	Größe Size/ Taille	Stück Pcs.	Euro
405.16.12.S	BT 40 - M3 / M14	Gr. 1	7	438,00
405.16.20.S	BT 40 - M5 / M22	Gr. 2	9	438,00
505.16.12.S	BT 50 - M3 / M14	Gr. 1	7	373,00
505.16.20.S	BT 50 - M5 / M22	Gr. 2	9	482,00



**Еinsätze mit Rutschkupplung**

Tapping collets with clutch  
Douilles avec limiteur de couple



**Еinsätze ohne Rutschkupplung**

Tapping collets without clutch  
Douilles sans limiteur de couple

Abmessung Size / Dimension	Abmessung Size / Dimension
Gr. 1 M3 - 3,5 × 2,7 DIN 371	Gr. 2 M5 - 6 × 4,9 DIN 371
Gr. 1 M4 - 4,5 × 3,4 DIN 371	Gr. 2 M6 - 6 × 4,9 DIN 371
Gr. 1 M5 - 6 × 4,9 DIN 371	Gr. 2 M8 - 8 × 6,2 DIN 371
Gr. 1 M6 - 6 × 4,9 DIN 371	Gr. 2 M10 - 10 × 8 DIN 371
Gr. 1 M8 - 8 × 6,2 DIN 371	Gr. 2 M12 - 9 × 7 DIN 376
Gr. 1 M10 - 10 × 8 DIN 371	Gr. 2 M14 - 11 × 9 DIN 376
Gr. 1 M12 - 9 × 7 DIN 376	Gr. 2 M16 - 12 × 9 DIN 376
Gr. 1 M14 - 11 × 9 DIN 376	Gr. 2 M18 - 14 × 11 DIN 376
	Gr. 2 M20 - 16 × 12 DIN 376
	Gr. 2 M22 - 18 × 14,5 DIN 376

Abmessung Size / Dimension	Abmessung Size / Dimension
Gr. 1 3,5 × 2,7	Gr. 2 6 × 4,9
Gr. 1 4,5 × 3,4	Gr. 2 8 × 6,2
Gr. 1 6 × 4,9	Gr. 2 9 × 7
Gr. 1 8 × 6,2	Gr. 2 10 × 8
Gr. 1 9 × 7	Gr. 2 11 × 9
Gr. 1 10 × 8	Gr. 2 12 × 9
Gr. 1 11 × 9	Gr. 2 14 × 11
	Gr. 2 16 × 12
	Gr. 2 18 × 14,5



**Внимание! Данный прайс-лист для европейского рынка.**  
Цены в РФ значительно отличаются от цен, указанных в данном документе!  
Для получения актуальной стоимости, обращайтесь по контактам, указанным ниже.





**Гewindeschneid-Schnellwechselfutter  
DIN 69893 A mit Längenausgleich  
auf Druck und Zug im Holzkasten  
inkl. Einsätze mit Rutschkupplung**

*Quick-change tapping chucks DIN 69893 A  
with length compensation in a wooden box  
incl. tapping collets with clutch*

Mandrin de taraudage DIN 69893 A  
avec compensation longitudinale dans coffret  
en bois incl. douilles avec limiteur de couple

Bestell Nr. <i>Order no. / Réf.</i>	Abmessung <i>Size / Dimension</i>	Größe <i>Size / Taille</i>	Stück <i>Pcs.</i>	Euro
A63.16.12.SR	HSK 63 - M3 / M14	Gr. 1	8	643,00
A63.16.20.SR	HSK 63 - M5 / M22	Gr. 2	10	891,00
A100.16.12.SR	HSK 100 - M3 / M14	Gr. 1	8	763,00
A100.16.20.SR	HSK 100 - M5 / M22	Gr. 2	10	1024,00



**Гewindeschneid-Schnellwechselfutter  
DIN 69893 A mit Längenausgleich  
auf Druck und Zug im Holzkasten  
inkl. Einsätze ohne Rutschkupplung**

*Quick-change tapping chucks DIN 69893 A  
with length compensation in a wooden box  
incl. tapping collets without clutch*

Mandrin de taraudage DIN 69893 A  
avec compensation longitudinale dans coffret  
en bois incl. douilles sans limiteur de couple

Bestell Nr. <i>Order no. / Réf.</i>	Abmessung <i>Size / Dimension</i>	Größe <i>Size / Taille</i>	Stück <i>Pcs.</i>	Euro
A63.16.12.S	HSK 63 - M3 / M14	Gr. 1	7	476,00
A63.16.20.S	HSK 63 - M5 / M22	Gr. 2	9	582,00
A100.16.12.S	HSK 100 - M3 / M14	Gr. 1	7	596,00
A100.16.20.S	HSK 100 - M5 / M22	Gr. 2	9	615,00



**Еinsätze mit Rutschkupplung**

*Tapping collets with clutch*  
Douilles avec limiteur de couple



**Еinsätze ohne Rutschkupplung**

*Tapping collets without clutch*  
Douilles sans limiteur de couple

Abmessung <i>Size / Dimension</i>	Abmessung <i>Size / Dimension</i>
Gr. 1 M3 - 3,5 × 2,7 DIN 371	Gr. 2 M5 - 6 × 4,9 DIN 371
Gr. 1 M4 - 4,5 × 3,4 DIN 371	Gr. 2 M6 - 6 × 4,9 DIN 371
Gr. 1 M5 - 6 × 4,9 DIN 371	Gr. 2 M8 - 8 × 6,2 DIN 371
Gr. 1 M6 - 6 × 4,9 DIN 371	Gr. 2 M10 - 10 × 8 DIN 371
Gr. 1 M8 - 8 × 6,2 DIN 371	Gr. 2 M12 - 9 × 7 DIN 376
Gr. 1 M10 - 10 × 8 DIN 371	Gr. 2 M14 - 11 × 9 DIN 376
Gr. 1 M12 - 9 × 7 DIN 376	Gr. 2 M16 - 12 × 9 DIN 376
Gr. 1 M14 - 11 × 9 DIN 376	Gr. 2 M18 - 14 × 11 DIN 376
	Gr. 2 M20 - 16 × 12 DIN 376
	Gr. 2 M22 - 18 × 14,5 DIN 376

Abmessung <i>Size / Dimension</i>	Abmessung <i>Size / Dimension</i>
Gr. 1 3,5 × 2,7	Gr. 2 6 × 4,9
Gr. 1 4,5 × 3,4	Gr. 2 8 × 6,2
Gr. 1 6 × 4,9	Gr. 2 9 × 7
Gr. 1 8 × 6,2	Gr. 2 10 × 8
Gr. 1 9 × 7	Gr. 2 11 × 9
Gr. 1 10 × 8	Gr. 2 12 × 9
Gr. 1 11 × 9	Gr. 2 14 × 11
	Gr. 2 16 × 12
	Gr. 2 18 × 14,5

**Внимание! Данный прайс-лист для европейского рынка.**

Цены в РФ значительно отличаются от цен, указанных в данном документе!

Для получения актуальной стоимости, обращайтесь по контактам, указанным ниже.

kemmler@kemmler.su  
www.kemmler.su



**Gewindeschneid-Schnellwechselfutter  
DIN 69880 mit Längenausgleich  
auf Druck und Zug im Holzkasten  
inkl. Einsätze mit Rutschkupplung**

Quick-change tapping chucks DIN 69880 with  
length compensation  
in a wooden box incl. tapping collets with clutch  
Mandrin de taraudage DIN 69880  
avec compensation longitudinale dans coffret en  
bois incl. douilles avec limiteur de couple

Bestell Nr. Order no. / Réf.	Abmessung Size / Dimension	Größe Size/ Taille	Stück Pcs.	Euro
309.16.12.SR	VDI 30 - M3 / M14	Gr. 1	8	540,00
309.16.20.SR	VDI 30 - M5 / M22	Gr. 2	10	829,00
409.16.12.SR	VDI 40 - M3 / M14	Gr. 1	8	569,00
409.16.20.SR	VDI 40 - M5 / M22	Gr. 2	10	835,00



**Gewindeschneid-Schnellwechselfutter  
DIN 69880 mit Längenausgleich  
auf Druck und Zug im Holzkasten  
inkl. Einsätze ohne Rutschkupplung**

Quick-change tapping chucks DIN 69880  
with length compensation in a wooden box  
incl. tapping collets without clutch  
Mandrin de taraudage DIN 69880  
avec compensation longitudinale dans coffret  
en bois incl. douilles sans limiteur de couple

Bestell Nr. Order no. / Réf.	Abmessung Size / Dimension	Größe Size/ Taille	Stück Pcs.	Euro
309.16.12.S	VDI 30 - M3 / M14	Gr. 1	7	373,00
309.16.20.S	VDI 30 - M5 / M22	Gr. 2	9	543,00
409.16.12.S	VDI 40 - M3 / M14	Gr. 1	7	402,00
409.16.20.S	VDI 40 - M5 / M22	Gr. 2	9	550,00



**Einsätze mit Rutschkupplung**

Tapping collets with clutch  
Douilles avec limiteur de couple



**Einsätze ohne Rutschkupplung**

Tapping collets without clutch  
Douilles sans limiteur de couple



Abmessung Size / Dimension	Abmessung Size / Dimension
Gr. 1 M3 - 3,5 × 2,7 DIN 371	Gr. 2 M5 - 6 × 4,9 DIN 371
Gr. 1 M4 - 4,5 × 3,4 DIN 371	Gr. 2 M6 - 6 × 4,9 DIN 371
Gr. 1 M5 - 6 × 4,9 DIN 371	Gr. 2 M8 - 8 × 6,2 DIN 371
Gr. 1 M6 - 6 × 4,9 DIN 371	Gr. 2 M10 - 10 × 8 DIN 371
Gr. 1 M8 - 8 × 6,2 DIN 371	Gr. 2 M12 - 9 × 7 DIN 376
Gr. 1 M10 - 10 × 8 DIN 371	Gr. 2 M14 - 11 × 9 DIN 376
Gr. 1 M12 - 9 × 7 DIN 376	Gr. 2 M16 - 12 × 9 DIN 376
Gr. 1 M14 - 11 × 9 DIN 376	Gr. 2 M18 - 14 × 11 DIN 376
	Gr. 2 M20 - 16 × 12 DIN 376
	Gr. 2 M22 - 18 × 14,5 DIN 376

Abmessung Size / Dimension	Abmessung Size / Dimension
Gr. 1 3,5 × 2,7	Gr. 2 6 × 4,9
Gr. 1 4,5 × 3,4	Gr. 2 8 × 6,2
Gr. 1 6 × 4,9	Gr. 2 9 × 7
Gr. 1 8 × 6,2	Gr. 2 10 × 8
Gr. 1 9 × 7	Gr. 2 11 × 9
Gr. 1 10 × 8	Gr. 2 12 × 9
Gr. 1 11 × 9	Gr. 2 14 × 11
	Gr. 2 16 × 12
	Gr. 2 18 × 14,5

Внимание! Данный прайс-лист для европейского рынка.  
Цены в РФ значительно отличаются от цен, указанных в данном документе!  
Для получения актуальной стоимости, обращайтесь по контактам, указанным ниже.



**Гewindeschneid-Schnellwechselfutter  
DIN 228-1B mit Längenausgleich  
auf Druck und Zug im Holzkasten  
inkl. Einsätze mit Rutschkupplung**

*Quick-change tapping chucks DIN 228-1B  
with length compensation in a wooden box  
incl. tapping collets with clutch*

Mandrin de taraudage DIN 228-1B  
avec compensation longitudinale dans coffret  
en bois incl. douilles avec limiteur de couple

Bestell Nr. <i>Order no. / Réf.</i>	Abmessung <i>Size / Dimension</i>	Größe <i>Size/ Taille</i>	Stück <i>Pcs.</i>	Euro
107.16.212.SR	MK 2 - M3 / M14	Gr. 1	8	452,00
107.16.320.SR	MK 3 - M5 / M22	Gr. 2	10	712,00



**Гewindeschneid-Schnellwechselfutter  
DIN 228-1B mit Längenausgleich auf  
Druck und Zug im Holzkasten  
inkl. Einsätze ohne Rutschkupplung**

*Quick-change tapping chucks DIN 228-1B  
with length compensation in a wooden box  
incl. tapping collets without clutch*

Mandrin de taraudage DIN 228-1B avec  
compensation longitudinale dans coffret en  
bois incl. douilles sans limiteur de couple

Bestell Nr. <i>Order no. / Réf.</i>	Abmessung <i>Size / Dimension</i>	Größe <i>Size/ Taille</i>	Stück <i>Pcs.</i>	Euro
107.16.212.S	MK 2- M3 / M14	Gr. 1	7	285,00
107.16.320.S	MK 3 - M5 / M22	Gr. 2	9	427,00



**Еinsätze mit Rutschkupplung**

*Tapping collets with clutch*  
Douilles avec limiteur de couple



**Еinsätze ohne Rutschkupplung**

*Tapping collets without clutch*  
Douilles sans limiteur de couple

Abmessung <i>Size / Dimension</i>		
Gr. 1	M3 - 3,5 × 2,7	DIN 371
Gr. 1	M4 - 4,5 × 3,4	DIN 371
Gr. 1	M5 - 6 × 4,9	DIN 371
Gr. 1	M6 - 6 × 4,9	DIN 371
Gr. 1	M8 - 8 × 6,2	DIN 371
Gr. 1	M10 - 10 × 8	DIN 371
Gr. 1	M12 - 9 × 7	DIN 376
Gr. 1	M14 - 11 × 9	DIN 376
Gr. 2	M5 - 6 × 4,9	DIN 371
Gr. 2	M6 - 6 × 4,9	DIN 371
Gr. 2	M8 - 8 × 6,2	DIN 371
Gr. 2	M10 - 10 × 8	DIN 371
Gr. 2	M12 - 9 × 7	DIN 376
Gr. 2	M14 - 11 × 9	DIN 376
Gr. 2	M16 - 12 × 9	DIN 376
Gr. 2	M18 - 14 × 11	DIN 376
Gr. 2	M20 - 16 × 12	DIN 376
Gr. 2	M22 - 18 × 14,5	DIN 376

Abmessung <i>Size / Dimension</i>	
Gr. 1	3,5 × 2,7
Gr. 1	4,5 × 3,4
Gr. 1	6 × 4,9
Gr. 1	8 × 6,2
Gr. 1	9 × 7
Gr. 1	10 × 8
Gr. 1	11 × 9
Gr. 2	6 × 4,9
Gr. 2	8 × 6,2
Gr. 2	9 × 7
Gr. 2	10 × 8
Gr. 2	11 × 9
Gr. 2	12 × 9
Gr. 2	14 × 11
Gr. 2	16 × 12
Gr. 2	18 × 14,5

**Внимание! Данный прайс-лист для европейского рынка.**

Цены в РФ значительно отличаются от цен, указанных в данном документе!

Для получения актуальной стоимости, обращайтесь по контактам, указанным ниже.

kemmler@kemmler.su  
www.kemmler.su



**Gewindeschneid-Schnellwechselfutter  
Zylinderschaft DIN 1835 B+E mit  
Längenausgleich auf Druck und Zug im  
Holzkasten inkl. Einsätze mit Rutschkupplung**

*Quick-change tapping chucks straight shank  
DIN 1835 B+E with length compensation  
in a wooden box incl. tapping collets with clutch*  
Mandrin de taraudage pour queues cylindriques  
straight shank DIN 1835 B+E avec compensation  
longitudinale dans coffret en bois incl. douilles  
avec limiteur de couple

Bestell Nr. Order no. / Réf.	Abmessung Size / Dimension	Größe Size/ Taille	Stück Pcs.	Euro
120.16.2012.SR	20 - M3 / M14	Gr. 1	8	452,00
120.16.2020.SR	20 - M5 / M22	Gr. 2	10	712,00



**Gewindeschneid-Schnellwechselfutter  
Zylinderschaft DIN 1835 B+E mit  
Längenausgleich auf Druck und Zug im  
Holzkasten inkl. Einsätze ohne Rutschkupplung**

*Quick-change tapping chucks straight shank  
DIN 1835 B+E with length compensation in a wooden  
box incl. tapping collets without clutch*  
Mandrin de taraudage pour queues cylindriques  
straight shank DIN 1835 B+E avec compensation  
longitudinale dans coffret en bois incl. douilles  
sans limiteur de couple

Bestell Nr. Order no. / Réf.	Abmessung Size / Dimension	Größe Size/ Taille	Stück Pcs.	Euro
120.16.2012.S	20 - M3 / M14	Gr. 1	8	285,00
120.16.2020.S	20 - M5 / M22	Gr. 2	10	427,00



**Einsätze mit Rutschkupplung**

*Tapping collets with clutch*  
Douilles avec limiteur de couple



**Einsätze ohne Rutschkupplung**

*Tapping collets without clutch*  
Douilles sans limiteur de couple



Abmessung Size / Dimension	Abmessung Size / Dimension
Gr. 1 M3 - 3,5 × 2,7 DIN 371	Gr. 2 M5 - 6 × 4,9 DIN 371
Gr. 1 M4 - 4,5 × 3,4 DIN 371	Gr. 2 M6 - 6 × 4,9 DIN 371
Gr. 1 M5 - 6 × 4,9 DIN 371	Gr. 2 M8 - 8 × 6,2 DIN 371
Gr. 1 M6 - 6 × 4,9 DIN 371	Gr. 2 M10 - 10 × 8 DIN 371
Gr. 1 M8 - 8 × 6,2 DIN 371	Gr. 2 M12 - 9 × 7 DIN 376
Gr. 1 M10 - 10 × 8 DIN 371	Gr. 2 M14 - 11 × 9 DIN 376
Gr. 1 M12 - 9 × 7 DIN 376	Gr. 2 M16 - 12 × 9 DIN 376
Gr. 1 M14 - 11 × 9 DIN 376	Gr. 2 M18 - 14 × 11 DIN 376
	Gr. 2 M20 - 16 × 12 DIN 376
	Gr. 2 M22 - 18 × 14,5 DIN 376

Abmessung Size / Dimension	Abmessung Size / Dimension
Gr. 1 3,5 × 2,7	Gr. 2 6 × 4,9
Gr. 1 4,5 × 3,4	Gr. 2 8 × 6,2
Gr. 1 6 × 4,9	Gr. 2 9 × 7
Gr. 1 8 × 6,2	Gr. 2 10 × 8
Gr. 1 9 × 7	Gr. 2 11 × 9
Gr. 1 10 × 8	Gr. 2 12 × 9
Gr. 1 11 × 9	Gr. 2 14 × 11
	Gr. 2 16 × 12
	Gr. 2 18 × 14,5

**Внимание! Данный прайс-лист для европейского рынка.**  
Цены в РФ значительно отличаются от цен, указанных в данном документе!  
Для получения актуальной стоимости, обращайтесь по контактам, указанным ниже.



## Гвиндебоhrerhalter

Tap Holders  
Porte-tarauds

### Гвиндеbohrer-Spannhülsen für Fräseraufnahmen DIN 1835 B mit Schnellwechsel-Kupplung

Clamping sleeves for taps in end mill holders DIN 1835 B with quick change adaptor

Douilles de serrage à changement rapide pour tarauds dans de porte-fraises DIN 1835 B

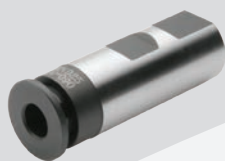

Bestell-Nr. Order no. / Référence	Abmessung Size / Dimension	Euro
16.16.3527	16 - 3,5 × 2,7	31,00
16.16.4030	16 - 4,0 × 3,0	31,00
16.16.4534	16 - 4,5 × 3,4	31,00
16.16.649	16 - 6,0 × 4,9	31,00
16.20.4534	20 - 4,5 × 3,4	31,00
16.20.649	20 - 6,0 × 4,9	31,00
16.20.862	20 - 8,0 × 6,2	31,00
16.20.755	20 - 7,0 × 5,5	31,00
16.20.108	20 - 10,0 × 8,0	31,00
16.20.97	20 - 9,0 × 7,0	31,00
16.25.4534	25 - 4,5 × 3,4	44,00
16.25.649	25 - 6,0 × 4,9	44,00
16.25.755	25 - 7,0 × 5,5	44,00
16.25.862	25 - 8,0 × 6,2	44,00
16.25.97	25 - 9,0 × 7,0	44,00
16.25.108	25 - 10,0 × 8,0	44,00
16.25.119	25 - 11,0 × 9,0	44,00
16.25.129	25 - 12,0 × 9,0	44,00
16.32.649	32 - 6,0 × 4,9	48,00
16.32.755	32 - 7,0 × 5,5	48,00
16.32.862	32 - 8,0 × 6,2	48,00
16.32.97	32 - 9,0 × 7,0	48,00
16.32.108	32 - 10,0 × 8,0	48,00
16.32.119	32 - 11,0 × 9,0	48,00
16.32.129	32 - 12,0 × 9,0	48,00
16.32.1411	32 - 14,0 × 11,0	48,00
16.32.1612	32 - 16,0 × 12,0	48,00
16.32.18145	32 - 18,0 × 14,5	48,00

### Гвиндеbohrer-Spannhülsen für Fräseraufnahmen DIN 1835 B

Clamping sleeves for taps in end mill holders DIN 1835 B

Douilles de serrage pour tarauds dans de porte-fraises DIN 1835 B



Bestell-Nr. Order no. / Référence	Abmessung Size / Dimension	Euro
704.04.0825	8 - 2,5 × 2,1	46,00
704.04.0828	8 - 2,8 × 2,1	46,00
704.04.1035	10 - 3,5 × 2,7	46,00
704.04.1040	10 - 4,0 × 3,0	46,00
704.04.1045	10 - 4,5 × 3,4	46,00
704.04.1260	12 - 6,0 × 4,9	36,00
704.04.1470	14 - 7,0 × 5,5	36,00
704.04.1480	14 - 8,0 × 6,2	36,00
704.04.1690	16 - 9,0 × 7,0	36,00
704.04.1610	16 - 10,0 × 8,0	36,00
704.04.1811	18 - 11,0 × 9,0	36,00
704.04.2012	20 - 12,0 × 9,0	36,00
704.04.2514	25 - 14,0 × 11,0	40,00
704.04.2516	25 - 16,0 × 12,0	40,00
704.04.3216	32 - 16,0 × 12,0	47,00
704.04.3218	32 - 18,0 × 14,5	47,00
704.04.3220	32 - 20,0 × 16,0	47,00
704.04.3222	32 - 22,0 × 18,0	47,00
704.04.4025	40 - 25,0 × 20,0	62,00
704.04.4028	40 - 28,0 × 22,0	71,00
704.04.5032	50 - 32,0 × 24,0	71,00
704.04.5036	50 - 36,0 × 29,0	89,00
704.04.5040	50 - 40,0 × 32,0	89,00



Внимание! Данный прайс-лист для европейского рынка.

Цены в РФ значительно отличаются от цен, указанных в данном документе!

Для получения актуальной стоимости, обращайтесь по контактам, указанным ниже.

kemmler@kemmler.su  
www.kemmler.su



**Zubehör**  
Accessories  
Accessoires



**Fräseranzugschrauben DIN 6367**  
Retaining screws DIN 6367  
Vis de serrage DIN 6367

Bestell-Nr. Order no. / Référence	Abmessung Size / Dimension	Euro
102.10.16	M8	4,00
102.10.22	M10	4,00
102.10.27	M12	6,00
102.10.32	M16	8,00
102.10.40	M20	12,00
102.10.50	M24	25,00
102.10.60	M30	39,00



**Fräseranzugschrauben DIN 6367 durchbohrt für Kühlmittelzufuhr**  
Retaining screws DIN 6367 with drill through for coolant  
Vis de serrage DIN 6367 percée pour l'arrosage

Bestell-Nr. Order no. / Référence	Abmessung Size / Dimension	Euro
102.11.16	M8	8,00
102.11.22	M10	8,00
102.11.27	M12	9,00
102.11.32	M16	13,00
102.11.40	M20	17,00
102.11.50	M24	26,00
102.11.60	M30	47,00



**Mitnehmerringe DIN 6366**  
Clutch drive rings DIN 6366  
Bagues d'entraînement DIN 6366

Bestell-Nr. Order no. / Référence	Abmessung Size / Dimension	Euro
101.10.16	16	8,00
101.10.22	22	10,00
101.10.27	27	10,00
101.10.32	32	13,00
101.10.40	40	15,00

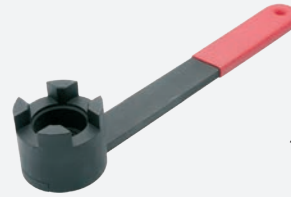

**Spann Schlüssel DIN 6368 für Aufsteckdorne**  
Wrenches DIN 6368 for shell arbors  
Clés de serrage DIN 6368 pour broches creuses

Bestell-Nr. Order no. / Référence	Abmessung Size / Dimension	Euro
10.16	16 / M8	13,00
10.22	22 / M10	16,00
10.27	27 / M12	19,00
10.32	32 / M16	24,00
10.40	40 / M20	33,00



**Spannschrauben für Weldon Spannfutter DIN 1835 B**  
Clamping screws for Weldon chucks DIN 1835 B  
Vis de serrage pour mandrins Weldon DIN 1835 B

Bestell-Nr. Order no. / Référence	Abmessung Size / Dimension	Euro
101.04.06	M6	3,00
101.04.08	M8	3,00
101.04.10	M10	3,00
101.04.12	M12	4,00
101.04.16	M14	4,00
101.04.20	M16	4,00
101.04.25	M18 × 2	7,00
101.04.32	M20 × 2 × 20	7,00
101.04.40	M20 × 2 × 25	7,00



**Passfeder**  
Feather keys  
Ressort de passage

Bestell-Nr. Order no. / Référence	Abmessung Size / Dimension	Euro
101.10.16K	4x6x20	3,00
101.10.22K	6x6x25	3,00
101.10.27K	7x7x25	4,00
101.10.32K	8x7x28	5,00
101.10.40K	10x8x32	6,00



Внимание! Данный прайс-лист для европейского рынка.  
Цены в РФ значительно отличаются от цен, указанных в данном документе!  
Для получения актуальной стоимости, обращайтесь по контактам, указанным ниже.



**Zubehör**  
Accessories  
Accessoires



**Montageblöcke aus Aluminium**  
Tightening fixtures made of aluminium  
Blocs de montage en aluminium

Bestell-Nr. Order no. / Référence	Abmessung Size / Dimension	Euro
700.30	SK 30	101,00
700.40	SK 40	101,00
700.50	SK 50	157,00



**Montageblock universal mit Kugellager**  
Universal ball bearing tightening fixture  
Bloc de montage universel avec palier à billes

Bestell-Nr. Order no. / Référence	Abmessung Size / Dimension	Euro
706.63	HSK63 - SK40 - BT40 - CAT40 - C6	209,00



**Kegelwischer**  
Taper wipers  
Nettoies cônes

Bestell-Nr. Order no. / Référence	Abmessung Size / Dimension	Euro
710.01.415	OZ 16	20,00
710.01.462	OZ 25	25,00
710.01.467	OZ 32	29,00
710.02.426	ER 16	15,00
710.02.430	ER 25	20,00
710.02.470	ER 32	25,00
710.02.472	ER 40	28,00
710.01	MK 1	8,00
710.02	MK 2	8,00
710.03	MK 3	9,00
710.04	MK 4	12,00
710.05	MK 5	14,00



**Montageblöcke aus Stahl, schwenkbar**  
Universal assembly blocks made of steel, pivoted  
Blocs de montage universels en acier, pivotant

Bestell-Nr. Order no. / Référence	Abmessung Size / Dimension	Euro
705.30	SK 30	167,00
705.40	SK 40	167,00
705.50	SK 50	200,00
708.32	HSK 32	191,00
708.40	HSK 40	191,00
708.50	HSK 50	191,00
708.63	HSK 63	213,00
708.80	HSK 80	235,00
708.10	HSK 100	235,00
709.16	VDI 16	191,00
709.20	VDI 20	191,00
709.30	VDI 30	191,00
709.40	VDI 40	191,00
709.50	VDI 50	213,00



**Kegelwischer**  
Taper wipers  
Nettoies cônes

Bestell-Nr. Order no. / Référence	Abmessung Size / Dimension	Euro
710.30	SK 30	11,00
710.40	SK 40	12,00
710.50	SK 50	17,00
710.32.HSK	HSK 32 Form A-C-E	42,00
710.40.HSK	HSK 40 Form A-C-E	42,00
710.50.HSK	HSK 50 Form A-C-E	45,00
710.63.HSK	HSK 63 Form A-C-E	45,00
710.80.HSK	HSK 80 Form A-C-E	52,00
710.100.HSK	HSK 100 Form A-C-E	61,00
710.63.HSK.F	HSK 63 Form F	49,00

Внимание! Данный прайс-лист для европейского рынка.

Цены в РФ значительно отличаются от цен, указанных в данном документе!

Для получения актуальной стоимости, обращайтесь по контактам, указанным ниже.

kemmler@kemmler.su  
www.kemmler.su



**Zubehör**  
Accessories  
Accessoires



**Reduziereinsätze DIN 1835 B für Zylinderschäfte DIN 1835 B+E**  
*Reducing bushes DIN 1835 B for tool shanks DIN 1835 B+E*  
Réductions DIN 1835 B pour queues cylindriques DIN 1835 B+E

Bestell-Nr. Order no. / Référence	Abmessung Size / Dimension	Euro
122.20.06	20 - 06	36,00
122.20.08	20 - 08	33,00
122.20.10	20 - 10	33,00
122.20.12	20 - 12	33,00

122.32.06	32 - 06	44,00
122.32.08	32 - 08	40,00
122.32.10	32 - 10	40,00
122.32.12	32 - 12	40,00
122.32.14	32 - 14	40,00
122.32.16	32 - 16	40,00
122.32.18	32 - 18	40,00
122.32.20	32 - 20	40,00



**Schrumpfverlängerungen (mit Anschlag)**  
*Shrink fit extensions (with end stop)*  
Rallonges de frettage (avec butée)

Bestell-Nr. Order no. / Référence	Abmessung Size / Dimension	Euro
120.70.03	20 - 03 - 150	123,00
120.70.04	20 - 04 - 150	123,00
120.70.05	20 - 05 - 150	123,00
120.70.06	20 - 06 - 150	123,00
120.70.08	20 - 08 - 150	123,00
120.70.10	20 - 10 - 150	123,00
120.70.12	20 - 12 - 150	123,00



**Hydro-Dehnspannfutter mit Zylinderschaft**  
*Hydraulic expansion chucks for tool shanks*  
Mandrins expansibles hydrauliques pour queues cylindriques

Bestell-Nr. Order no. / Référence	Abmessung Size / Dimension	Euro
120.H12.12	12 - 12 - 100	628,00
120.H20.12	20 - 12 - 100	628,00
120.H20.16	20 - 16 - 100	628,00
120.H20.20	20 - 20 - 100	628,00
120.H32.12	32 - 12 - 140	628,00
120.H32.16	32 - 16 - 140	628,00
120.H32.20	32 - 20 - 140	628,00



**Präzisions-Schnellspann-Bohrfutter für Bohrfutteraufnahmen DIN 238**  
*Precision rapid clamping drill chucks for drill chuck adaptors DIN 238*  
Mandrins de perçage précis à serrage rapide pour arbres DIN 238

Bestell-Nr. Order no. / Référence	Abmessung Size / Dimension	Euro
14.08.B12	0,3 / 8 - B12	86,00
14.13.B16	0,5 / 13 - B16	84,00
14.16.B16	3,0 / 16 - B16	105,00



**CNC-Bohrfutter für Bohrfutteraufnahmen DIN 238**  
*CNC-Drill chucks for drill chuck adaptors DIN 238*  
Mandrins de perçage CNC pour arbres DIN 238

Bestell-Nr. Order no. / Référence	Abmessung Size / Dimension	Euro
15.08.B12	0,5 / 8 - B12	279,00
15.13.B16	1,0 / 13 - B16	235,00
15.16.B16	2,5 / 16 - B16	257,00



**CNC-Bohrfutter mit Zylinderschaft DIN 1835 B**  
*CNC-Drill chucks with straight shank DIN 1835 B*  
Mandrins de perçage CNC à queue cylindrique DIN 1835 B

Bestell-Nr. Order no. / Référence	Abmessung Size / Dimension	Euro
120.15.2013	20 - 1,0 / 13 - 143	242,00
120.15.2016	20 - 2,5 / 16 - 148	247,00



**CNC-Bohrfutter mit MK**  
*CNC-Drill chucks with MT*  
Mandrins de perçage CNC avec CM

Bestell-Nr. Order no. / Référence	Abmessung Size / Dimension	Euro
107.15.313	MK 3 - 1,0 / 13 - 98	252,00
107.15.316	MK 3 - 2,5 / 16 - 103	258,00
107.15.413	MK 4 - 1,0 / 13 - 100	263,00
107.15.416	MK 4 - 2,5 / 16 - 105	268,00



**Внимание! Данный прайс-лист для европейского рынка.**  
Цены в РФ значительно отличаются от цен, указанных в данном документе!  
Для получения актуальной стоимости, обращайтесь по контактам, указанным ниже.



**Zubehör**  
Accessories  
Accessoires

**Spannfutter mit Zylinderschaft für Spannzangen DIN 6499 (ISO 15488) System ER**



*Collet chucks with straight shank for collets DIN 6499 (ISO 15488) ER-system*  
Mandrins à pinces à queue cylindrique pour pinces DIN 6499 (ISO 15488) système ER

Bestell-Nr. Order no. / Référence	Abmessung Size / Dimension	Euro
120.02.10	16 - 1 / 10 - 150 (ER 16)	48,00
120.02.16	20 - 2 / 16 - 150 (ER 25)	51,00
120.02.20	32 - 2 / 20 - 150 (ER 32)	55,00



**Spannfutter mit Zylinderschaft mit Spannfläche für Spannzangen DIN 6499 (ISO 15488) System ER**



*Collet chucks with straight shank with clamping surface for collets DIN 6499 (ISO 15488) ER-system*  
Mandrins à pinces à queue cylindrique avec surface de serrage pour pinces DIN 6499 (ISO 15488) système ER

Bestell-Nr. Order no. / Référence	Abmessung Size / Dimension	Euro
120.02.04.10	16 - 1 / 10 - 150 (ER 16)	65,00
120.02.04.16	20 - 2 / 16 - 150 (ER 25)	67,00
120.02.04.20	32 - 2 / 20 - 150 (ER 32)	73,00



**Spannfutter Zylinderschaft mit Minimutter**



*Collet chucks with straight shank with Mini nuts*  
Mandrins à pinces à queue cylindrique avec mini-écrous

Bestell-Nr. Order no. / Référence	Abmessung Size / Dimension	Euro
120.02.07	16 - 1 / 07 - 150 (ER 11)	80,00
120.02.10.1	20 - 1 / 10 - 150 (ER 16)	97,00



Внимание! Данный прайс-лист для европейского рынка.

Цены в РФ значительно отличаются от цен, указанных в данном документе!

Для получения актуальной стоимости, обращайтесь по контактам, указанным ниже.

**Zubehör**  
Accessories  
Accessoires



**Spannfutter mit Zylinderschaft für Spannzangen DIN 6499 (ISO 15488) System ER**

Collet chucks with straight shank for collets DIN 6499 (ISO 15488) ER-system  
Mandrins à pinces à queue cylindrique pour pinces DIN 6499 (ISO 15488) système ER

Bestell-Nr. Order no. / Référence	Abmessung Size / Dimension	Euro
120.02.A.07	20 - 1 / 07 - 67,50 (ER 11)	63,00
120.02.A.07.1	20 - 1 / 07 - 87,50 (ER 11)	63,00
120.02.A.10	20 - 1 / 10 - 96,50 (ER 16)	63,00
120.02.A.13	25 - 1 / 13 - 74 (ER 20)	63,00

**Sechskantmutter**  
Hexagonal clamping nut  
Écrous hexagonal



**Doppel-Spannzangenhalter mit Zylinderschaft für Spannzangen DIN 6499 (ISO 15488) System ER**

Double collet holder with straight shank for collets DIN 6499 (ISO 15488) ER-system  
Porte-pinces doubles à queue cylindrique pour pinces DIN 6499 (ISO 15488) système ER

Bestell-Nr. Order no. / Référence	Abmessung Size / Dimension	Euro
120.02.B.13	25 - 1 / 13 - 98 (ER 20)	86,00

**Sechskantmutter**  
Hexagonal clamping nut  
Écrous hexagonal



**Spannfutter Zylinderschaft mit Minimutter**

Collet chucks with straight shank with Mini nuts  
Mandrins à pinces à queue cylindrique avec mini-écrous

Bestell-Nr. Order no. / Référence	Abmessung Size / Dimension	Euro
120.02.C.10	20 - 1/10-76,50 (ER 16)	57,00

**Mit Minimutter**  
With mini nut  
Avec écrous-mini



**Doppel-Spannzangenhalter mit Zylinderschaft für Spannzangen DIN 6499 (ISO 15488) System ER**

Double collet holder with straight shank for collets DIN 6499 (ISO 15488) ER-system  
Porte-pinces doubles à queue cylindrique pour pinces DIN 6499 (ISO 15488) système ER

Bestell-Nr. Order no. / Référence	Abmessung Size / Dimension	Euro
120.02.D.10	20 - 1/10-123 (ER 16)	86,00

**Mit Minimutter**  
With mini nut  
Avec écrous-mini



Внимание! Данный прайс-лист для европейского рынка.  
Цены в РФ значительно отличаются от цен, указанных в данном документе!  
Для получения актуальной стоимости, обращайтесь по контактам, указанным ниже.





**Zubehör**  
Accessories  
Accessoires

**Reduzierungen für Hydrodehnspannfutter für Peripheriekühlung, Bund geschlitzt, nicht kühlmitteldicht**

*Reduction sleeves for hydraulic expansion chucks with peripheral cooling, collar slotted, not coolant proof*

*Douilles de réduction pour mandrins expansibles hydrauliques pour arrosage périphérique, collerette fendue, non étanche au liquide d'arrosage*



Bestell-Nr. Order no. / Référence	Abmessung Size / Dimension	Euro
R20.030	20 - 3	73,00
R20.040	20 - 4	73,00
R20.050	20 - 5	73,00
R20.060	20 - 6	63,00
R20.080	20 - 8	63,00
R20.100	20 - 10	63,00
R20.120	20 - 12	63,00
R20.140	20 - 14	63,00
R20.160	20 - 16	63,00
R32.060	32 - 6	79,00
R32.080	32 - 8	79,00
R32.100	32 - 10	79,00
R32.120	32 - 12	79,00
R32.140	32 - 14	79,00
R32.160	32 - 16	79,00
R32.180	32 - 18	79,00
R32.200	32 - 20	79,00
R32.250	32 - 25	79,00

**Reduzierungen für Hydrodehnspannfutter für innere Kühlmittelzufuhr, Bund geschlossen, kühlmitteldicht bis max. 80 bar**

*Reduction sleeves for hydraulic expansion chucks for internal coolant supply, closed collar, coolant proof up to max. 80 bar*

*Douilles de réduction pour mandrins expansibles hydrauliques avec arrosage centrale, collerette pleine, étanche au liquide d'arrosage jusqu'à 80 bar max.*



Bestell-Nr. Order no. / Référence	Abmessung Size / Dimension	Euro
RD20.030	20 - 3	95,00
RD20.040	20 - 4	95,00
RD20.050	20 - 5	95,00
RD20.060	20 - 6	72,00
RD20.080	20 - 8	72,00
RD20.100	20 - 10	72,00
RD20.120	20 - 12	72,00
RD20.140	20 - 14	72,00
RD20.160	20 - 16	72,00
RD32.030	32 - 3	111,00
RD32.040	32 - 4	111,00
RD32.050	32 - 5	111,00
RD32.060	32 - 6	100,00
RD32.080	32 - 8	100,00
RD32.100	32 - 10	100,00
RD32.120	32 - 12	100,00
RD32.140	32 - 14	100,00
RD32.160	32 - 16	100,00
RD32.180	32 - 18	100,00
RD32.200	32 - 20	100,00
RD32.250	32 - 25	100,00



Внимание! Данный прайс-лист для европейского рынка.

Цены в РФ значительно отличаются от цен, указанных в данном документе!

Для получения актуальной стоимости, обращайтесь по контактам, указанным ниже.

kemmler@kemmler.su  
www.kemmler.su

**Zubehör**  
Accessories  
Accessoires



**Hydro-Dehnspannfutter Ø 20 - DIN 69871 AD/B  
im Holzkasten und Reduzierungen**

*Hydraulic expansion chucks Ø 20 - DIN 69871 AD/B*

*Mandrins expansibles hydrauliques Ø 20 - DIN 69871 AD/B*

Bestell Nr. <i>Order no. / Réf.</i>	Abmessung <i>Size / Dimension</i>	Reduzierung <i>Reduction sleeves / Douilles de réduction</i>	Typ <i>Size/ Taille</i>	Euro
403.H20.R.S	SK 40 - 20 - 82	6 - 8 - 10 - 12 - 16	Nicht abgedichtet   <i>not sealed</i>   non étanche	667,00
403.H20.RD.S	SK 40 - 20 - 82	6 - 8 - 10 - 12 - 16	Abgedichtet   <i>sealed</i>   étanche	709,00
503.H20.R.S	SK 50 - 20 - 82	6 - 8 - 10 - 12 - 16	Nicht abgedichtet   <i>not sealed</i>   non étanche	779,00
503.H20.RD.S	SK 50 - 20 - 82	6 - 8 - 10 - 12 - 16	Abgedichtet   <i>sealed</i>   étanche	821,00



**Hydro-Dehnspannfutter Ø 20 - JIS B 6339 (MAS-BT) AD/B  
im Holzkasten und Reduzierungen**

*Hydraulic expansion chucks Ø 20 - JIS B 6339 (MAS-BT) AD/B*

*Mandrins expansibles hydrauliques Ø 20 - JIS B 6339 (MAS-BT) AD/B*

Bestell Nr. <i>Order no. / Réf.</i>	Abmessung <i>Size / Dimension</i>	Reduzierung <i>Reduction sleeves / Douilles de réduction</i>	Typ <i>Size/ Taille</i>	Euro
406.H20.R.S	BT 40 - 20 - 90	6 - 8 - 10 - 12 - 16	Nicht abgedichtet   <i>not sealed</i>   non étanche	667,00
406.H20.RD.S	BT 40 - 20 - 90	6 - 8 - 10 - 12 - 16	Abgedichtet   <i>sealed</i>   étanche	709,00
506.H20.R.S	BT 50 - 20 - 110	6 - 8 - 10 - 12 - 16	Nicht abgedichtet   <i>not sealed</i>   non étanche	779,00
506.H20.RD.S	BT 50 - 20 - 110	6 - 8 - 10 - 12 - 16	Abgedichtet   <i>sealed</i>   étanche	821,00



**Hydro-Dehnspannfutter Ø 20 - DIN 69893 Form A  
im Holzkasten und Reduzierungen**

*Hydraulic expansion chucks Ø 20 - DIN 69893 Form A*

*Mandrins expansibles hydrauliques Ø 20 - DIN 69893 Form A*

Bestell Nr. <i>Order no. / Réf.</i>	Abmessung <i>Size / Dimension</i>	Reduzierung <i>Reduction sleeves / Douilles de réduction</i>	Typ <i>Size/ Taille</i>	Euro
A63.H20.R.S	HSK 63 - 20 - 100	6 - 8 - 10 - 12 - 16	Nicht abgedichtet   <i>not sealed</i>   non étanche	683,00
A63.H20.RD.S	HSK 63 - 20 - 100	6 - 8 - 10 - 12 - 16	Abgedichtet   <i>sealed</i>   étanche	731,00
A100.H20.R.S	HSK 100 - 20 - 105	6 - 8 - 10 - 12 - 16	Nicht abgedichtet   <i>not sealed</i>   non étanche	798,00
A100.H20.RD.S	HSK 100 - 20 - 105	6 - 8 - 10 - 12 - 16	Abgedichtet   <i>sealed</i>   étanche	843,00

**Внимание! Данный прайс-лист для европейского рынка.**

**Цены в РФ значительно отличаются от цен, указанных в данном документе!**

**Для получения актуальной стоимости, обращайтесь по контактам, указанным ниже.**





**Zubehör**  
Accessories  
Accessoires



**Hartmetall Zentrierspitzen -  
DIN 806 HE - abgeflachte  
Ausführung mit Hartmetall-  
Einsatz**  
*Solid half point with carbide insert -  
DIN 806 HE*  
Demi-pointe fixe avec insert en  
métal dur - DIN 806 HE

Bestell-Nr. <i>Order no. / Référence</i>	Abmessung <i>Size / Dimension</i>	Euro
109.11.01	MK 1	24,00
109.11.02	MK 2	26,00
109.11.03	MK 3	35,00
109.11.04	MK 4	37,00
109.11.05	MK 5	45,00



**Mitlaufende Drehbankspitze  
mit verlängerter Spitze**  
*Revolving lathe centre with  
extended point*  
Pointe tournante allongée

Bestell-Nr. <i>Order no. / Référence</i>	Abmessung <i>Size / Dimension</i>	Euro
109.13.02	MK 2	69,00
109.13.03	MK 3	73,00
109.13.04	MK 4	90,00
109.13.05	MK 5	168,00



**Hartmetall Zentrierspitzen  
DIN 806 E - Volle Ausführung  
mit Hartmetall-Einsatz**  
*Solid lathe centre  
with carbide insert - DIN 806 E*  
Pointe fixe  
avec insert en métal dur - DIN 806 E

Bestell-Nr. <i>Order no. / Référence</i>	Abmessung <i>Size / Dimension</i>	Euro
109.12.01	MK 1	28,00
109.12.02	MK 2	30,00
109.12.03	MK 3	40,00
109.12.04	MK 4	58,00
109.12.05	MK 5	69,00



**Mitlaufende Drehbankspitze**  
*Revolving lathe centre*  
Pointe tournante

Bestell-Nr. <i>Order no. / Référence</i>	Abmessung <i>Size / Dimension</i>	Euro
109.14.01	MK 1	66,00
109.14.02	MK 2	67,00
109.14.03	MK 3	68,00
109.14.04	MK 4	83,00
109.14.05	MK 5	168,00



**Parallel-Unterlagen-Sätze**  
*Set of parallel supports*  
Jeu de supports parallèles

Bestell-Nr. <i>Order no. / Référence</i>	Ausführung <i>Version / Type</i>	Euro
91.12.150.1	14 x 2 - 150x10x14	200,00
91.12.150.2	14 x 2 - 150 x 8 x14	200,00
91.12.200.3	14 x 2 - 200x10x14	263,00
91.13.100.1	9 x 2 - 100x4x10	168,00



Внимание! Данный прайс-лист для европейского рынка.

Цены в РФ значительно отличаются от цен, указанных в данном документе!

Для получения актуальной стоимости, обращайтесь по контактам, указанным ниже.



### CNC-Werkzeugwagen inkl. Werkzeugaufnahmeträger

Trolley for CNC toolholders incl. tool carrier

Chariots pour porte-outils incl. support pour porte-outils

Bestell-Nr. Order no. / Référence	Abmessung Size / Dimension	Einsätze inserts / inserts	Euro
784.01.30*	SK 30	45	798,00
784.01.40*	SK 40	35	783,00
784.01.50*	SK 50	25	735,00
784.02.63*	HSK 63	30	751,00
784.02.100*	HSK 100	20	735,00



### CNC-Werkzeuggestell inkl. Werkzeugaufnahmeträger

Stand for CNC toolholders incl. tool carrier

Étagère pour porte-outils CNC incl. support pour porte-outils

Bestell-Nr. Order no. / Référence	Abmessung Size / Dimension	Einsätze inserts / inserts	Euro
782.01.30*	SK 30	72	914,00
782.01.40*	SK 40	56	893,00
782.01.50*	SK 50	40	809,00
782.02.63*	HSK 63	48	840,00
782.02.100*	HSK 100	32	809,00



### CNC-Werkzeugaufnahmeträger

Tool carrier for CNC toolholders

Support pour porte-outils CNC

Bestell-Nr. Order no. / Référence	Abmessung Size / Dimension	Einsätze inserts / inserts	Euro
781.01.30	SK 30	9	63,00
781.01.40	SK 40	7	62,00
781.01.50	SK 50	5	53,00
781.02.63	HSK 63	6	56,00
781.02.100	HSK 100	4	53,00

\*zzgl. Speditionskosten  
\*carrying costs in addition  
\*majoré de frais de transport

Внимание! Данный прайс-лист для европейского рынка.  
Цены в РФ значительно отличаются от цен, указанных в данном документе!  
Для получения актуальной стоимости, обращайтесь по контактам, указанным ниже.

kemmler@kemmler.su  
www.kemmler.su

KEMMLER

133





**CNC Werkzeugeinsätze**  
*Inserts for CNC toolholders*  
 Inserts pour porte-outils CNC

**System 2**

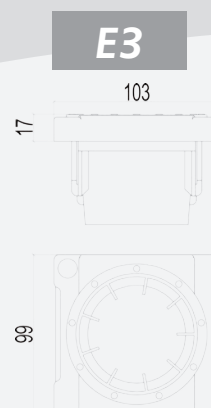
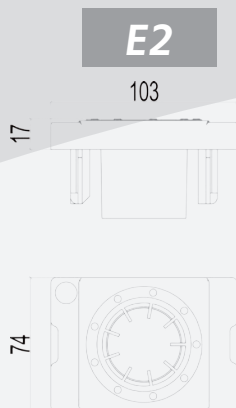
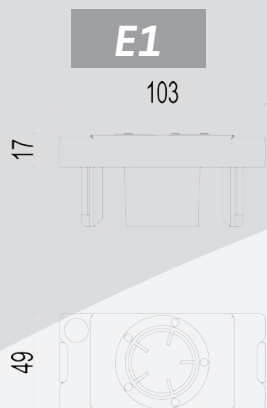

**E1**

Bestell-Nr. <i>Order no. / Référence</i>	Abmessung <i>Size / Dimension</i>	Euro
785.01.30	ISO / SK 30	11,00
785.02.30	VDI 30	11,00
785.03.30	MK 3	11,00
785.03.40	MK 4	11,00



**E2**

Bestell-Nr. <i>Order no. / Référence</i>	Abmessung <i>Size / Dimension</i>	Euro
785.01.40	SK 40	12,00
785.02.40	VDI 40	12,00
786.01.50	HSK A 50 / B63	17,00
786.01.63	HSK A 63 / B80	18,00
785.03.50	MK 5	12,00



**E3**

Bestell-Nr. <i>Order no. / Référence</i>	Abmessung <i>Size / Dimension</i>	Euro
785.01.50	ISO / SK 50	14,00
785.02.50	VDI 50	14,00
786.01.80	HSK A 80 / B100	19,00
786.01.100	HSK A 100 / B125	20,00



**E3**

Bestell-Nr. <i>Order no. / Référence</i>	Abmessung <i>Size / Dimension</i>	Euro
786.01.40	HSK A 40 / B 50	22,00



**E3**

Bestell-Nr. <i>Order no. / Référence</i>	Abmessung <i>Size / Dimension</i>	Euro
786.01.32	HSK A 32 / B 40	26,00

Внимание! Данный прайс-лист для европейского рынка.

Цены в РФ значительно отличаются от цен, указанных в данном документе!

Для получения актуальной стоимости, обращайтесь по контактам, указанным ниже.

kemmler@kemmler.su  
 www.kemmler.su





**CNC Werkzeugeinsätze**  
*Inserts for CNC toolholders*  
 Inserts pour porte-outils CNC

**System 2**



**E3**

Bestell-Nr. <i>Order no. / Référence</i>	Abmessung <i>Size / Dimension</i>	Euro
786.01.00	Universal	19,00



**E3**

Bestell-Nr. <i>Order no. / Référence</i>	Abmessung <i>Size / Dimension</i>	Euro
786.01.03	Capto C3	26,00



**E1**

Bestell-Nr. <i>Order no. / Référence</i>	Abmessung <i>Size / Dimension</i>	Euro
786.01.04	Capto C4	11,00



**E2**

Bestell-Nr. <i>Order no. / Référence</i>	Abmessung <i>Size / Dimension</i>	Euro
786.01.05	Capto C5	13,00



**E3**

Bestell-Nr. <i>Order no. / Référence</i>	Abmessung <i>Size / Dimension</i>	Euro
786.01.06	Capto C6	15,00



**E3**

Bestell-Nr. <i>Order no. / Référence</i>	Abmessung <i>Size / Dimension</i>	Euro
786.01.08	Capto C8	19,00

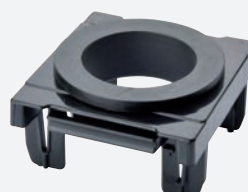

**Внимание!** Данный прайс-лист для европейского рынка.  
 Цены в РФ значительно отличаются от цен, указанных в данном документе!  
 Для получения актуальной стоимости, обращайтесь по контактам, указанным ниже.



**CNC Tischaufsatzgestelle**  
*Bench stand for CNC toolholders*  
 Étagère pour porte-outils CNC

**System 2**



**2 oder 4 Kassetten mit verschraubtem Korpus, Ablage und Haltegriffen (ohne Werkzeuge und Einsätze)**  
*2 or 4 magazines with bolted corpus, rack and handles (without toolholders and inserts)*  
 2 ou 4 cassettes avec corps vissé, support et poignées (sans outils et inserts)

Bestell-Nr.	Abmessung BxTxH	E1	E2	E3	Euro
<i>Order no. / Référence</i>	<i>Size / Dimension</i>	*	*	*	
788.8705.200	425x375x300	14	10	6	325,00



Bestell-Nr.	Abmessung BxTxH	E1	E2	E3	Euro
<i>Order no. / Référence</i>	<i>Size / Dimension</i>	*	*	*	
788.8707.200	575x375x300	20	14	10	339,00



Bestell-Nr.	Abmessung BxTxH	E1	E2	E3	Euro
<i>Order no. / Référence</i>	<i>Size / Dimension</i>	*	*	*	
788.8705.400	425x375x525	28	20	12	471,00



Bestell-Nr.	Abmessung BxTxH	E1	E2	E3	Euro
<i>Order no. / Référence</i>	<i>Size / Dimension</i>	*	*	*	
788.8707.400	575x375x525	40	28	20	497,00

**\*Anzahl der möglichen Einsätze, für die Größen E1, E2, E3**

*\* Quantity of possible inserts, for sizes E1, E2, E3*

*\* Nombre des inserts possibles, pour les tailles E1, E2, E3*

**Внимание! Данный прайс-лист для европейского рынка.**

Цены в РФ значительно отличаются от цен, указанных в данном документе!

Для получения актуальной стоимости, обращайтесь по контактам, указанным ниже.

kemmler@kemmler.su  
 www.kemmler.su

**CNC Werkzeugwagen**  
Trolley for CNC toolholders  
Chariot pour porte-outils CNC

**System 2**



**CNC Werkzeugwagen (leer) für max. 8 CNC Träger**  
**Maximale Tragkraft 400kg**  
**Ohne Werkzeuge und Einsätze**  
*Trolley (empty) for max. 8 carriers*  
*Maximum lifting force 400kg.*  
*Without toolholders and inserts.*  
*Chariot (vide) pour 8 supports*  
*maximum force portante max. 400 kg*  
*sans outils et inserts*

Bestell-Nr. Order no. / Référence	Abmessung BxTxH Size / Dimension	Euro
799.02.88.0*	630x900x860	1045,00

**CNC Werkzeugaufnahmeträger**  
Tool carrier for CNC toolholders  
Support pour porte-outils CNC

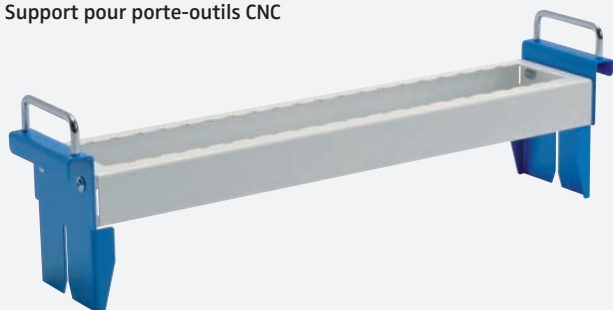

Bestell-Nr. Order no. / Référence	Abmessung BxTxH Size / Dimension	E1	E2	E3	Euro
799.28.707.100	620x120x180	10	7	5	144,00



**\*Anzahl der möglichen Einsätze, für die Größen E1, E2, E3**

\* Quantity of possible inserts, for sizes E1, E2, E3

\* Nombre des inserts possibles, pour les tailles E1, E2, E3

\*zzgl. Speditionskosten

\*carrying costs in addition

\*majoré de frais de transport

**Внимание! Данный прайс-лист для европейского рынка.**

Цены в РФ значительно отличаются от цен, указанных в данном документе!

Для получения актуальной стоимости, обращайтесь по контактам, указанным ниже.

**KEMMLER**

**137**



## Präzisionsschraubstöcke

Precision vices

Etaux de précision

### Maschinen-Schraubstöcke Mechanisch mit Spannkraftverstärker

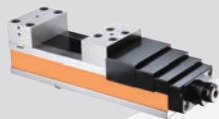

Machine vices  
with mechanical booster  
Étaux à haute pression avec répéteur  
de la tension du ressort mécanique

Bestell-Nr. Order no. / Référence	Ausführung Version / Type	Euro
KS14010	AVK-160G/HV	2.310,00*

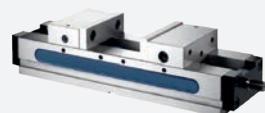

Zentrischspanner, mechanisch  
Self-centering machine vice  
Étau autocentrant

Bestell-Nr. Order no. / Référence	Ausführung Version / Type	Euro
KS19010	HLD-60G/HV	1.995,00*

### Maschinen-Schraubstöcke Mechanisch mit Spannkraftverstärker

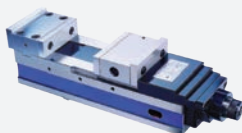

Machine vices  
with mechanical booster  
Étaux à haute pression avec répéteur  
de la tension du ressort mécanique

Bestell-Nr. Order no. / Référence	Ausführung Version / Type	Euro
KS01010	ALQ-160G/HV	1.995,00*
KS01020	ALQ-200G/HV	2.289,00*

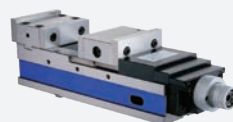

### Maschinen-Schraubstöcke Mechanisch mit Spannkraftverstärker

Machine vices  
with mechanical booster  
Étaux à haute pression avec répéteur  
de la tension du ressort mécanique

Bestell-Nr. Order no. / Référence	Ausführung Version / Type	Euro
KS02010	AVQ-100G/HV	1.334,00
KS02020	AVQ-125G/HV	1.470,00*
KS02030	AVQ-160G/HV	1.859,00*
KS02040	AVQ-200G/HV	2.153,00*

### Maschinen-Schraubstöcke Mechanisch mit Spannkraftverstärker



Machine vices  
with mechanical booster  
Étaux à haute pression avec répéteur  
de la tension du ressort mécanique

Bestell-Nr. Order no. / Référence	Ausführung Version / Type	Euro
KS15010	AVM-160G/HV	1.796,00*
KS15020	AVM-200G/HV	2.111,00*



### Maschinen-Schraubstöcke Mechanisch

Machine vices mechanical  
Étaux à haute pression  
mécanique

Bestell-Nr. Order no. / Référence	Ausführung Version / Type	Euro
KS16010	AVC-160G/HV	1.638,00*
KS16020	AVC-200G/HV	1.964,00*



### Maschinen-Schraubstöcke Mechanisch

Machine vices mechanical  
Étaux à haute pression  
mécanique

Bestell-Nr. Order no. / Référence	Ausführung Version / Type	Euro
KS05010	AVL-100G/HV	914,00
KS05020	AVL-125G/HV	1040,00*
KS05030	AVL-160G/HV	1.386,00*
KS05040	AVL-200G/HV	2.247,00*

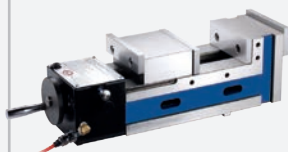

### Maschinen-Schraubstöcke Pneumatik-Hydraulisch

Pneumatic machine vices  
hydraulic  
Étaux pneumatiques  
hydraulique

Bestell-Nr. Order no. / Référence	Ausführung Version / Type	Euro
KS18150	AMP-150G/HV	2.489,00*
KS18160	AMP-160G/HV	2.793,00*
KS18165	AMP-165G/HV	2.961,00*
KS18180	AMP-180G/HV	3.119,00*
KS18200	AMP-200G/HV	3.287,00*
KS18300	AMP-300G/HV	3.623,00*

\*zzgl. Speditionskosten  
\*carrying costs in addition  
\*majoré de frais de transport

Внимание! Данный прайс-лист для европейского рынка.

Цены в РФ значительно отличаются от цен, указанных в данном документе!

Для получения актуальной стоимости, обращайтесь по контактам, указанным ниже.

kemmler@kemmler.su  
www.kemmler.su

## Präzisionsschraubstöcke

Precision vices

Étaux de précision

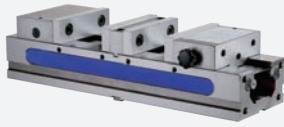

### Doppelspannstöcke mechanisch

Twin vices mechanical  
Étaux à double serrage  
mécanique

Bestell-Nr. Order no. / Référence	Ausführung Version / Type	Euro
KS09010	TLD-40G/HV	1.386,00
KS09020	TLD-60G/HV	1.533,00*

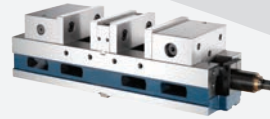

### Doppelspannstöcke mechanisch

Twin vices mechanical  
Étaux à double serrage  
mécanique

Bestell-Nr. Order no. / Référence	Ausführung Version / Type	Euro
KS10010	ALD-60G/HV	1.638,00*

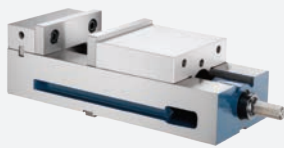

### Maschinen-Schraubstöcke mechanisch

Machine vices mechanical  
Étaux à haute pression  
mécanique

Bestell-Nr. Order no. / Référence	Ausführung Version / Type	Euro
KS12010	AMC-40G/HV	588,00
KS12020	AMC-60G/HV	683,00*

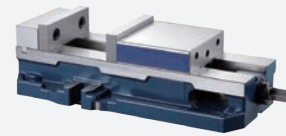

### Maschinen-Schraubstöcke mechanisch

Machine vices mechanical  
Étaux à haute pression  
mécanique

Bestell-Nr. Order no. / Référence	Ausführung Version / Type	Euro
KS11010	ATD-460	410,00
KS11020	ATD-570	462,00

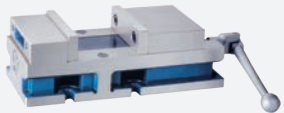

### Maschinen-Schraubstöcke mechanisch

Machine vices mechanical  
Étaux à haute pression  
mécanique

Bestell-Nr. Order no. / Référence	Ausführung Version / Type	Euro
KS13010	MG-60G/HV	882,00*

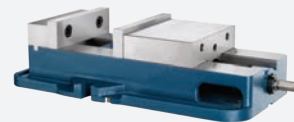

### Maschinen-Schraubstöcke mechanisch

Machine vices mechanical  
Étaux à haute pression  
mécanique

Bestell-Nr. Order no. / Référence	Ausführung Version / Type	Euro
KS11030	ATW-675	515,00*
KS11040	ATW-689	588,00*
KS11050	ATW-810	1.145,00*

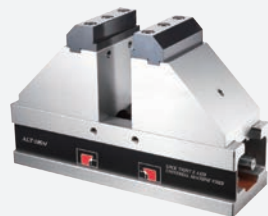

### 5-Achs Maschinen-Schraubstöcke

5-Axis-  
Machine vices  
Étaux à 5-axes

Bestell-Nr. Order no. / Référence	Ausführung Version / Type	Euro
KS20100	ALT-100M	3.210,00*
KS20101	ALT-100L	4.170,00*

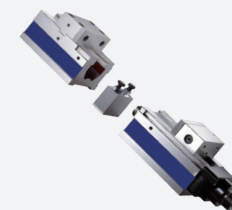

### Mehrfachspannsystem 3-teilig

Multiple Clamping System  
3-parts  
Système multiple de serrage  
3-pièces

Bestell-Nr. Order no. / Référence	Ausführung Version / Type	Euro
KS22020	AOM-200/HV	2.100,00*

\*zzgl. Speditionskosten

\*carrying costs in addition

\*majoré de frais de transport

Внимание! Данный прайс-лист для европейского рынка.  
Цены в РФ значительно отличаются от цен, указанных в данном документе!  
Для получения актуальной стоимости, обращайтесь по контактам, указанным ниже.







## Презицијонска шраубстојке

Precision vices  
Etau de précision

### Машина-шраубстојке Механички са спонкративерстајкер

Machine vices  
with mechanical booster  
Étau à haute pression  
avec répéteur de la tension  
du ressort mécanique



Bestell-Nr. Order no. / Référence	Ausführung Version / Type	Euro
KS06010	MP-50A	882,00*
KS06020	MP-60A	934,00*
KS06030	MP-80A	1.838,00*

### Воркстуканшлаг АТВ

Workpiece stop ATW  
Dispositif de butée ATW



Bestell-Nr. Order no. / Référence	Ausführung Version / Type	Euro
Z.KS.ATW40ST	4" ATW-40/ATD-460	105,00
Z.KS.ATW50ST	5" ATW-50/ATD-570	120,00
Z.KS.ATW60ST	6" ATW-675/ATW-689	150,00
Z.KS.ATW80ST	8" ATW-810	195,00

### Дрехплате

Swivel base  
Plateau tournant

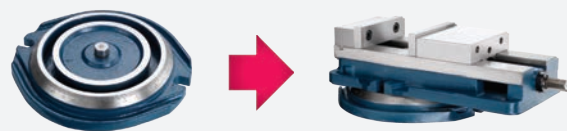

Bestell-Nr. Order no. / Référence	Ausführung Version / Type	Euro
Z.KS.HP402A	HP-40	126,00
Z.KS.HP502A	HP-50 / MP-50	135,00
Z.KS.HP602A	HP-60 / MP-60	147,00
Z.KS.HP802A	HP-80 / MP-80	294,00
Z.KS.AT413A	ATW-40 / ATD-460	126,00
Z.KS.AT513A	ATW-50 / ATD-570	135,00
Z.KS.AT613A	ATW-675 / ATW689	147,00
Z.KS.AT813A	ATW-810	294,00



### Машина-шраубстојке Хидраулички

Machine vices hydraulic  
Étau à haute pression  
hydraulique

Bestell-Nr. Order no. / Référence	Ausführung Version / Type	Euro
KS07010	HP-40A	830,00
KS07020	HP-50A	882,00*
KS07030	HP-60A	935,00*
KS07040	HP-80A	1.827,00*



### Машина-шраубстојке Хидраулички

Machine vices hydraulic  
Étau à haute pression  
hydraulique

Bestell-Nr. Order no. / Référence	Ausführung Version / Type	Euro
KS08010	HPT-40	1.502,00
KS08020	HPT-60	1.943,00*



### Бормашина- шраубстојке, механички

Vices for drilling machines,  
mechanical  
Étau pour foreuses,  
mécanique

Bestell-Nr. Order no. / Référence	Ausführung Version / Type	Euro
KS4080	MWM-80	50,00
KS4100	MWM-100	80,00
KS4150	MWM-150	120,00
KS4200	MWM-200	190,00



### Воркстуканшлаг, универсал

Workpiece stop, universal  
Dispositif de butée, universel

Bestell-Nr. Order no. / Référence	Ausführung Version / Type	Euro
Z.KS.ATS160BH	ATS-160BH/T-16mm	216,00

\*zzgl. Speditionskosten  
\*carrying costs in addition  
\*majoré de frais de transport

Внимание! Данный прайс-лист для европейского рынка.

Цены в РФ значительно отличаются от цен, указанных в данном документе!

Для получения актуальной стоимости, обращайтесь по контактам, указанным ниже.

kemmler@kemmler.su  
www.kemmler.su



## Präzisionsschraubstöcke

Precision vices  
Etaux de précision

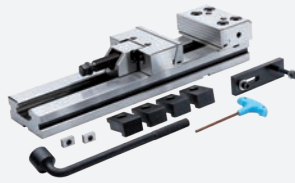

**Maschinen-Schraubstöcke**  
mechanisch  
Machine vices mechanical  
Étaux à haute pression  
mécanique

Bestell-Nr. Order no. / Référence	Ausführung Version / Type	Euro
KS30125	ATI-125	687,00*
KS30150	ATI-150	1080,00*
KS30175	ATI-175	1100,00*
KS30200	ATI-200	1850,00*

### Drehplatte

Swivel base  
Plateau tournant

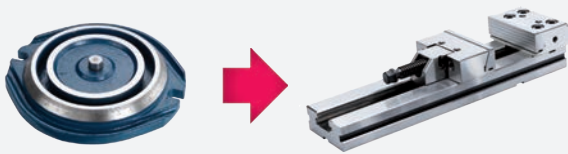

Bestell-Nr. Order no. / Référence	Ausführung Version / Type	Euro
Z.KS.30125	ATI-125	315,00
Z.KS.30150	ATI-150	360,00
Z.KS.30175	ATI-175	405,00
Z.KS.30200	ATI-200	450,00



**Ersatzbacken**  
Jaws  
Mors d'échange

Bestell-Nr. Order no. / Référence	Ausführung Version / Type	Euro
Z.KS.ALT4401	ALT-100M/ALT-100L	210,00

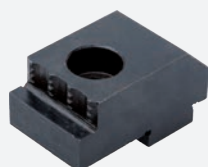

**Ersatzbacken**  
Jaws  
Mors d'échange

Bestell-Nr. Order no. / Référence	Ausführung Version / Type	Euro
Z.KS.ALT4403	ALT-100M/ALT-100L	285,00

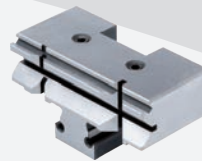

**Prismenbacken**  
Prismatic jaws  
Mors prismatiques

Bestell-Nr. Order no. / Référence	Ausführung Version / Type	Euro
Z.KS.PR.30125	ATI-125	140,00
Z.KS.PR.30150	ATI-150	180,00
Z.KS.PR.30175	ATI-175	210,00
Z.KS.PR.30200	ATI-200	290,00

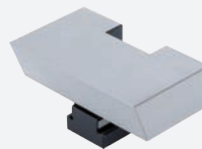

**Niederzugbacken**  
Hold down jaws  
Mors d'emboutissage

Bestell-Nr. Order no. / Référence	Ausführung Version / Type	Euro
Z.KS.NZ.30125	ATI-125	140,00
Z.KS.NZ.30150	ATI-150	190,00
Z.KS.NZ.30175	ATI-175	240,00
Z.KS.NZ.30200	ATI-200	290,00



**Ersatzbacken**  
Jaws  
Mors d'échange

Bestell-Nr. Order no. / Référence	Ausführung Version / Type	Euro
Z.KS.ALT4402	ALT-100M/ALT-100L	300,00



**Ersatzbacken**  
Jaws  
Mors d'échange

Bestell-Nr. Order no. / Référence	Ausführung Version / Type	Euro
Z.KS.ALT4404	ALT-100M/ALT-100L	225,00

Внимание! Данный прайс-лист для европейского рынка.  
Цены в РФ значительно отличаются от цен, указанных в данном документе!  
Для получения актуальной стоимости, обращайтесь по контактам, указанным ниже.





## Präzisionsschraubstöße

Precision vices

Etaux de précision



### Prismenbacken

Prismatic jaws

Mors prismatiques

Bestell-Nr. Order no. / Référence	Ausführung Version / Type	Euro
Z.KS.PR.AT409R	ATW-40 / ATD-460	126,00
Z.KS.PR.AT509R	ATW-50 / ATD-570	133,00
Z.KS.PR.AT609R	ATW675/689/MG60/ AMC60/TLD60	152,00
Z.KS.PR.AT809R	ATW-810	221,00
Z.KS.PR.AVQ4407	AVQ / AVL-100	133,00
Z.KS.PR.AVQ5407	AVQ / AVL-125	142,00
Z.KS.PR.AVQ6407	AVQ / AVL-160	171,00
Z.KS.PR.AVQ8407	AVQ / AVL-200	205,00
Z.KS.PR.HP403R	HP-40	126,00
Z.KS.PR.HP503R	HP / MP-50	136,00
Z.KS.PR.HP603R	HP / MP-60	167,00
Z.KS.PR.HP803R	HP / MP-80	227,00
Z.KS.PR.AVC6407	AVC / AVM-160	174,00
Z.KS.PR.AVC8407	AVC / AVM-200	227,00
Z.KS.PR.TLD4404	TLD-40	234,00
Z.KS.PR.ALD6404	ALD-60	366,00



### Stufenbacken (Paar)

Step jaws (Pair)

Mors étagés (Paire)

Bestell-Nr. Order no. / Référence	Ausführung Version / Type	Euro
Z.KS.ST.AT409L	ATW-40 / ATD-460	98,00
Z.KS.ST.AT509L	ATW-50 / ATD-570	104,00
Z.KS.ST.AT609L	ATW-675/689/MG- 60/AMC60/TLD60/ AMC60/TLD60	114,00
Z.KS.ST.AT809L	ATW-810	207,00
Z.KS.ST.AVQ4404	AVQ / AVL-100	111,00
Z.KS.ST.AVQ5404	AVQ / AVL-125	126,00
Z.KS.ST.AVQ6404	AVQ / AVL-160	145,00
Z.KS.ST.AVQ8404	AVQ / AVL-200	259,00
Z.KS.ST.AVC6404	AVC / AVM-160	126,00
Z.KS.ST.AVC8404	AVC / AVM-200	268,00
Z.KS.ST.AMC409L	AMC-40	101,00
Z.KS.ST.TLD4402	TLD-40	208,00
Z.KS.ST.ALD6403	ALD-60	174,00

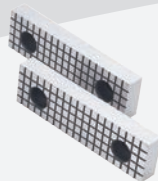

### Geriffelte Backen (Paar)

Serrated jaws (Pair)

Mors à rainures (Paire)

Bestell-Nr. Order no. / Référence	Ausführung Version / Type	Euro
Z.KS.GR.AT409T	ATW-40 / ATD-460	186,00
Z.KS.GR.AT509T	ATW-50 / ATD-570	205,00
Z.KS.GR.AT609T	ATW675/689/ MG60/AMC60/TLD60	223,00
Z.KS.GR.AT809T	ATW-810	321,00
Z.KS.GR.AVQ4405	AVQ / AVL-100	205,00
Z.KS.GR.AVQ5405	AVQ / AVL-125	230,00
Z.KS.GR.AVQ6405	AVQ / AVL-160	268,00
Z.KS.GR.AVQ8405	AVQ / AVL-200	315,00
Z.KS.GR.HP403T	HP-40	174,00
Z.KS.GR.HP503T	HP / MP-50	199,00
Z.KS.GR.HP603T	HP / MP-60	262,00
Z.KS.GR.HP803T	HP / MP-80	378,00
Z.KS.GR.AVC6405	AVC / AVM-160	249,00
Z.KS.GR.AVC8405	AVC / AVM-200	331,00
Z.KS.GR.TLD4403	TLD-40	413,00
Z.KS.GR.AMC409T	ALD-60	183,00



### Niederzugbacken (Paar)

Hold down jaws (Pair)

Mors d'emboutissage (Paire)

Bestell-Nr. Order no. / Référence	Ausführung Version / Type	Euro
Z.KS.NZ.HP403DA	HP-40	237,00
Z.KS.NZ.HP503DA	HP / MP-50	252,00
Z.KS.NZ.HP603DA	HP / MP-60	278,00
Z.KS.NZ.HP803DA	HP / MP-80	372,00

9

Внимание! Данный прайс-лист для европейского рынка.

Цены в РФ значительно отличаются от цен, указанных в данном документе!

Для получения актуальной стоимости, обращайтесь по контактам, указанным ниже.

## Präzisionserschraubstöße

Precision vices

Etaux de précision



### Ersatzbacken (Paar)

Spare jaws (Pair)  
Mors d'échange (Paire)

Bestell-Nr. Order no. / Référence	Ausführung Version / Type	Euro
Z.KS.SA.AT409	ATW-40 / ATD-460	79,00
Z.KS.SA.AT509	ATW-50 / AMC-50 / ATD-570	95,00
Z.KS.SA.ATL609	ATW-675 / ATW-689 / MG-60 / AMC-60 / TLD-60	98,00
Z.KS.SA.ATL809	ATW-810	202,00
Z.KS.SA.AMC409	AMC-40	70,00
Z.KS.SA.AVQ4401	AVQ-100 / AVL-100	82,00
Z.KS.SA.AVQ5401	AVQ-125 / AVL-125	95,00
Z.KS.SA.AVQ6401	AVQ-160 / AVL-160 / ALQ-160	133,00
Z.KS.SA.AVQ8401	AVQ-160 / AVL-200 / ALQ-160	205,00
Z.KS.SA.HP403	HP-40	70,00
Z.KS.SA.HP503	HP-50 / MP-50	82,00
Z.KS.SA.HP603	HP-60 / MP-60	126,00
Z.KS.SA.HP803	HP-80 / MP-80	212,00
Z.KS.SA.AVC6401	AVC-160 / AVM-160	111,00
Z.KS.SA.AVC8401	AVC-200 / AVM-200	130,00
Z.KS.SA.TLD4401	TLD-40	133,00
Z.KS.ST.ALD6403	ALD-60	174,00

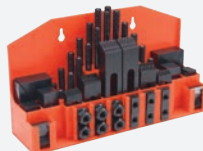

### Aufspannsätze

Clamping sets  
Jeux de serrage

Bestell-Nr. Order no. / Référence	Ausführung Version / Type	Euro
Z.KS.ACK08	M8x1,25 - 10mm T-Nut	149,00
Z.KS.ACK10	M10x1,5 - 12mm T-Nut	149,00
Z.KS.ACK12A	M12x1,75 - 14mm T-Nut	159,00
Z.KS.ACK12B	M12x1,75 - 16mm T-Nut	159,00
Z.KS.ACK12C	M12x1,75 - 18mm T-Nut	159,00

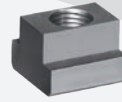

### T-Nuten (T-Nutensteine)

T-Nuts  
Tasseaux

Bestell-Nr. Order no. / Référence	Ausführung Version / Type	Euro
Z.KS.80010	M6x8	9,00
Z.KS.80028	M8x10	9,00
Z.KS.80036	M10x12	16,00
Z.KS.800366	M10x16	16,00
Z.KS.81265	M10x18	16,00
Z.KS.80176	M14x18	16,00
Z.KS.80077	M18x20	28,00
Z.KS.80242	M18x22	28,00
Z.KS.80093	M22x24	30,00



### Scheiben DIN 6340

Plain washers DIN 6340  
Joints DIN 6340

Bestell-Nr. Order no. / Référence	Ausführung Version / Type	Euro
Z.KS.82818	M6	6,00
Z.KS.82826	M8	6,00
Z.KS.82834	M10	6,00
Z.KS.82859	M14	6,00
Z.KS.82875	M18	6,00
Z.KS.82891	M22	9,00

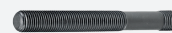

### Stiftschrauben DIN 6379

Studs DIN 6379  
Boulon fileté DIN 6379

Bestell-Nr. Order no. / Référence	Ausführung Version / Type	Euro
Z.KS.84780	M6x50	10,00
Z.KS.81257	M8x40	10,00
Z.KS.81299	M10x50	10,00
Z.KS.84830	M10x80	10,00
Z.KS.81372	M14x63	15,00
Z.KS.84954	M18x125	20,00
Z.KS.86561	M18x160	20,00
Z.KS.81539	M22x160	30,00



### Sechskantmuttern DIN 6330B

Fixture nuts DIN 6330B  
Écrou hexagonal DIN 6330B

Bestell-Nr. Order no. / Référence	Ausführung Version / Type	Euro
Z.KS.82362	M6	8,00
Z.KS.82370	M8	8,00
Z.KS.82354	M10	8,00
Z.KS.82321	M14	8,00
Z.KS.82420	M18	10,00
Z.KS.82339	M22	10,00

Внимание! Данный прайс-лист для европейского рынка.  
Цены в РФ значительно отличаются от цен, указанных в данном документе!  
Для получения актуальной стоимости, обращайтесь по контактам, указанным ниже.





## Präzisionsschraubstöcke

Precision vices

Etaux de précision



### Schleif- und Kontrollschraubstöcke mit Gewindespindel

Grinding and inspection vices with threaded spindle

Etaux de contrôle et de rectification à réglage à vis

Bestell-Nr. Order no. / Référence	Ausführung Version / Type	Euro
90.11.050	50	168,00
90.11.073	73	231,00
90.11.100	100	305,00

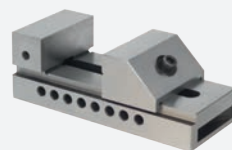

### Schleif- und Kontrollschraubstöcke mit Schnellverstellung

Grinding and inspection vices with quick adjustment

Etaux de contrôle et de rectification à réglage rapide

Bestell-Nr. Order no. / Référence	Ausführung Version / Type	Euro
90.12.050	50	116,00
90.12.073	73	147,00
90.12.100	100	305,00



### Universal-Schleif- und Kontrollschraubstöcke

Universal, grinding and inspection vices

Etaux de contrôle et de rectification universel

Bestell-Nr. Order no. / Référence	Ausführung Version / Type	Euro
90.17.080	195 x 110 x 137	945,00



### Parallel-Unterlagen-Sätze

Set of parallel supports

Jeu de supports parallèles

Bestell-Nr. Order no. / Référence	Ausführung Version / Type	Euro
91.12.150.1	14 x 2 - 150x10x14	200,00
91.12.150.2	14 x 2 - 150 x 8 x14	200,00
91.12.200.3	14 x 2 - 200x10x14	263,00
91.13.100.1	9 x 2 - 100x4x10	168,00



### Winkelprisma, einstellbar

Adjustable prism square

Équerre à prisme, ajustable

Bestell-Nr. Order no. / Référence	Ausführung Version / Type	Euro
GAP-25	75x25x36x25	165,00
GAP-30	102x30x49x30	189,00
GAP-46	102x46x49x30	219,00

9

Внимание! Данный прайс-лист для европейского рынка.

Цены в РФ значительно отличаются от цен, указанных в данном документе!

Для получения актуальной стоимости, обращайтесь по контактам, указанным ниже.

kemmler@kemmler.su  
www.kemmler.su



# Inhaltsverzeichnis

Index

Table de matières



146



146



146



146



146



146



147



147



147



147

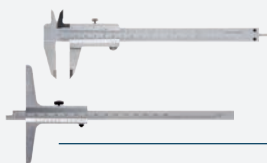

148



148



148

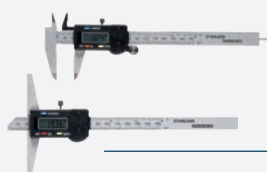

148



148



149

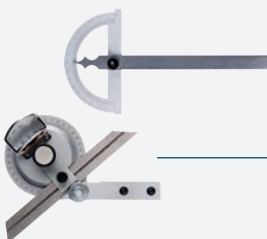

149

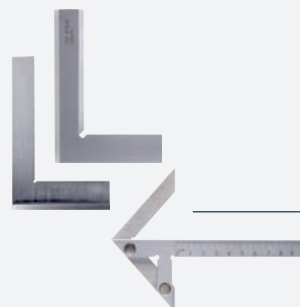

149

Внимание! Данный прайс-лист для европейского рынка.  
Цены в РФ значительно отличаются от цен, указанных в данном документе!  
Для получения актуальной стоимости, обращайтесь по контактам, указанным ниже.

kemmler@kemmler.su  
www.kemmler.su

**KEMMLER**

**145**





**Kantentaster mechanisch**  
Edge finders mechanical  
Palpeurs d'angle mécanique

Bestell-Nr. Order no. / Référence	Abmessung Size / Dimension	Euro
702.10	10 - 84 -10	17,00
702.10.4	10 - 94 -10/4	17,00



**Kantentaster elektronisch 2D**  
Edge finders electronic 2D  
Palpeurs d'angle électronique 2D

Bestell-Nr. Order no. / Référence	Abmessung Size / Dimension	Euro
702.16	16 - 100 -10	79,00
702.20	20 - 160 -10	84,00



**Kantentaster elektronisch 3D**  
Edge finders electronic 3D  
Palpeurs d'angle électronique 3D

Bestell-Nr. Order no. / Référence	Abmessung Size / Dimension	Euro
702.3.16	16 - 111 -10	157,00
702.3.20	20 - 106 -10	157,00



**Kantentaster elektronisch 3D**  
Edge finders electronic 3D  
Palpeurs d'angle électroniques 3D

Bestell-Nr. Order no. / Référence	Abmessung Size / Dimension	Euro
702.6.20	20 - 173 - 6	499,00



**Null-Einstellgeräte ohne Magnet**  
Z-Axis Zero-setters without magnet  
Dispositif de mise à zéro sans aimant

Bestell-Nr. Order no. / Référence	Abmessung Size / Dimension	Euro
702.5.48.1	65 - 50 - 48	147,00

Referenzhöhe / Height / Hauteur 50 mm



**Null-Einstellgeräte mit Magnet**  
Z-Axis Zero-setters with magnet  
Dispositif de mise à zéro avec aimant

Bestell-Nr. Order no. / Référence	Abmessung Size / Dimension	Euro
702.5.48.2	61 - 54 - 52	179,00

Referenzhöhe / Height / Hauteur 50 mm



**Null-Einstellgeräte elektronisch mit Magnet**  
Electronic Z-Axis Zero-setters with magnet  
Appareils de réglage du zéro électronique avec aimant

Bestell-Nr. Order no. / Référence	Abmessung Size / Dimension	Euro
702.4.19	56 - 50 - 14	118,00

Referenzhöhe / Height / Hauteur 50 mm



**Kantentaster mechanisch 3D**  
Edge finders mechanical 3D  
Palpeurs d'angle mécanique 3D

Bestell-Nr. Order no. / Référence	Abmessung Size / Dimension	Euro
702.7.20	20 - 4 - 162,50	625,00



Внимание! Данный прайс-лист для европейского рынка.

Цены в РФ значительно отличаются от цен, указанных в данном документе!

Для получения актуальной стоимости, обращайтесь по контактам, указанным ниже.

kemmler@kemmler.su  
www.kemmler.su

## Messtechnik

Measuring technique  
Métrologie



**Präzisions-Messuhren DIN 878**  
Prec. dial indicator DIN 878  
Comparateurs DIN 878

Bestell Nr. Order no. Référence	∅	Skalenwert Scala Gamme	Messbereich Range Gamme de mesure	Euro
65.00.00001	40	0,01	5	20,00
65.00.00002	58	0,01	10	18,00
65.00.00003	58	0,01	30	52,00
65.00.10001	58	0,001	1	38,00



**Digital-Messuhren**  
Digital dial gauge  
Comparateurs numériques

Bestell Nr. Order no. Référence	∅	Skalenwert Scala Gamme	Messbereich Range Gamme de mesure	Euro
65.10.00001	58	0,01	12,7	122,00
65.11.00001	58	0,001	12,7	244,00

mit Datenausgang RS 232  
with RS 232 data output  
avec sortie de données RS 232



**Fühlhebelmessgeräte DIN 2270**  
Universal test indicator DIN 2270  
Indicateurs à levier DIN 2270

Bestell Nr. Order no. Référence	∅	Skalenwert Scala Gamme	Messbereich Range Gamme de mesure	Euro
65.15.00001	32	0,01	0,8	53,00
65.15.00002	32	0,002	0,2	66,00



**Dreipunkt-Innen-Messschrauben-Satz - DIN 863**  
Three point internal micrometer set - DIN 863  
jeu de micromètres d'intérieur à 3 points - DIN 863

Bestell Nr. Order no. Référence	Skalenwert Scala Gamme	Messbereich Range Gamme de mesure	Euro
66.00.612	0,001	6 – 12	1.174,00
66.00.1220	0,005	12 – 20	636,00
66.00.2050	0,005	20 – 50	1.523,00
66.00.50100	0,005	50 – 100	2.006,00



**Bügelmessschrauben DIN 863**  
External micrometer DIN 863  
Micromètres extérieurs DIN 863

Bestell Nr. Order no. Référence	Skalenwert Scala Gamme	Messbereich Range Gamme de mesure	Euro
63.00.00025	0,01	0 – 25	26,00
63.00.00050	0,01	25 – 50	28,00
63.00.00075	0,01	50 – 75	29,00
63.00.00100	0,01	75 – 100	32,00
63.00.00125	0,01	100 – 125	35,00
63.00.00150	0,01	125 – 150	41,00
63.00.00175	0,01	150 – 175	56,00
63.00.00200	0,01	175 – 200	68,00
63.00.10100	0,01	0 – 100*	105,00

\* Satz mit 4 St.  
\* Set with 4 pcs.  
\* Jeux avec 4 pc.

**Digitale-Bügelmessschrauben spritzwasserfest DIN 863**  
Prec. digital micrometers water resistant DIN 863  
Micromètres extérieurs numériques, protégé contre les projections d'eau DIN 863



Bestell Nr. Order no. Référence	Skalenwert Scala Gamme	Messbereich Range Gamme de mesure	Euro
63.50.00025	0,001	0 – 25	109,00
63.50.00050	0,001	25 – 50	126,00
63.50.00075	0,001	50 – 75	141,00
63.50.00100	0,001	75 – 100	163,00
63.50.10100	0,001	0 – 100*	536,00

mit Datenausgang IP 54  
with IP 54 data output  
avec sortie de données IP 54

\* Satz mit 4 St.  
\* Set with 4 pcs.  
\* Jeux avec 4 pc.



**Digital-Dreipunkt-Innen-Messschrauben-Satz - IP 54**  
Digital three point internal micrometer set - IP 54  
jeu de micromètres d'intérieur à 3 points - IP 54

Bestell Nr. Order no. Référence	Skalenwert Scala Gamme	Messbereich Range Gamme de mesure	Euro
66.01.612	0,001	6 – 12	1.827,00
66.01.1220	0,001	12 – 20	1.187,00
66.01.2050	0,001	20 – 50	2.415,00
66.01.50100	0,001	50 – 100	2.919,00

Внимание! Данный прайс-лист для европейского рынка.  
Цены в РФ значительно отличаются от цен, указанных в данном документе!  
Для получения актуальной стоимости, обращайтесь по контактам, указанным ниже.





**Taschenmessschieber  
DIN 862**

Vernier calipers DIN 862  
Pieds à coulisse  
à vernier vissé DIN 862

Bestell-Nr. Order no. Référence	Skalenwert Scala Gamme	Messbereich Range Gamme de mesure	Euro
62.00.00150	0,05	0 – 150	21,00
62.00.00300	0,05	0 – 300	57,00



**Uhrenmessschieber  
DIN 862**

Dial vernier calipers DIN 862  
Pieds à coulisse à montre  
DIN 862

Bestell-Nr. Order no. Référence	Skalenwert Scala Gamme	Messbereich Range Gamme de mesure	Euro
62.00.10150	0,02	0 – 150	38,00
62.00.10300	0,01	0 – 300	84,00



**Tiefenmessschieber  
DIN 862**

Depth vernier calipers  
DIN 862  
Jauges de profondeur  
à lecture vernier DIN 862

Bestell-Nr. Order no. Référence	Skalenwert Scala Gamme	Messbereich Range Gamme de mesure	Euro
62.05.00150	0,05	0 – 150	32,00
62.05.00300	0,05	0 – 300	49,00



**Magnet-Messstativ  
mit flexiblem Gliedarm**

Flexible magnetic dial gauge stands  
Base magnétique, flexible

Bestell Nr. Order no. Référence	Abmessung Size Dimension	Euro
68.00.65020	360	34,00



**Magnet-Messstativ**

Magnetic measuring stands  
Bases magnétique

Bestell Nr. Order no. Référence	Abmessung Size Dimension	Euro
68.00.65010	230	18,00



**Werkstatt-Messschieber  
mit Messerspitzen und  
Feineinstellung DIN 862**

Workshop caliper with knife  
edge jaws and with fine  
adjustment DIN 862  
Pieds à coulisse d'atelier avec  
pointes de mesure et réglage  
fin DIN 862

Bestell-Nr. Order no. Référence	Skalenwert Scala Gamme	Messbereich Range Gamme de mesure	Euro
62.00.15300	0,05	0 – 300	56,00

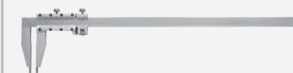

**Werkstatt-Messschieber mit  
Feineinstellung DIN 862**

Workshop caliper with fine  
adjustment DIN 862  
Pieds à coulisse d'atelier  
avec réglage fin DIN 862

Bestell-Nr. Order no. Référence	Skalenwert Scala Gamme	Messbereich Range Gamme de mesure	Euro
62.00.16500	0,02+0,01"	0 – 500	66,00
62.00.16100	0,02+0,01"	0 – 1000	207,00



**Digital-Messschieber**

Digital pocket vernier calipers  
Pieds à coulisse à lecture  
numérique

Bestell-Nr. Order no. Référence	Skalenwert Scala Gamme	Messbereich Range Gamme de mesure	Euro
62.00.05150	0,01	0 – 150	29,00
62.00.05300	0,01	0 – 300	82,00
62.01.05150 *	0,01	0 – 150	29,00
62.01.05300 *	0,01	0 – 300	83,00

\* mit Datenausgang RS 232 C

\* with RS 232 C data output

\* avec sortie de données RS 232 C



**Digital-Tiefenmessschieber**

Digital depth vernier calipers  
Jauges de profondeur à lecture  
numérique

Bestell-Nr. Order no. Référence	Skalenwert Scala Gamme	Messbereich Range Gamme de mesure	Euro
62.05.05150	0,01	0 – 150	39,00
62.05.05300	0,01	0 – 300	73,00
62.06.05150 *	0,01	0 – 150	45,00
62.06.05300 *	0,01	0 – 300	78,00

\* mit Datenausgang RS 232 C

\* with RS 232 C data output

\* avec sortie de données RS 232 C



Внимание! Данный прайс-лист для европейского рынка.

Цены в РФ значительно отличаются от цен, указанных в данном документе!

Для получения актуальной стоимости, обращайтесь по контактам, указанным ниже.

## Messtechnik

Measuring technique

Métrologie



### Höhenmess- und Anreissgeräte

*Vernier Height Gauges*

Trusquins de haute précision

Bestell-Nr. <i>Order no. Référence</i>	Skalenwert <i>Scala Gamme</i>	Messbereich <i>Range Gamme de mesure</i>	Euro
62.20.00300	0,02	0 – 300	78,00
62.20.00600	0,02	0 – 600	135,00



### Digital-Höhenmess- und Anreissgeräte

*Digital-height- and marking-gauges*

Trusquins de haute précision à lecteur numérique

Bestell-Nr. <i>Order no. Référence</i>	Skalenwert <i>Scala Gamme</i>	Messbereich <i>Range Gamme de mesure</i>	Euro
62.20.05300	0,01	0 – 300	193,00
62.21.05300 *	0,01	0 – 300	230,00

\* mit Datenausgang RS 232

\* with RS 232 data output

\* avec sortie de données RS 232



### Präzisions-Flachwinkel, DIN 875

*Prec. flat square, DIN 875*

Equerres de précision, DIN 875

Bestell-Nr. <i>Order no. / Référence</i>	Abmessung <i>Size / Dimension</i>	Euro
61.00.00100	100 × 70	16,00
61.00.00200	200 × 130	35,00

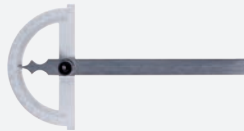

### Präzisions-Winkelmesser mit offenem Gradbogen

*Prec. protractors*

*with open graduated arc*

Rapporteurs d'angle

avec secteur gradué ajouré

Bestell-Nr. <i>Order no. / Référence</i>	Abmessung <i>Size / Dimension</i>	Euro
61.25.10080	80 × 120	24,00
61.25.10150	150 × 200	31,00



### Präzisions-Flachwinkel mit Anschlag, DIN 875

*Prec. flat square with back, DIN 875*

Equerres avec butée, DIN 875

Bestell-Nr. <i>Order no. Référence</i>	Abmessung <i>Size Dimension</i>	Euro
61.05.00100	100 × 70	21,00
61.05.00200	200 × 130	45,00

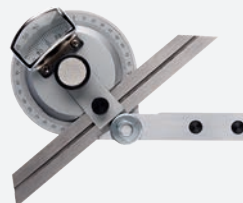

### Universal-Winkelmesser mit Feineinstellung, rostfrei

*Universal bevel protractors*

*with fine adjustment, stainless*

Rapporteurs d'angle

avec réglage fin, inox

Bestell-Nr. <i>Order no. Référence</i>	Schiene Länge <i>Length of rail Longeur de la barre</i>	Euro
61.25.00150	150	54,00
61.25.00300	300	58,00



### Präzisions-Haarwinkel, DIN 875

*Prec. bevelled edge, DIN 875*

Equerres biseautées, DIN 875

Bestell-Nr. <i>Order no. Référence</i>	Abmessung <i>Size Dimension</i>	Euro
61.10.00100	100 × 70	21,00
61.10.00200	200 × 130	38,00



### Zentrierwinkel, rostfrei

*Precision center squares,*

*stainless*

Equerres à centrer, inox

Bestell-Nr. <i>Order no. Référence</i>	Schenkel Länge <i>Length of arm Longeur du côté</i>	Euro
61.20.00100	100 × 70 max. Ø 90	28,00
61.20.00150	200 × 150 max. Ø 190	37,00

Внимание! Данный прайс-лист для европейского рынка.

Цены в РФ значительно отличаются от цен, указанных в данном документе!

Для получения актуальной стоимости, обращайтесь по контактам, указанным ниже.

**KEMMLER**







## Laserbeschriftung

der Werkzeuge

Laser engraving

of toolholders

Marquage laser

de porte-outils



### Laserbeschriftung von Werkzeugaufnahmen:

Durch unsere Laserbeschriftungsanlagen können wir Ihnen individuelle, kostengünstige Laserbeschriftung der Werkzeuge anbieten. Die dauerhafte Beschriftung kann mit Ihrem Firmennamen, Firmenlogo oder mit sonstigen Sonderzeichen erfolgen.

### Laser engraving of toolholders:

With our newly acquired laser engravers we can immediately offer you individual and cost-effective engraving of tools. The permanent engraving can include your company's name, logo or any other special description.

### Marquage laser de porte-outils:

A l'aide de notre dispositif de marquage laser nous sommes en mesure de labelliser vos porte-outils avec votre nom, logo ou autres données.

Внимание! Данный прайс-лист для европейского рынка.

Цены в РФ значительно отличаются от цен, указанных в данном документе!

Для получения актуальной стоимости, обращайтесь по контактам, указанным ниже.