



Präzisionsschraubstöcke mechanisch

Precision vices mechanical

Étaux de précision mécanique

Ausführung:

- Horizontal, vertikal oder seitlich aufspannbar
- Stahlkörper allseitig geschliffen und gehärtet
- Eingebauter Niederzug
- Betthöhe H: $\leq 0,01$ mm

Construction:

- Clamping positions: horizontal, vertical and lateral
- The steel body is hardened and grinded all-round
- Integrated pull-down mechanism
- Bed height H: $\leq 0,01$ mm

Type:

- Positions de serrage: horizontale, verticale ou latérale
- Corps en acier trempé et rectifié sur toutes les faces
- Répression basse incorporée
- Hauteur du socle H: $\leq 0,01$ mm

Lieferumfang:

- Bedienungsanleitung
- Incl. Spannschlüssel
- Messprotokoll

Delivery:

- Instructions for use
- Wrench
- Test certificate

Livraison avec:

- Mode d'emploi
- Clé de serrage
- Protocole de mesure

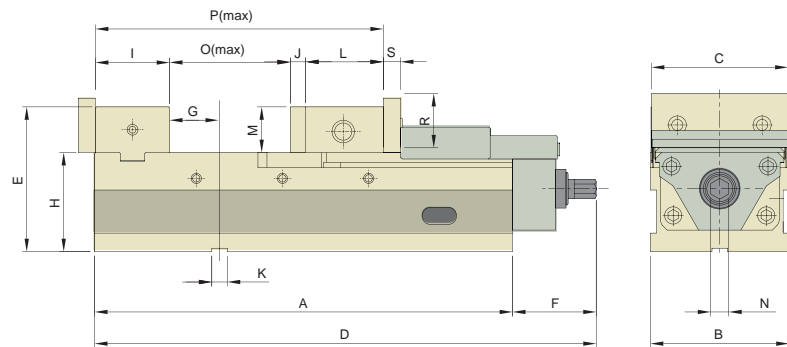
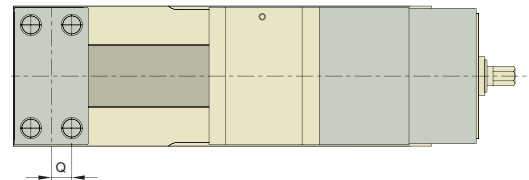

Bestell-Nr. Order no. Référence	Ausführung Version Type	A	B	C	D	E	F	G	H	I	J	K	L	M	N	O	P	Q	R	S	kg
KS05010	AVL-100G/HV	324	104	102,0	437	130	104	41	85	73	15	18	86,5	45	19	140	314,5	20,0	55	17	27
KS05020	AVL-125G/HV	390	127	125,0	480	153	105	66	100	78	15	18	87,5	53	19	201	381,5	22,5	63	20	43
KS05030	AVL-160G/HV	485	161	159,5	625	225	120	76	115	86	18	18	80,0	53	21	295	479,0	25,0	63	20	71
KS05040	AVL-200G/HV	535	202	199,5	660	260	128	93	120	101	18	18	95,0	58	19	320	534,0	31,0	73	20	98