

## Hydro-Dehnspannfutter

Hydraulic expansion chucks

Mandrins expansibles hydrauliques

JIS B 6339 AD/B



### Verwendung:

Zur Aufnahme von Werkzeugen mit Zylinderschaft nach DIN 1835 Form A+B+E und DIN 6535 Form HA+HB+HE (größer Ø 20 mm nur mit Reduzierung).

### Application:

For mounting straight-shank tools acc. DIN 1835 form A+B+E and DIN 6535 form HA+HB+HE (larger than dia. 20 mm only with reduction sleeve).

### Application:

Pour le serrage d'outils avec queue cylindrique suivant DIN 1835 forme A+B+E et DIN 6535 forme HA+HB+HE (à partir de dia. 20 mm seulement avec réduction).

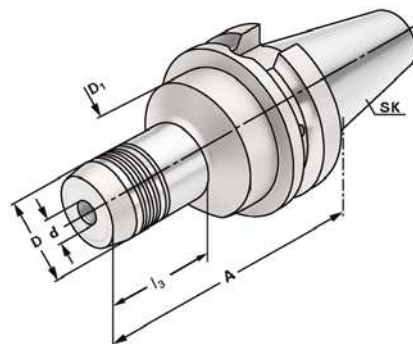

G 6,3 15.000 min<sup>-1</sup>

≤ 0,003

INFO → 10.03

2

Bestell-Nr. Order no. Référence	SK	d	A	D	D <sub>1</sub>	l <sub>1</sub>	l <sub>2</sub>	l <sub>3</sub>
406.H06.2	BT 40	6	200	26	50	152	10	152
406.H08.2	BT 40	8	200	28	50	153	10	153
406.H10.2	BT 40	10	200	30	50	154	10	154
406.H12.2	BT 40	12	200	32	50	155	10	155
406.H14.2	BT 40	14	200	34	50	155	10	155
406.H16.2	BT 40	16	200	38	50	156	10	156
406.H18.2	BT 40	18	200	40	50	157	10	157
406.H20.2	BT 40	20	200	42	50	158	10	158
406.H25.2	BT 40	25	200	50	50	173	10	173
406.H32.2	BT 40	32	200	60	50	173	10	173
506.H06	BT 50	6	110	26	80	37	10	43
506.H08	BT 50	8	110	28	80	37	10	43,5
506.H10	BT 50	10	110	30	80	42	10	44
506.H12	BT 50	12	110	32	80	47	10	42
506.H14	BT 50	14	110	34	80	47	10	42
506.H16	BT 50	16	110	38	80	52	10	45
506.H18	BT 50	18	110	40	80	52	10	45
506.H20	BT 50	20	110	42	80	52	10	47,5
506.H25	BT 50	25	110	50	80	58	10	47,5
506.H32	BT 50	32	110	60	80	62	10	47,5

Lieferumfang: Mit Spannschlüssel

Delivery: With wrench

Livraison: Avec clé de serrage

l<sub>1</sub> = max. Einstecktiefe

l<sub>1</sub> = max. clamping depth

l<sub>1</sub> = max. profondeur d'insertion

l<sub>2</sub> = max. Verstellweg

l<sub>2</sub> = max. length adjustment range

l<sub>2</sub> = max. course de réglage

