

Schrumpffutter zum Spannen von HM und HSS Werkzeugschäften

DIN 69871 AD/B



Shrink chucks for mounting of solid carbide and HSS-tool shanks

Mandrins de frettage pour le serrage de queues d'outils carbures de type HM et HSS



Verwendung:
Zur Aufnahme von Werkzeugen mit Zylinderschaft.

Application:
For mounting straight-shank tools.

Application:
Pour le serrage d'outils avec queue cylindrique.

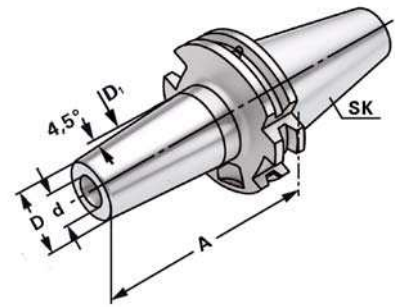

G 6,3 15.000 min⁻¹

≤ 0,003

Bestell-Nr. Order no. Référence	SK	d	A	D	D ₁	l ₁	l ₂
403.70.03	SK 40	3	80	11	15	10	–
403.70.04	SK 40	4	80	14	22	20	5
403.70.05	SK 40	5	80	16	22	20	5
403.70.06	SK 40	6	80	21	27	36	10
403.70.08	SK 40	8	80	21	27	36	10
403.70.10	SK 40	10	80	24	32	41	10
403.70.12	SK 40	12	80	24	32	47	10
403.70.14	SK 40	14	80	27	34	47	10
403.70.16	SK 40	16	80	27	34	50	10
403.70.18	SK 40	18	80	33	42	50	10
403.70.20	SK 40	20	80	33	42	52	10
403.70.25	SK 40	25	100	44	53	58	10
403.70.32	SK 40	32	100	44	53	62	10
403.70.03.1	SK 40	3	120	11	15	10	–
403.70.04.1	SK 40	4	120	14	22	20	5
403.70.05.1	SK 40	5	120	16	22	20	5
403.70.06.1	SK 40	6	120	21	27	36	10
403.70.08.1	SK 40	8	120	21	27	36	10
403.70.10.1	SK 40	10	120	24	32	41	10
403.70.12.1	SK 40	12	120	24	32	47	10
403.70.14.1	SK 40	14	120	27	34	47	10
403.70.16.1	SK 40	16	120	27	34	50	10
403.70.18.1	SK 40	18	120	33	42	50	10
403.70.20.1	SK 40	20	120	33	42	52	10
403.70.25.1	SK 40	25	120	44	53	58	10
403.70.32.1	SK 40	32	120	44	53	62	10

Für Ø 3, 4 und 5 mm nur Hartmetallschäfte verwenden!

For Ø 3, 4 and 5 mm only solid carbide tool shanks must be used!

Pour Ø 3, 4 et 5 mm il faut seulement utiliser de queues d'outils carbures de type HM!

Hinweis: Aufnahmen für Induktiv-, Kontakt- und Heißluftschumpfgeräte geeignet.
Schafttoleranz bei Ø 3, 4 und 5 mm = h₄, bei Ø 6–Ø 32 mm = h₆

Note: Toolholders suitable for induction-, contact- and hot air shrink units.
Ø 3, 4, 5 with h₄-tolerance and Ø 6–Ø 32 with h₆-tolerance

Observation: Porte-outils convenables pour machines à fretter par induction-,
par contact-, ou par air chaud.
Ø 3, 4, 5 avec h₄-tolerance et Ø 6–Ø 32 avec h₆-tolerance

l₁ = max. Einstecktiefe

l₁ = max. clamping depth

l₁ = max. profondeur d'insertion

l₂ = max. Verstellweg

l₂ = max. length adjustment range

l₂ = max. course de réglage

