



Hydro-Dehnspannfutter

Hydraulic expansion chucks

Mandrins expansibles hydrauliques

DIN 69871 AD/B

1



Verwendung:

Zur Aufnahme von Werkzeugen mit Zylinderschaft nach DIN 1835 Form A+B+E und DIN 6535 Form HA+HB+HE (größer Ø 20 mm nur mit Reduzierung).

Application:

For mounting straight-shank tools acc. DIN 1835 form A+B+E and DIN 6535 form HA+HB+HE (larger than dia. 20 mm only with reduction sleeve).

Application:

Pour le serrage d'outils avec queue cylindrique suivant DIN 1835 forme A+B+E et DIN 6535 forme HA+HB+HE (à partir de dia. 20 mm seulement avec réduction).

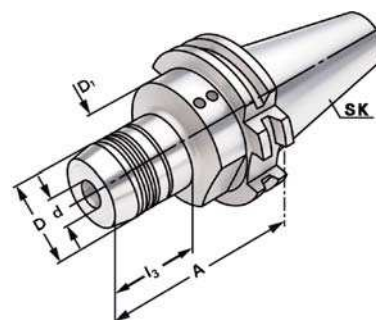

G 6,3 15.000 min⁻¹

≤ 0,003

INFO → 10.03

Bestell-Nr. Order no. Référence	SK	d	A	D	D ₁	l ₁	l ₂	l ₃
303.H06	SK 30	6	60	26	45	37	10	25
303.H08	SK 30	8	64	28	45	37	10	29
303.H10	SK 30	10	64	30	45	42	10	35
303.H12	SK 30	12	72	32	45	47	10	43
303.H14	SK 30	14	72	34	45	47	10	42
303.H16	SK 30	16	72	38	45	52	10	43
303.H18	SK 30	18	72	40	45	52	10	43
303.H20	SK 30	20	90	42	42	52	10	71
403.H06	SK 40	6	68	26	50	37	10	33
403.H08	SK 40	8	68	28	50	37	10	33
403.H10	SK 40	10	72	30	50	42	10	37
403.H12	SK 40	12	77	32	50	47	10	42
403.H14	SK 40	14	77	34	50	47	10	42
403.H16	SK 40	16	80	38	50	52	10	43
403.H18	SK 40	18	80	40	50	52	10	43
403.H20	SK 40	20	82	42	50	52	10	47
403.H25	SK 40	25	117	50	63	58	10	51
403.H32	SK 40	32	117	60	63	62	10	56
403.H06.1	SK 40	6	110	26	50	37	10	33
403.H08.1	SK 40	8	110	28	50	37	10	33
403.H10.1	SK 40	10	110	30	50	42	10	37
403.H12.1	SK 40	12	110	32	50	47	10	42
403.H14.1	SK 40	14	110	34	50	47	10	42
403.H16.1	SK 40	16	110	38	50	52	10	42
403.H18.1	SK 40	18	110	40	50	52	10	47
403.H20.1	SK 40	20	110	42	50	52	10	47

Lieferumfang: Mit Spannschlüssel

Delivery: With wrench

Livraison: Avec clé de serrage

l₁ = max. Einstecktiefe

l₁ = max. clamping depth

l₁ = max. profondeur d'insertion

l₂ = max. Verstellweg

l₂ = max. length adjustment range

l₂ = max. course de réglage

