



## Kombi-Aufsteckfräserdorne DIN 6358

Combi shell mill holders DIN 6358

Porte-fraises à double usage DIN 6358

**DIN 69871 AD/B**



### Verwendung:

Zur Aufnahme von Walzen-, Walzenstirnfräsern oder Messerköpfen mit Längs- oder Quernut.

### Application:

For mounting milling cutters with transverse or longitudinal groove.

### Application:

Pour le serrage de fraises à rainure transversale ou à rainure longitudinale.

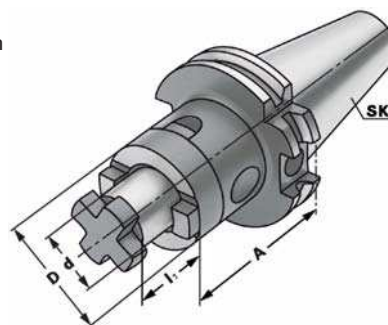

**G 6,3 12.000 min<sup>-1</sup>**

**≤ 0,005**

Bestell-Nr. Order no. Référence	SK	d <sub>h6</sub>	A	l <sub>1</sub>	D
302.10.16 *	SK 30	16	50	17	32
302.10.22 *	SK 30	22	50	19	40
302.10.27 *	SK 30	27	55	21	48
302.10.32 *	SK 30	32	60	24	58
403.10.16	SK 40	16	55	17	32
403.10.22	SK 40	22	55	19	40
403.10.27	SK 40	27	55	21	48
403.10.32	SK 40	32	60	24	58
403.10.40	SK 40	40	60	27	70
403.10.16.1	SK 40	16	100	17	32
403.10.22.1	SK 40	22	100	19	40
403.10.27.1	SK 40	27	100	21	48
403.10.32.1	SK 40	32	100	24	58
403.10.40.1	SK 40	40	100	27	70
503.10.16	SK 50	16	55	17	32
503.10.22	SK 50	22	55	19	40
503.10.27	SK 50	27	55	21	48
503.10.32	SK 50	32	55	24	58
503.10.40	SK 50	40	55	27	70
503.10.16.1	SK 50	16	100	17	32
503.10.22.1	SK 50	22	100	19	40
503.10.27.1	SK 50	27	100	21	48
503.10.32.1	SK 50	32	100	24	58
503.10.40.1	SK 50	40	100	27	70

\* DIN 69871 Form AD

\* DIN 69871 form AD

\* DIN 69871 forme AD

**Lieferumfang:** Mit Fräseranzugsschraube, Mitnehmerring und Passfeder

**Delivery:** With retaining screw, driving ring and feather key

**Livraison:** Avec vis de serrage, bague d'entraînement et clavette

