

Zubehör Spannzangen · Anzugsbolzen

*Accessories
Collets · Pull studs*

*Accessoires
Pinces · Tirettes*



Inhaltsverzeichnis

Index

Table de matières

DIN 69871



7.04



7.10

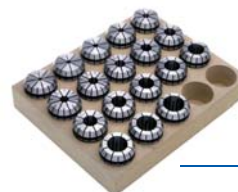

7.18



7.20



7.24



7.30



7.33



7.39



7.40



7.46



7.54



7.56



7.58



7.60



7.61



7.62



7.64



7.65



7.66



7.69



7.70

7.03



Spannzangen DIN 6388 B (ISO 10897 B) System OZ

Collets DIN 6388 B (ISO 10897 B) OZ-system

Pinces de serrage DIN 6388 B (ISO 10897 B) système OZ



Verwendung:

Zur Aufnahme von Werkzeugen mit Zylinderschaft in Spannfutter DIN 6391.

Für höchste radiale und axiale Belastungen.

Application:

For mounting straight-shank tools in collet chucks DIN 6391.

For highest axial and radial loading.

Application:

Pour le serrage d'outils avec queue cylindrique dans mandrins à pinces DIN 6391.

Pour une charge radiale et axiale maximale.

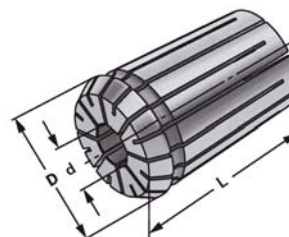

≤ 0,015

Bestell-Nr. Order no. Référence	Größe Size Taille	d	D	L
415E-02	OZ 16	2 – 1,5	25,5	40
415E-03	OZ 16	3 – 2,5	25,5	40
415E-04	OZ 16	4 – 3,5	25,5	40
415E-05	OZ 16	5 – 4,5	25,5	40
415E-06	OZ 16	6 – 5,5	25,5	40
415E-07	OZ 16	7 – 6,5	25,5	40
415E-08	OZ 16	8 – 7,5	25,5	40
415E-09	OZ 16	9 – 8,5	25,5	40
415E-10	OZ 16	10 – 9,5	25,5	40
415E-11	OZ 16	11 – 10,5	25,5	40
415E-12	OZ 16	12 – 11,5	25,5	40
415E-13	OZ 16	13 – 12,5	25,5	40
415E-14	OZ 16	14 – 13,5	25,5	40
415E-15	OZ 16	15 – 14,5	25,5	40
415E-16	OZ 16	16 – 15,5	25,5	40



Präzisionsspannzangen DIN 6388 B (ISO 10897 B) System OZ

Precision collets DIN 6388 B (ISO 10897 B) OZ-system

Pincès de serrage de précision DIN 6388 B (ISO 10897 B) système OZ



Verwendung:

Zur Aufnahme von Werkzeugen mit Zylinderschaft in Spannfutter DIN 6391.

Für Anwendungen im HSC-Bereich und für hochpräzise Bearbeitungsergebnisse.

Application:

For mounting straight-shank tools in collet chucks DIN 6391. To use for high speed cutting and high precision milling.

Application:

Pour le serrage d'outils avec queue cylindrique dans mandrins à pincès DIN 6391.

Pour l'usage dans le coupage à grande vitesse et dans l'usinage à grande précision.

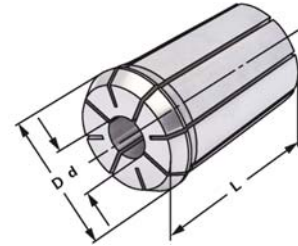

≤ 0,005

Bestell-Nr. Order no. Référence	Größe Size Taille	d	D	L
415EP-02	OZ 16	2 – 1,5	25,5	40
415EP-03	OZ 16	3 – 2,5	25,5	40
415EP-04	OZ 16	4 – 3,5	25,5	40
415EP-05	OZ 16	5 – 4,5	25,5	40
415EP-06	OZ 16	6 – 5,5	25,5	40
415EP-07	OZ 16	7 – 6,5	25,5	40
415EP-08	OZ 16	8 – 7,5	25,5	40
415EP-09	OZ 16	9 – 8,5	25,5	40
415EP-10	OZ 16	10 – 9,5	25,5	40
415EP-11	OZ 16	11 – 10,5	25,5	40
415EP-12	OZ 16	12 – 11,5	25,5	40
415EP-13	OZ 16	13 – 12,5	25,5	40
415EP-14	OZ 16	14 – 13,5	25,5	40
415EP-15	OZ 16	15 – 14,5	25,5	40
415EP-16	OZ 16	16 – 15,5	25,5	40





Spannzangen DIN 6388 B (ISO 10897 B) System OZ

Collets DIN 6388 B (ISO 10897 B) OZ-system

Pinces de serrage DIN 6388 B (ISO 10897 B) système OZ



Verwendung:

Zur Aufnahme von Werkzeugen mit Zylinderschaft in Spannfutter DIN 6391.

Für höchste radiale und axiale Belastungen.

Application:

For mounting straight-shank tools in collet chucks DIN 6391.

For highest axial and radial loading.

Application:

Pour le serrage d'outils avec queue cylindrique dans mandrins à pinces DIN 6391.

Pour une charge radiale et axiale maximale.

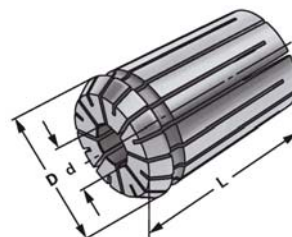

≤ 0,015

Bestell-Nr. Order no. Référence	Größe Size Taille	d	D	L
462E-02	OZ 25	2 – 1,5	35,05	52
462E-03	OZ 25	3 – 2,5	35,05	52
462E-04	OZ 25	4 – 3,5	35,05	52
462E-05	OZ 25	5 – 4,5	35,05	52
462E-06	OZ 25	6 – 5,5	35,05	52
462E-07	OZ 25	7 – 6,5	35,05	52
462E-08	OZ 25	8 – 7,5	35,05	52
462E-09	OZ 25	9 – 8,5	35,05	52
462E-10	OZ 25	10 – 9,5	35,05	52
462E-11	OZ 25	11 – 10,5	35,05	52
462E-12	OZ 25	12 – 11,5	35,05	52
462E-13	OZ 25	13 – 12,5	35,05	52
462E-14	OZ 25	14 – 13,5	35,05	52
462E-15	OZ 25	15 – 14,5	35,05	52
462E-16	OZ 25	16 – 15,5	35,05	52
462E-17	OZ 25	17 – 16,5	35,05	52
462E-18	OZ 25	18 – 17,5	35,05	52
462E-19	OZ 25	19 – 18,5	35,05	52
462E-20	OZ 25	20 – 19,5	35,05	52
462E-21	OZ 25	21 – 20,5	35,05	52
462E-22	OZ 25	22 – 21,5	35,05	52
462E-23	OZ 25	23 – 22,5	35,05	52
462E-24	OZ 25	24 – 23,5	35,05	52
462E-25	OZ 25	25 – 24,5	35,05	52



Präzisionsspannzangen DIN 6388 B (ISO 10897 B) System OZ

Precision collets DIN 6388 B (ISO 10897 B) OZ-system

Pincès de serrage de précision DIN 6388 B (ISO 10897 B) système OZ



Verwendung:

Zur Aufnahme von Werkzeugen mit Zylinderschaft in Spannfutter DIN 6391.

Für Anwendungen im HSC-Bereich und für hochpräzise Bearbeitungsergebnisse.

Application:

For mounting straight-shank tools in collet chucks DIN 6391. To use for high speed cutting and high precision milling.

Application:

Pour le serrage d'outils avec queue cylindrique dans mandrins à pincès DIN 6391.

Pour l'usage dans le coupage à grande vitesse et dans l'usinage à grande précision.

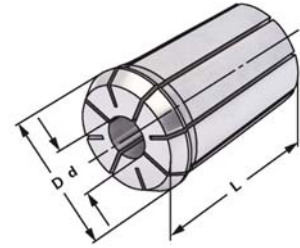

≤ 0,005

Bestell-Nr. Order no. Référence	Größe Size Taille	d	D	L
462EP-02	OZ 25	2 – 1,5	35,05	52
462EP-03	OZ 25	3 – 2,5	35,05	52
462EP-04	OZ 25	4 – 3,5	35,05	52
462EP-05	OZ 25	5 – 4,5	35,05	52
462EP-06	OZ 25	6 – 5,5	35,05	52
462EP-07	OZ 25	7 – 6,5	35,05	52
462EP-08	OZ 25	8 – 7,5	35,05	52
462EP-09	OZ 25	9 – 8,5	35,05	52
462EP-10	OZ 25	10 – 9,5	35,05	52
462EP-11	OZ 25	11 – 10,5	35,05	52
462EP-12	OZ 25	12 – 11,5	35,05	52
462EP-13	OZ 25	13 – 12,5	35,05	52
462EP-14	OZ 25	14 – 13,5	35,05	52
462EP-15	OZ 25	15 – 14,5	35,05	52
462EP-16	OZ 25	16 – 15,5	35,05	52
462EP-17	OZ 25	17 – 16,5	35,05	52
462EP-18	OZ 25	18 – 17,5	35,05	52
462EP-19	OZ 25	19 – 18,5	35,05	52
462EP-20	OZ 25	20 – 19,5	35,05	52
462EP-21	OZ 25	21 – 20,5	35,05	52
462EP-22	OZ 25	22 – 21,5	35,05	52
462EP-23	OZ 25	23 – 22,5	35,05	52
462EP-24	OZ 25	24 – 23,5	35,05	52
462EP-25	OZ 25	25 – 24,5	35,05	52





Spannzangen DIN 6388 B (ISO 10897 B) System OZ

Collets DIN 6388 B (ISO 10897 B) OZ-system

Pinces de serrage DIN 6388 B (ISO 10897 B) système OZ



Verwendung:

Zur Aufnahme von Werkzeugen mit Zylinderschaft in Spannfutter DIN 6391.

Für höchste radiale und axiale Belastungen.

Application:

For mounting straight-shank tools in collet chucks DIN 6391.

For highest axial and radial loading.

Application:

Pour le serrage d'outils avec queue cylindrique dans mandrins à pinces DIN 6391.

Pour une charge radiale et axiale maximale.

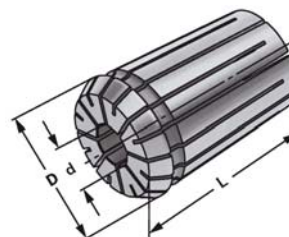

≤ 0,015

Bestell-Nr. Order no. Référence	Größe Size Taille	d	D	L
467E-03	OZ 32	3 – 2,5	43,7	60
467E-04	OZ 32	4 – 3,5	43,7	60
467E-05	OZ 32	5 – 4,5	43,7	60
467E-06	OZ 32	6 – 5,5	43,7	60
467E-07	OZ 32	7 – 6,5	43,7	60
467E-08	OZ 32	8 – 7,5	43,7	60
467E-09	OZ 32	9 – 8,5	43,7	60
467E-10	OZ 32	10 – 9,5	43,7	60
467E-11	OZ 32	11 – 10,5	43,7	60
467E-12	OZ 32	12 – 11,5	43,7	60
467E-13	OZ 32	13 – 12,5	43,7	60
467E-14	OZ 32	14 – 13,5	43,7	60
467E-15	OZ 32	15 – 14,5	43,7	60
467E-16	OZ 32	16 – 15,5	43,7	60
467E-17	OZ 32	17 – 16,5	43,7	60
467E-18	OZ 32	18 – 17,5	43,7	60
467E-19	OZ 32	19 – 18,5	43,7	60
467E-20	OZ 32	20 – 19,5	43,7	60
467E-21	OZ 32	21 – 20,5	43,7	60
467E-22	OZ 32	22 – 21,5	43,7	60
467E-23	OZ 32	23 – 22,5	43,7	60
467E-24	OZ 32	24 – 23,5	43,7	60
467E-25	OZ 32	25 – 24,5	43,7	60
467E-26	OZ 32	26 – 25,5	43,7	60
467E-27	OZ 32	27 – 26,5	43,7	60
467E-28	OZ 32	28 – 27,5	43,7	60
467E-29	OZ 32	29 – 28,5	43,7	60
467E-30	OZ 32	30 – 29,5	43,7	60
467E-31	OZ 32	31 – 30,5	43,7	60
467E-32	OZ 32	32 – 31,5	43,7	60



Präzisionsspannzangen DIN 6388 B (ISO 10897 B) System OZ

Precision collets DIN 6388 B (ISO 10897 B) OZ-system

Pinces de serrage de précision DIN 6388 B (ISO 10897 B) système OZ



Verwendung:

Zur Aufnahme von Werkzeugen mit Zylinderschaft in Spannfutter DIN 6391.

Für Anwendungen im HSC-Bereich und für hochpräzise Bearbeitungsergebnisse.

Application:

For mounting straight-shank tools in collet chucks DIN 6391. To use for high speed cutting and high precision milling.

Application:

Pour le serrage d'outils avec queue cylindrique dans mandrins à pinces DIN 6391.

Pour l'usage dans le coupage à grande vitesse et dans l'usinage à grande précision.

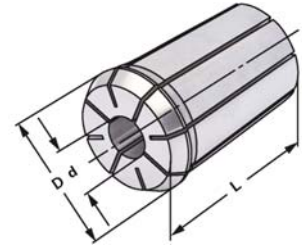

≤ 0,005

Bestell-Nr. Order no. Référence	Größe Size Taille	d	D	L
467EP-03	OZ 32	3 – 2,5	43,7	60
467EP-04	OZ 32	4 – 3,5	43,7	60
467EP-05	OZ 32	5 – 4,5	43,7	60
467EP-06	OZ 32	6 – 5,5	43,7	60
467EP-07	OZ 32	7 – 6,5	43,7	60
467EP-08	OZ 32	8 – 7,5	43,7	60
467EP-09	OZ 32	9 – 8,5	43,7	60
467EP-10	OZ 32	10 – 9,5	43,7	60
467EP-11	OZ 32	11 – 10,5	43,7	60
467EP-12	OZ 32	12 – 11,5	43,7	60
467EP-13	OZ 32	13 – 12,5	43,7	60
467EP-14	OZ 32	14 – 13,5	43,7	60
467EP-15	OZ 32	15 – 14,5	43,7	60
467EP-16	OZ 32	16 – 15,5	43,7	60
467EP-17	OZ 32	17 – 16,5	43,7	60
467EP-18	OZ 32	18 – 17,5	43,7	60
467EP-19	OZ 32	19 – 18,5	43,7	60
467EP-20	OZ 32	20 – 19,5	43,7	60
467EP-21	OZ 32	21 – 20,5	43,7	60
467EP-22	OZ 32	22 – 21,5	43,7	60
467EP-23	OZ 32	23 – 22,5	43,7	60
467EP-24	OZ 32	24 – 23,5	43,7	60
467EP-25	OZ 32	25 – 24,5	43,7	60
467EP-26	OZ 32	26 – 25,5	43,7	60
467EP-27	OZ 32	27 – 26,5	43,7	60
467EP-28	OZ 32	28 – 27,5	43,7	60
467EP-29	OZ 32	29 – 28,5	43,7	60
467EP-30	OZ 32	30 – 29,5	43,7	60
467EP-31	OZ 32	31 – 30,5	43,7	60
467EP-32	OZ 32	32 – 31,5	43,7	60





Spannzangen DIN 6499 B (ISO 15488 B) System ER

Collets DIN 6499 B (ISO 15488 B) ER-system

Pincès de serrage DIN 6499 B (ISO 15488 B) système ER



Verwendung:

Zur Aufnahme von Werkzeugen mit Zylinderschaft in Spannfutter DIN 6499.

Application:

For mounting straight-shank tools in collet chucks DIN 6499.

Application:

Pour le serrage d'outils avec queue cylindrique dans mandrins à pincès DIN 6499.

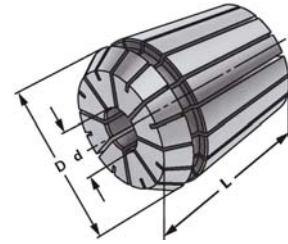

≤ 0,015

Bestell-Nr. Order no. Référence	Größe Size Taille	d	D	L
426E-01	ER 16	1 – 0,5	17	27
426E-02	ER 16	2 – 1,0	17	27
426E-03	ER 16	3 – 2,0	17	27
426E-04	ER 16	4 – 3,0	17	27
426E-05	ER 16	5 – 4,0	17	27
426E-06	ER 16	6 – 5,0	17	27
426E-07	ER 16	7 – 6,0	17	27
426E-08	ER 16	8 – 7,0	17	27
426E-09	ER 16	9 – 8,0	17	27
426E-10	ER 16	10 – 9,0	17	27

Hinweis: Hohe Flexibilität: Großer Spannbereich bis –1 mm

Note: High flexibility: Large holding capacity up to –1 mm

Observation: Grande capacité de serrage jusqu'à –1 mm



Präzisionsspannzangen DIN 6499 B (ISO 15488 B) System ER

Precision collets DIN 6499 B (ISO 15488 B) ER-system

Pinces de serrage de précision DIN 6499 B (ISO 15488 B) système ER



Verwendung:

Zur Aufnahme von Werkzeugen mit Zylinderschaft in Spannfutter DIN 6499.

Für Anwendungen im HSC-Bereich und für hochpräzise Bearbeitungsergebnisse.

Application:

For mounting straight-shank tools in collet chucks DIN 6499. To use for high speed cutting and high precision milling.

Application:

Pour le serrage d'outils avec queue cylindrique dans mandrins à pinces DIN 6499. Pour l'usage dans le coupage à grande vitesse et dans l'usinage à grande précision.

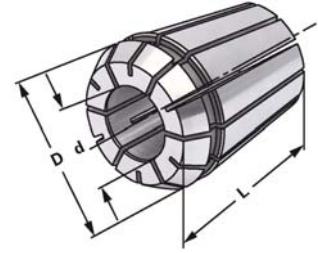

≤ 0,005

Bestell-Nr. Order no. Référence	Größe Size Taille	d	D	L
426EP-01	ER 16	1 – 0,5	17	27
426EP-02	ER 16	2 – 1,0	17	27
426EP-03	ER 16	3 – 2,0	17	27
426EP-04	ER 16	4 – 3,0	17	27
426EP-05	ER 16	5 – 4,0	17	27
426EP-06	ER 16	6 – 5,0	17	27
426EP-07	ER 16	7 – 6,0	17	27
426EP-08	ER 16	8 – 7,0	17	27
426EP-09	ER 16	9 – 8,0	17	27
426EP-10	ER 16	10 – 9,0	17	27

Hinweis: Hohe Flexibilität: Großer Spannbereich bis –1 mm

Note: High flexibility: Large holding capacity up to –1 mm

Observation: Grande capacité de serrage jusqu'à –1 mm





Spannzangen DIN 6499 B (ISO 15488 B) System ER

Collets DIN 6499 B (ISO 15488 B) ER-system

Pinces de serrage DIN 6499 B (ISO 15488 B) système ER



Verwendung:

Zur Aufnahme von Werkzeugen mit Zylinderschaft in Spannfutter DIN 6499.

Application:

For mounting straight-shank tools in collet chucks DIN 6499.

Application:

Pour le serrage d'outils avec queue cylindrique dans mandrins à pinces DIN 6499.

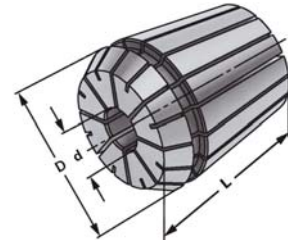

≤ 0,015

Bestell-Nr. Order no. Référence	Größe Size Taille	d	D	L
430E-02	ER 25	2 – 1,5	26	34
430E-03	ER 25	3 – 2,0	26	34
430E-04	ER 25	4 – 3,0	26	34
430E-05	ER 25	5 – 4,0	26	34
430E-06	ER 25	6 – 5,0	26	34
430E-07	ER 25	7 – 6,0	26	34
430E-08	ER 25	8 – 7,0	26	34
430E-09	ER 25	9 – 8,0	26	34
430E-10	ER 25	10 – 9,0	26	34
430E-11	ER 25	11 – 10,0	26	34
430E-12	ER 25	12 – 11,0	26	34
430E-13	ER 25	13 – 12,0	26	34
430E-14	ER 25	14 – 13,0	26	34
430E-15	ER 25	15 – 14,0	26	34
430E-16	ER 25	16 – 15,0	26	34

Hinweis: Hohe Flexibilität: Großer Spannbereich bis –1 mm

Note: High flexibility: Large holding capacity up to –1 mm

Observation: Grande capacité de serrage jusqu'à –1 mm

7



7.12

Präzisionsspannzangen DIN 6499 B (ISO 15488 B) System ER

Precision collets DIN 6499 B (ISO 15488 B) ER-system

Pinces de serrage de précision DIN 6499 B (ISO 15488 B) système ER



Verwendung:

Zur Aufnahme von Werkzeugen mit Zylinderschaft in Spannfutter DIN 6499.

Für Anwendungen im HSC-Bereich und für hochpräzise Bearbeitungsergebnisse.

Application:

For mounting straight-shank tools in collet chucks DIN 6499. To use for high speed cutting and high precision milling.

Application:

Pour le serrage d'outils avec queue cylindrique dans mandrins à pinces DIN 6499.

Pour l'usage dans le coupage à grande vitesse et dans l'usinage à grande précision.

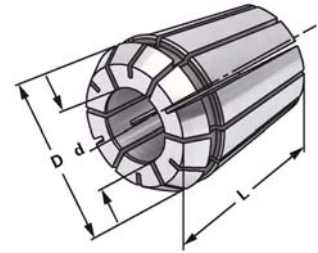

≤ 0,005

Bestell-Nr. Order no. Référence	Größe Size Taille	d	D	L
430EP-02	ER 25	2 – 1,5	26	34
430EP-03	ER 25	3 – 2,0	26	34
430EP-04	ER 25	4 – 3,0	26	34
430EP-05	ER 25	5 – 4,0	26	34
430EP-06	ER 25	6 – 5,0	26	34
430EP-07	ER 25	7 – 6,0	26	34
430EP-08	ER 25	8 – 7,0	26	34
430EP-09	ER 25	9 – 8,0	26	34
430EP-10	ER 25	10 – 9,0	26	34
430EP-11	ER 25	11 – 10,0	26	34
430EP-12	ER 25	12 – 11,0	26	34
430EP-13	ER 25	13 – 12,0	26	34
430EP-14	ER 25	14 – 13,0	26	34
430EP-15	ER 25	15 – 14,0	26	34
430EP-16	ER 25	16 – 15,0	26	34

Hinweis: Hohe Flexibilität: Großer Spannbereich bis –1 mm
Note: High flexibility: Large holding capacity up to –1 mm
Observation: Grande capacité de serrage jusqu'à –1 mm





Spannzangen DIN 6499 B (ISO 15488 B) System ER

Collets DIN 6499 B (ISO 15488 B) ER-system

Pincès de serrage DIN 6499 B (ISO 15488 B) système ER



Verwendung:

Zur Aufnahme von Werkzeugen mit Zylinderschaft in Spannfutter DIN 6499.

Application:

For mounting straight-shank tools in collet chucks DIN 6499.

Application:

Pour le serrage d'outils avec queue cylindrique dans mandrins à pincès DIN 6499.

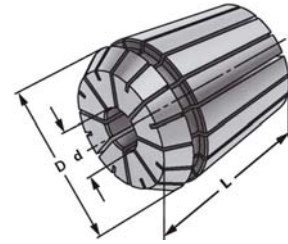

≤ 0,015

Bestell-Nr. Order no. Référence	Größe Size Taille	d	D	L
470E-02	ER 32	2 – 1,5	33	40
470E-03	ER 32	3 – 2,0	33	40
470E-04	ER 32	4 – 3,0	33	40
470E-05	ER 32	5 – 4,0	33	40
470E-06	ER 32	6 – 5,0	33	40
470E-07	ER 32	7 – 6,0	33	40
470E-08	ER 32	8 – 7,0	33	40
470E-09	ER 32	9 – 8,0	33	40
470E-10	ER 32	10 – 9,0	33	40
470E-11	ER 32	11 – 10,0	33	40
470E-12	ER 32	12 – 11,0	33	40
470E-13	ER 32	13 – 12,0	33	40
470E-14	ER 32	14 – 13,0	33	40
470E-15	ER 32	15 – 14,0	33	40
470E-16	ER 32	16 – 15,0	33	40
470E-17	ER 32	17 – 16,0	33	40
470E-18	ER 32	18 – 17,0	33	40
470E-19	ER 32	19 – 18,0	33	40
470E-20	ER 32	20 – 19,0	33	40

Hinweis: Hohe Flexibilität: Großer Spannbereich bis –1 mm
Note: High flexibility: Large holding capacity up to –1 mm
Observation: Grande capacité de serrage jusqu'à –1 mm

7



7.14

Präzisionsspannzangen DIN 6499 B (ISO 15488 B) System ER

Precision collets DIN 6499 B (ISO 15488 B) ER-system

Pinces de serrage de précision DIN 6499 B (ISO 15488 B) système ER



Verwendung:

Zur Aufnahme von Werkzeugen mit Zylinderschaft in Spannfutter DIN 6499.

Für Anwendungen im HSC-Bereich und für hochpräzise Bearbeitungsergebnisse.

Application:

For mounting straight-shank tools in collet chucks DIN 6499. To use for high speed cutting and high precision milling.

Application:

Pour le serrage d'outils avec queue cylindrique dans mandrins à pinces DIN 6499.

Pour l'usage dans le coupage à grande vitesse et dans l'usinage à grande précision.

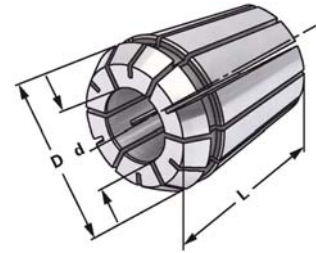

≤ 0,005

Bestell-Nr. Order no. Référence	Größe Size Taille	d	D	L
470EP-02	ER 32	2 – 1,5	33	40
470EP-03	ER 32	3 – 2,0	33	40
470EP-04	ER 32	4 – 3,0	33	40
470EP-05	ER 32	5 – 4,0	33	40
470EP-06	ER 32	6 – 5,0	33	40
470EP-07	ER 32	7 – 6,0	33	40
470EP-08	ER 32	8 – 7,0	33	40
470EP-09	ER 32	9 – 8,0	33	40
470EP-10	ER 32	10 – 9,0	33	40
470EP-11	ER 32	11 – 10,0	33	40
470EP-12	ER 32	12 – 11,0	33	40
470EP-13	ER 32	13 – 12,0	33	40
470EP-14	ER 32	14 – 13,0	33	40
470EP-15	ER 32	15 – 14,0	33	40
470EP-16	ER 32	16 – 15,0	33	40
470EP-17	ER 32	17 – 16,0	33	40
470EP-18	ER 32	18 – 17,0	33	40
470EP-19	ER 32	19 – 18,0	33	40
470EP-20	ER 32	20 – 19,0	33	40

Hinweis: Hohe Flexibilität: Großer Spannbereich bis –1 mm
Note: High flexibility: Large holding capacity up to –1 mm
Observation: Grande capacité de serrage jusqu'à –1 mm





Spannzangen DIN 6499 B (ISO 15488 B) System ER

Collets DIN 6499 B (ISO 15488 B) ER-system

Pinces de serrage DIN 6499 B (ISO 15488 B) système ER



Verwendung:

Zur Aufnahme von Werkzeugen mit Zylinderschaft in Spannfutter DIN 6499.

Application:

For mounting straight-shank tools in collet chucks DIN 6499.

Application:

Pour le serrage d'outils avec queue cylindrique dans mandrins à pinces DIN 6499.

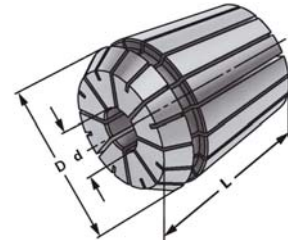

≤ 0,015

Bestell-Nr. Order no. Référence	Größe Size Taille	d	D	L
472E-03	ER 40	3 – 2,5	41	46
472E-04	ER 40	4 – 3,0	41	46
472E-05	ER 40	5 – 4,0	41	46
472E-06	ER 40	6 – 5,0	41	46
472E-07	ER 40	7 – 6,0	41	46
472E-08	ER 40	8 – 7,0	41	46
472E-09	ER 40	9 – 8,0	41	46
472E-10	ER 40	10 – 9,0	41	46
472E-11	ER 40	11 – 10,0	41	46
472E-12	ER 40	12 – 11,0	41	46
472E-13	ER 40	13 – 12,0	41	46
472E-14	ER 40	14 – 13,0	41	46
472E-15	ER 40	15 – 14,0	41	46
472E-16	ER 40	16 – 15,0	41	46
472E-17	ER 40	17 – 16,0	41	46
472E-18	ER 40	18 – 17,0	41	46
472E-19	ER 40	19 – 18,0	41	46
472E-20	ER 40	20 – 19,0	41	46
472E-21	ER 40	21 – 20,0	41	46
472E-22	ER 40	22 – 21,0	41	46
472E-23	ER 40	23 – 22,0	41	46
472E-24	ER 40	24 – 23,0	41	46
472E-25	ER 40	25 – 24,0	41	46
472E-26	ER 40	26 – 25,0	41	46

Hinweis: Hohe Flexibilität: Großer Spannbereich bis –1 mm
Note: High flexibility: Large holding capacity up to –1 mm
Observation: Grande capacité de serrage jusqu'à –1 mm



Präzisionsspannzangen DIN 6499 B (ISO 15488 B) System ER

Precision collets DIN 6499 B (ISO 15488 B) ER-system

Pinces de serrage de précision DIN 6499 B (ISO 15488 B) système ER



Verwendung:

Zur Aufnahme von Werkzeugen mit Zylinderschaft in Spannfutter DIN 6499.

Für Anwendungen im HSC-Bereich und für hochpräzise Bearbeitungsergebnisse.

Application:

For mounting straight-shank tools in collet chucks DIN 6499. To use for high speed cutting and high precision milling.

Application:

Pour le serrage d'outils avec queue cylindrique dans mandrins à pinces DIN 6499.

Pour l'usage dans le coupage à grande vitesse et dans l'usinage à grande précision.

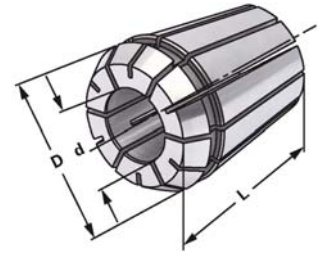

≤ 0,005

Bestell-Nr. Order no. Référence	Größe Size Taille	d	D	L
472EP-03	ER 40	3 – 2,5	41	46
472EP-04	ER 40	4 – 3,0	41	46
472EP-05	ER 40	5 – 4,0	41	46
472EP-06	ER 40	6 – 5,0	41	46
472EP-07	ER 40	7 – 6,0	41	46
472EP-08	ER 40	8 – 7,0	41	46
472EP-09	ER 40	9 – 8,0	41	46
472EP-10	ER 40	10 – 9,0	41	46
472EP-11	ER 40	11 – 10,0	41	46
472EP-12	ER 40	12 – 11,0	41	46
472EP-13	ER 40	13 – 12,0	41	46
472EP-14	ER 40	14 – 13,0	41	46
472EP-15	ER 40	15 – 14,0	41	46
472EP-16	ER 40	16 – 15,0	41	46
472EP-17	ER 40	17 – 16,0	41	46
472EP-18	ER 40	18 – 17,0	41	46
472EP-19	ER 40	19 – 18,0	41	46
472EP-20	ER 40	20 – 19,0	41	46
472EP-21	ER 40	21 – 20,0	41	46
472EP-22	ER 40	22 – 21,0	41	46
472EP-23	ER 40	23 – 22,0	41	46
472EP-24	ER 40	24 – 23,0	41	46
472EP-25	ER 40	25 – 24,0	41	46
472EP-26	ER 40	26 – 25,0	41	46

Hinweis: Hohe Flexibilität: Großer Spannbereich bis –1 mm
Note: High flexibility: Large holding capacity up to –1 mm
Observation: Grande capacité de serrage jusqu'à –1 mm





Spannzangensätze im Holzsockel

Collet sets in wooden sockets

Jeux de pinces dans socles en bois



Verwendung:

Zur Aufnahme von Werkzeugen mit Zylinderschaft in Spannfutter DIN 6388/DIN 6499.

Application:

For mounting straight-shank tools in collet chucks DIN 6388/DIN 6499.

Application:

Pour le serrage d'outils avec queue cylindrique dans mandrins à pinces DIN 6388/DIN 6499.

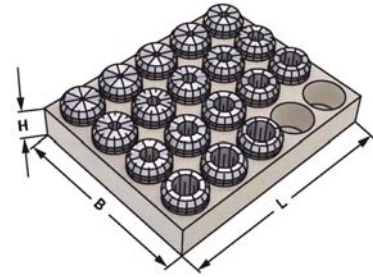

≤ 0,015

Bestell-Nr. Order no. Référence	Abmessung Size Dimension		L	B	H
415E - S	415E (OZ 16; 15 tlg.) 2-3-4-5-6-7-8-9-10-11-12-13-14-15-16		150	195	25
462E - S	462E (OZ 25; 15 tlg.) 4-5-6-7-8-9-10-11-12-14-16-18-20-22-25		290	240	30
467E - S	467E (OZ 32; 16 tlg.) 5-6-7-8-10-12-14-16-18-20-22-24-25-28-30-32		290	240	30
426E - S	426E (ER 16; 10 tlg.) 1-2-3-4-5-6-7-8-9-10		130	50	25
430E - S	430E (ER 25; 15 tlg.) 2-3-4-5-6-7-8-9-10-11-12-13-14-15-16		150	195	25
470E - S	470E (ER 32; 18 tlg.) 3-4-5-6-7-8-9-10-11-12-13-14-15-16-17-18-19-20		190	150	30
472E - S	472E (ER 40; 23 tlg.) 4-5-6-7-8-9-10-11-12-13-14-15-16-17-18-19-20-21-22-23-24-25-26		290	195	25

Präzisionsspannzangensätze im Holzsockel

Precision collet sets in wooden sockets

Jeux de pinces de précision dans socles en bois



Verwendung:

Zur Aufnahme von Werkzeugen mit Zylinder-schaft in Spannfutter DIN 6388/DIN 6499. Für Anwendungen im HSC-Bereich und für hochpräzise Bearbeitungsergebnisse.

Application:

For mounting straight-shank tools in collet chucks DIN 6388/DIN 6499. To use for high speed cutting and high precision milling.

Application:

Pour le serrage d'outils avec queue cylindrique dans mandrins à pinces DIN 6388/DIN 6499. Pour l'usage dans le coupage à grande vitesse et dans l'usinage à grande précision.

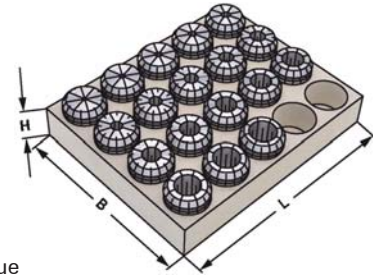

≤ 0,005

Bestell-Nr. Order no. Référence	Abmessung Size Dimension	L	B	H
415EP - S	415E (OZ 16; 15 tlg.) 2-3-4-5-6-7-8-9-10-11-12-13-14-15-16	150	195	25
462EP - S	462E (OZ 25; 15 tlg.) 4-5-6-7-8-9-10-11-12-14-16-18-20-22-25	290	240	30
467EP - S	467E (OZ 32; 16 tlg.) 5-6-7-8-10-12-14-16-18-20-22-24-25-28-30-32	290	240	30
426EP - S	426E (ER 16; 10 tlg.) 1-2-3-4-5-6-7-8-9-10	130	50	25
430EP - S	430E (ER 25; 15 tlg.) 2-3-4-5-6-7-8-9-10-11-12-13-14-15-16	150	195	25
470EP - S	470E (ER 32; 18 tlg.) 3-4-5-6-7-8-9-10-11-12-13-14-15-16-17-18-19-20	190	150	30
472EP - S	472E (ER 40; 23 tlg.) 4-5-6-7-8-9-10-11-12-13-14-15-16-17-18-19-20-21-22-23-24-25-26	290	195	25



Spannzangensätze im Holzkasten

Collet sets in wooden boxes

Jeux de pinces dans coffrets en bois



Verwendung:
Satzzusammenstellung von Spannzangen.

Application:
Collection of collets.

Application:
Composition de pinces.



≤ 0,015

Bestell-Nr. Order no. Référence	Abmessung Size Dimension	L	B	H
701.415.1	415E (OZ 16; 15 St.) 2-3-4-5-6-7-8-9-10-11-12-13-14-15-16	360	235	70
701.462.1	462E (OZ 25; 15 St.) 4-5-6-7-8-9-10-11-12-14-16-18-20-22-25	360	235	70
701.467.1	467E (OZ 32; 16 St.) 5-6-7-8-10-12-14-16-18-20-22-24-25-28-30-32	360	235	70
701.426.1	426E (ER 16; 10 St.) 1-2-3-4-5-6-7-8-9-10	360	235	70
701.430.1	430E (ER 25; 15 St.) 2-3-4-5-6-7-8-9-10-11-12-13-14-15-16	360	235	70
701.470.1	470E (ER 32; 15 St.) 3-4-5-6-7-8-9-10-11-12-14-15-16-18-20	360	235	70
701.472.1	472E (ER 40; 16 St.) 4-5-6-7-8-9-10-11-12-14-16-18-20-22-24-26	360	235	70

Hinweis: Spannzangenfutter und Schlüssel sind getrennt zu bestellen.

Note: Collet chucks and wrenches to be ordered separately.

Observation: Mandrins à pinces et clés doivent être commandés séparément.

Präzisionsspannzangensätze im Holzkasten

Precision collet sets in wooden boxes

Jeux de pinces de précision dans coffrets en bois



Verwendung:
Satzzusammenstellung von Spannzangen.

Application:
Collection of collets.

Application:
Composition de pinces.

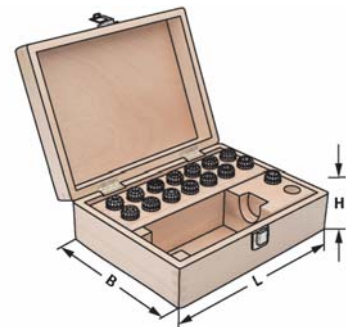

↗ ≤ 0,005

Bestell-Nr. Order no. Référence	Abmessung Size Dimension	L	B	H
701.415P.1	415E (OZ 16; 15 St.) 2-3-4-5-6-7-8-9-10-11-12-13-14-15-16	360	235	70
701.462P.1	462E (OZ 25; 15 St.) 4-5-6-7-8-9-10-11-12-14-16-18-20-22-25	360	235	70
701.467P.1	467E (OZ 32; 16 St.) 5-6-7-8-10-12-14-16-18-20-22-24-25-28-30-32	360	235	70
701.426P.1	426E (ER 16; 10 St.) 1-2-3-4-5-6-7-8-9-10	360	235	70
701.430P.1	430E (ER 25; 15 St.) 2-3-4-5-6-7-8-9-10-11-12-13-14-15-16	360	235	70
701.470P.1	470E (ER 32; 15 St.) 3-4-5-6-7-8-9-10-11-12-14-15-16-18-20	360	235	70
701.472P.1	472E (ER 40; 16 St.) 4-5-6-7-8-9-10-11-12-14-16-18-20-22-24-26	360	235	70

Hinweis: Spannzangenfutter und Schlüssel sind getrennt zu bestellen.

Note: *Collet chucks and wrenches to be ordered separately.*

Observation: Mandrins à pinces et clés doivent être commandés séparément.



Holzkästen, leer

Wooden boxes, empty
Coffrets en bois, vides



Verwendung:

Zur Aufbewahrung von Spannzangenfutter, Spanschlüssel und Spannzangen.

Application:

For the storage of collet chuck, wrench and collets.

Application:

Pour la conservation de mandrin à pinces, clé de serrage et pinces.



Bestell-Nr. Order no. Référence	Abmessung Size Dimension		Bohrungen Holes Trous	L	B	H
701.10	Gr. 10	ER 16	16	360	235	70
701.16	Gr. 16	ER 25 / OZ 16	16	360	235	70
701.20/25	Gr. 20/25	ER 32 / OZ 25	16	360	235	70
701.26/32	Gr. 26/32	ER 40 / OZ 32	16	360	235	70

Holzsockel, leer

Wooden sockets, empty
Socles en bois, vides



Verwendung:
Zur Aufbewahrung von Spannzangen.

Application:
For the storage of collets.

Application:
Pour la conservation de pinces.

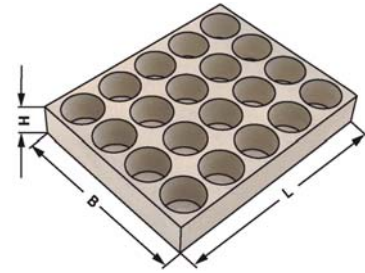

Bestell-Nr. Order no. Référence	Abmessung Size Dimension		Bohrungen Holes Trous	L	B	H
701.10.1	Gr. 10	ER 16	10	130	50	25
701.16.1	Gr. 16	ER 25 / OZ 16	20	190	155	40
701.20/25.1	Gr. 20/25	ER 32 / OZ 25	20	190	155	30
701.26/32.1	Gr. 26/32	ER 40 / OZ 32	30	290	240	30



Präzisionsspannzangen System KPS

Precision collets KPS-system

Pinces de serrage de précision système KPS



Verwendung:

Zur Aufnahme von Werkzeugen mit Zylinderschaft in Spannfutter System KPS.
Für Anwendungen im HSC-Bereich und für hochpräzise Bearbeitungsergebnisse.

Application:

For mounting straight-shank tools in collet chucks KPS-system. To use for high speed cutting and high precision milling.

Application:

Pour le serrage d'outils avec queue cylindrique dans mandrins à pinces système KPS.
Pour l'usage dans le coupage à grande vitesse et dans l'usinage à grande précision.

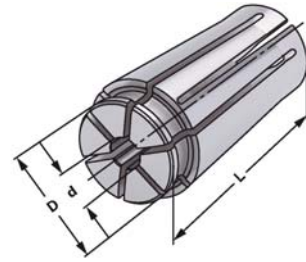

≤ 0,005

Bestell-Nr. Order no. Référence	Größe Size Taille	d	D	L
490EK-030	KPS 10	3	15,5	30,5
490EK-035	KPS 10	3,5	15,5	30,5
490EK-040	KPS 10	4	15,5	30,5
490EK-045	KPS 10	4,5	15,5	30,5
490EK-050	KPS 10	5	15,5	30,5
490EK-055	KPS 10	5,5	15,5	30,5
490EK-060	KPS 10	6	15,5	30,5
490EK-065	KPS 10	6,5	15,5	30,5
490EK-070	KPS 10	7	15,5	30,5
490EK-075	KPS 10	7,5	15,5	30,5
490EK-080	KPS 10	8	15,5	30,5
490EK-085	KPS 10	8,5	15,5	30,5
490EK-090	KPS 10	9	15,5	30,5
490EK-095	KPS 10	9,5	15,5	30,5
490EK-100	KPS 10	10	15,5	30,5
496EK-040	KPS 16	4	24,6	45
496EK-045	KPS 16	4,5	24,6	45
496EK-050	KPS 16	5	24,6	45
496EK-055	KPS 16	5,5	24,6	45
496EK-060	KPS 16	6	24,6	45
496EK-065	KPS 16	6,5	24,6	45
496EK-070	KPS 16	7	24,6	45
496EK-075	KPS 16	7,5	24,6	45
496EK-080	KPS 16	8	24,6	45
496EK-085	KPS 16	8,5	24,6	45
496EK-090	KPS 16	9	24,6	45
496EK-095	KPS 16	9,5	24,6	45
496EK-100	KPS 16	10	24,6	45
496EK-105	KPS 16	10,5	24,6	45
496EK-110	KPS 16	11	24,6	45
496EK-115	KPS 16	11,5	24,6	45
496EK-120	KPS 16	12	24,6	45
496EK-125	KPS 16	12,5	24,6	45
496EK-130	KPS 16	13	24,6	45
496EK-135	KPS 16	13,5	24,6	45
496EK-140	KPS 16	14	24,6	45
496EK-145	KPS 16	14,5	24,6	45
496EK-150	KPS 16	15	24,6	45
496EK-155	KPS 16	15,5	24,6	45
496EK-160	KPS 16	16	24,6	45

Montagehilfe System KPS

Collet extractor KPS-system

Moyen d'assemblage système KPS



Verwendung:

Zur Montage und Demontage der Spannzangen System KPS.

Application:

For the assembly and disassembly of collets KPS-system.

Application:

Pour l'assemblage et désassemblage de pinces de serrage système KPS.

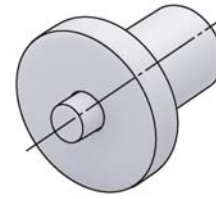

Bestell-Nr. Order no. Référence	Abmessung Size Dimension
490EK-183	KPS 10
496EK-183	KPS 16





Spannmutter System KPS

Clamping nuts KPS-system

Ecrous de serrage système KPS



Verwendung:
Für Spannzangen System KPS.

Application:
For collets KPS-system.

Application:
Pour pinces de serrage système KPS.

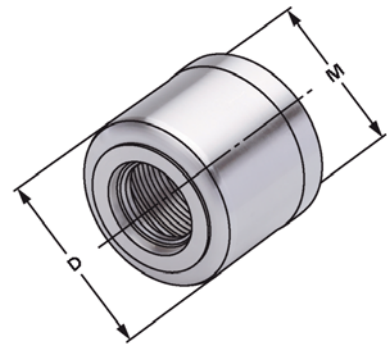

Bestell-Nr. Order no. Référence	Spannbereich Capacity Capacité	D	M
490EK-181	KPS 10	28	M21,5 × 1,0
496EK-181	KPS 16	40	M32,0 × 1,5



Spannschlüssel für Spannmuttern System KPS

Wrenches for clamping nuts KPS-system

Clés de serrage pour écrous de serrage système KPS



Verwendung:

Für Spannmuttern System KPS.

Application:

For clamping nuts KPS-system.

Application:

Pour écrous de serrage système KPS.

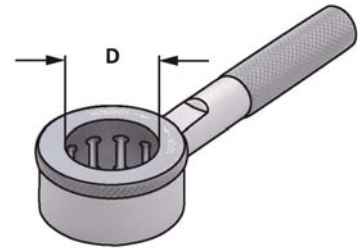

Bestell-Nr. Order no. Référence	Abmessung Size Dimension	D
490EK-182	KPS 10	28
496EK-182	KPS 16	40



Spannzangen DIN 6499 A (ISO 15488 A) System ER mit Innenvierkant für Gewindebohrer

Collets DIN 6499 A (ISO 15488 A) ER-system with square locking drive for tapping drills

Pinces de serrage DIN 6499 A (ISO 15488 A) système ER avec carré d'entraînement pour tarauds



Verwendung:

Für Maschinen mit steigungssynchronem Vorschub. Zur verdrehsicheren Spannung von Gewindebohrern.

Application:

For machines with rigid tapping.
For safe clamping of taps.

Application:

Pour machines avec broche synchronisée.
Pour le serrage stable de tarauds.

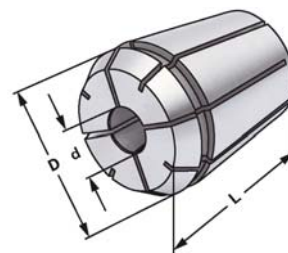

Bestell-Nr. Order no. Référence	Größe Size Taille	Schaft Shaft Queue	Vierkant Square Carré	D	L
426G-3527	ER 16	3,5	2,7	17	27,5
426G-43	ER 16	4	3	17	27,5
426G-4534	ER 16	4,5	3,4	17	27,5
426G-649	ER 16	6	4,9	17	27,5
426G-755	ER 16	7	5,5	17	27,5
426G-862	ER 16	8	6,2	17	27,5
430G-3527	ER 25	3,5	2,7	26	34
430G-43	ER 25	4	3	26	34
430G-4534	ER 25	4,5	3,4	26	34
430G-649	ER 25	6	4,9	26	34
430G-755	ER 25	7	5,5	26	34
430G-862	ER 25	8	6,2	26	34
430G-97	ER 25	9	7	26	34
430G-108	ER 25	10	8	26	34
430G-119	ER 25	11	9	26	34
430G-129	ER 25	12	9	26	34

Spannzangen DIN 6499 (ISO 15488) System ER, mit Innenvierkant für Gewindebohrer

Collets DIN 6499 (ISO 15488) ER-system with square locking drive for tapping drills

Pinces de serrage DIN 6499 (ISO 15488) système ER avec carré d'entraînement pour tarauds



Verwendung:

Für Maschinen mit steigungssynchronem Vorschub. Zur verkehrsichereren Spannung von Gewindebohrern.

Application:

For machines with rigid tapping.
For safe clamping of taps.

Application:

Pour machines avec broche synchronisée.
Pour le serrage stable de tarauds.

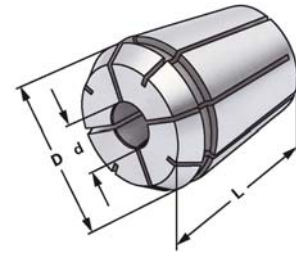

Bestell-Nr. Order no. Référence	Größe Size Taille	d Shaft Queue	Vierkant Square Carré	D	L
470G-4534	ER 32	4,5	3,4	33	40
470G-649	ER 32	6	4,9	33	40
470G-755	ER 32	7	5,5	33	40
470G-862	ER 32	8	6,2	33	40
470G-97	ER 32	9	7	33	40
470G-108	ER 32	10	8	33	40
470G-119	ER 32	11	9	33	40
470G-129	ER 32	12	9	33	40
470G-1411	ER 32	14	11	33	40
470G-1612	ER 32	16	12	33	40
472G-649	ER 40	6	4,9	41	46
472G-755	ER 40	7	5,5	41	46
472G-862	ER 40	8	6,2	41	46
472G-97	ER 40	9	7	41	46
472G-108	ER 40	10	8	41	46
472G-119	ER 40	11	9	41	46
472G-129	ER 40	12	9	41	46
472G-1411	ER 40	14	11	41	46
472G-1612	ER 40	16	12	41	46
472G-18145	ER 40	18	14,5	41	46
472G-2016	ER 40	20	16	41	46



Spannmuttern DIN 6388 D (ISO 10897) System OZ, kugelgelagerte Ausführung

Clamping nuts DIN 6388 D (ISO 10897) OZ-system, ball-bearing version

Ecrous de serrage DIN 6388 D (ISO 10897) système OZ, version roulement à billes



Verwendung:

Alle Spannzangen mit Außenform DIN 6388 (ISO 10897) können gespannt werden.

Application:

All collets with outside form DIN 6388 (ISO 10897) can be clamped.

Application:

Toutes les pinces avec une forme extérieure suivant DIN 6388 (ISO 10897) peuvent être serrées.

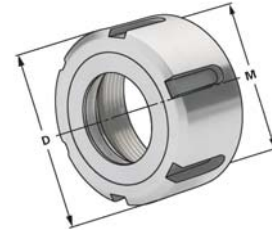

Bestell-Nr. Order no. Référence	Spannbereich Capacity Capacité	D	M
112.01.16	2 – 16 (OZ 16)	43	M33 × 1,5
112.01.25	2 – 25 (OZ 25)	60	M48 × 2
112.01.32	3 – 32 (OZ 32)	72	M60 × 2,5



Spannmuttern DIN 6499 (ISO 15488) System ER, Standardausführung mit Exzenterring, gewuchtet

Clamping nuts DIN 6499 (ISO 15488) ER-system, standard type with eccentric ring, balanced
Ecrous de serrage DIN 6499 (ISO 15488) système ER, version standard avec bague excentrique, équilibrés



Verwendung:

Alle Spannzangen mit Außenform DIN 6499 (ISO 15488) können gespannt werden.

Application:

All collets with outside form DIN 6499 (ISO 15488) can be clamped.

Application:

Toutes les pinces avec une forme extérieure suivant DIN 6499 (ISO 15488) peuvent être serrées.

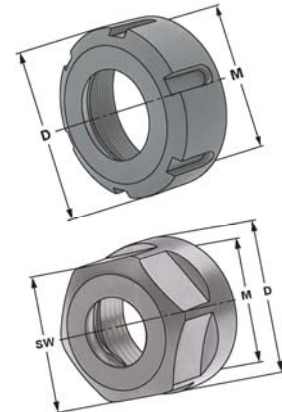

Bestell-Nr. Order no. Référence	Spannbereich Capacity Capacité	D	sw	M
110.02.10	1 – 10 (ER 16)	32		M22 × 1,5
110.02.10.6 *	1 – 10 (ER 16)	28	25	M22 × 1,5
110.02.16	2 – 16 (ER 25)	42		M32 × 1,5
110.02.20	2 – 20 (ER 32)	50		M40 × 1,5
110.02.26	3 – 26 (ER 40)	63		M50 × 1,5

* Sechskantmutter

* Hexagonal clamping nut

* Écrou hexagonal

Spannmuttern DIN 6499 (ISO 15488) System ER, gleitgelagerte Ausführung

Clamping nuts DIN 6499 (ISO 15488) ER-system, sleeve-bearing version
Ecrous de serrage à palier lisse pour pinces DIN 6499 (ISO 15488) système ER



Verwendung:

Alle Spannzangen mit Außenform DIN 6499 (ISO 15488) können gespannt werden.

Application:

All collets with outside form DIN 6499 (ISO 15488) can be clamped.

Application:

Toutes les pinces avec une forme extérieure suivant DIN 6499 (ISO 15488) peuvent être serrées.

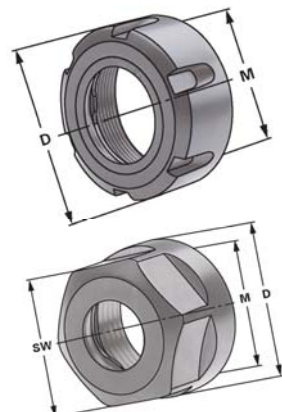

Bestell-Nr. Order no. Référence	Spannbereich Capacity Capacité	D	sw	M
112.02.10	1 – 10 (ER 16)	28	25	M22 × 1,5
112.02.16	2 – 16 (ER 25)	42		M32 × 1,5
112.02.20	2 – 20 (ER 32)	50		M40 × 1,5
112.02.26	3 – 26 (ER 40)	63		M50 × 1,5



Spannmuttern DIN 6388 (ISO 10897) System OZ, für Dichtscheiben

Clamping nuts DIN 6388 D (ISO 10897) OZ-system, for sealing discs

Ecrous de serrage DIN 6388 D (ISO 10897) système OZ, pour joints



Verwendung:

Zur Abdichtung von Werkzeugen mit Innenkühlung in Spannfutter DIN 6391, System OZ.

Application:

For sealing tools with internal cooling in collet chucks DIN 6391, OZ-system.

Application:

Pour assurer l'étanchéité en cas d'utilisation d'outils avec lubrification interne dans mandrins à pinces DIN6391, système OZ.

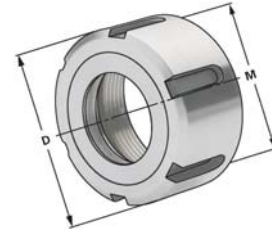

INFO ➔ 10.03

Bestell-Nr. Order no. Référence	Spannbereich Capacity Capacité	D	M
113.01.16	2 – 16 (OZ 16)	43	M33 × 1,5
113.01.25	2 – 25 (OZ 25)	60	M48 × 2
113.01.32	3 – 32 (OZ 32)	72	M60 × 2,5

Hinweis: Dichtscheiben sind getrennt zu bestellen.

Note: Sealing discs be ordered separately.

Observation: Joints doivent être commandés séparément.



Dichtscheiben für Spannmuttern System OZ

Sealing discs for clamping nuts OZ-system

Joints pour écrous de serrage système OZ



Verwendung:

Zur Abdichtung von Werkzeugen mit Innenkühlung.

Application:

For sealing tools with internal cooling.

Application:

Pour assurer l'étanchéité en cas d'utilisation d'outils avec lubrification interne.

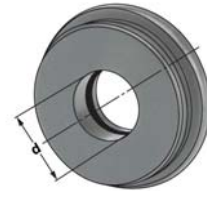

INFO ➔ 10.03

Bestell-Nr. Order no. Référence	Spannbereich Capacity Capacité	d*
01.16.xxx	2 – 16 (OZ 16)	2 – 16
01.25.xxx	2 – 25 (OZ 25)	2 – 25
01.32.xxx	3 – 32 (OZ 32)	3 – 32

d* Ø des Werkzeugs

Spannüberbrückung 0,5 mm (+0,1/–0,4)

d* Ø of the tool

Clamping range 0.5 mm (+0.1/–0.4)

d* Ø d'outil

Plage de serrage de 0,5 mm (+0,1/–0,4)

Hinweis: Dicht bis 80 bar Druck

Note: Sealing capacity up to 80 bar

Observation: Étanche jusqu'à la pression de 80 bar





Spannmuttern DIN 6499 (ISO 15488) System ER, für Dichtscheiben

Clamping nuts DIN 6499 (ISO 15488) ER-system, for sealing discs

Ecrous de serrage DIN 6499 (ISO 15488) système ER, pour joints



Verwendung:

Zur Abdichtung von Werkzeugen mit Innenkühlung in Spannfutter, System ER.

Application:

For sealing tools with internal cooling in collet chucks, ER-system.

Application:

Pour assurer l'étanchéité en cas d'utilisation d'outils avec lubrification interne dans mandrins à pinces, système ER.

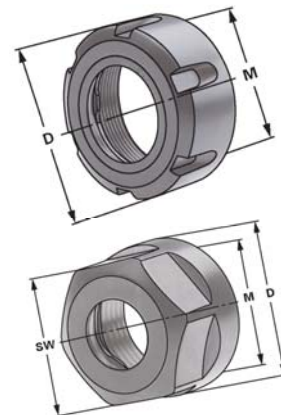

Bestell-Nr. Order no. Référence	Spannbereich Capacity Capacité	D	sw	M
113.02.10*	1 – 10 (ER 16)	28	25	M22 × 1,5
113.02.16	2 – 16 (ER 25)	42		M32 × 1,5
113.02.20	2 – 20 (ER 32)	50		M40 × 1,5
113.02.26	3 – 26 (ER 40)	63		M50 × 1,5

* Sechskantmutter

* Hexagonal clamping nut

* Écrou hexagonal

Hinweis: Dichtscheiben sind getrennt zu bestellen.

Note: Sealing discs be ordered separately.

Observation: Joints doivent être commandés séparément.



Dichtscheiben für Spannmuttern System ER

Sealing discs for clamping nuts ER-system

Joints pour écrous de serrage système ER



Verwendung:

Zur Abdichtung von Werkzeugen mit Innenkühlung.

Application:

For sealing tools with internal cooling.

Application:

Pour assurer l'étanchéité en cas d'utilisation d'outils avec lubrification interne.

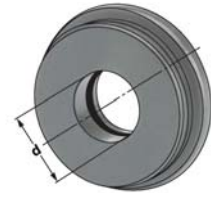

INFO ➔ 10.03

Bestell-Nr. Order no. Référence	Spannbereich Capacity Capacité	d*
02.10.xxx	1 – 10 (ER 16)	1,0 – 10,0
02.16.xxx	2 – 16 (ER 25)	1,0 – 16,0
02.20.xxx	2 – 20 (ER 32)	1,0 – 20,0
02.26.xxx	3 – 26 (ER 40)	2,0 – 26,0

d* Ø des Werkzeugs

Spannüberbrückung 0,5 mm (+0,1/–0,4)

d Ø of the tool*

Clamping range 0.5 mm (+0.1/–0.4)

d Ø d'outil*

Plage de serrage de 0,5 mm (+0,1/–0,4)

Hinweis: Dicht bis 80 bar Druck

Note: Sealing capacity up to 80 bar

Observation: Étanche jusqu'à la pression de 80 bar





Drehmomentschlüssel

Universal Torque Wrenches

Clés dynamométriques



Verwendung:

Zur Übertragung eines definierten Anzugsmomentes.

Application:

For the transfer of a defined torque.

Application:

Pour la transmission d'un couple de serrage défini.

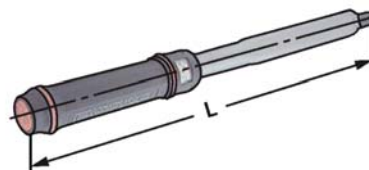

Bestell-Nr. Order no. Référence	Drehmoment Torque Couple	L
800.030	60 – 300 Nm	580

Schlüsseleinsätze für Spannmuttern System ER, mit Sechskant

Wrench inserts for clamping nuts ER-system, with hexagon

Inserts pour clés dynamométriques pour écrous de serrage système ER, avec hexagone



Verwendung:

Zur Übertragung eines definierten Anzugsmomentes.

Application:

For the transfer of a defined torque.

Application:

Pour la transmission d'un couple de serrage défini.

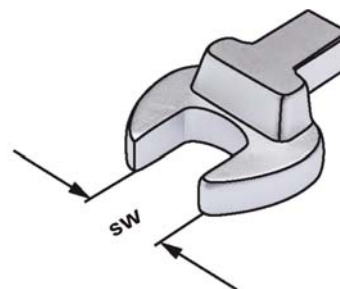

Bestell-Nr. Order no. Référence	Abmessung Size Dimension	SW
800.02.10	1 – 10 (ER 16)	25
800.02.10.2	1 – 10 (ER 16)	27

Schlüsseleinsätze für Spannmuttern System OZ

Wrench inserts for clamping nuts OZ-system

Inserts pour clés dynamométriques pour écrous de serrage système OZ



Verwendung:

Zur Übertragung eines definierten Anzugsmomentes.

Application:

For the transfer of a defined torque.

Application:

Pour la transmission d'un couple de serrage défini.

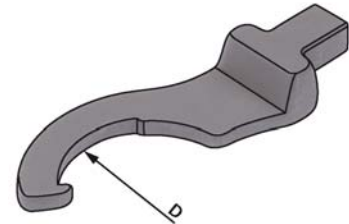

Bestell-Nr. Order no. Référence	Abmessung Size Dimension	D
800.01.16	2 – 16 (OZ 16)	40
800.01.25	2 – 25 (OZ 25)	58
800.01.32	3 – 32 (OZ 32)	68

Schlüsseleinsätze für Spannmuttern System ER

Wrench inserts for clamping nuts ER-system

Inserts pour clés dynamométriques pour écrous de serrage système ER



Verwendung:

Zur Übertragung eines definierten Anzugsmomentes.

Application:

For the transfer of a defined torque.

Application:

Pour la transmission d'un couple de serrage défini.

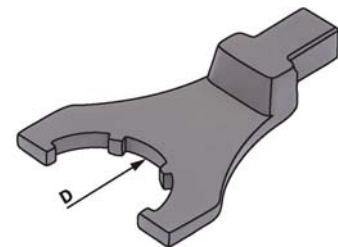

Bestell-Nr. Order no. Référence	Abmessung Size Dimension	D
800.02.10.1	1 – 10 (ER 16)	32
800.02.16	2 – 16 (ER 25)	42
800.02.20	2 – 20 (ER 32)	50
800.02.26	2 – 26 (ER 40)	63



Schlüsseleinsätze für Anzugsbolzen

Wrench inserts for Pull studs

Inserts pour tirettes



Verwendung:

Zur Übertragung eines definierten Anzugsmomentes.

Application:

For the transfer of a defined torque.

Application:

Pour la transmission d'un couple de serrage défini.

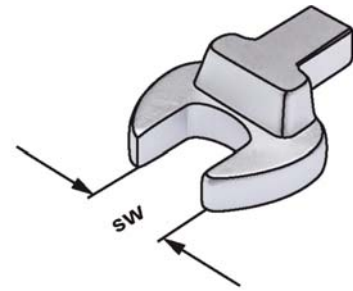

Bestell-Nr. Order no. Référence	Abmessung Size Dimension	SW
800.20.13	BT 30	13
800.20.14	SK 30	14
800.20.19	SK / BT 40	19
800.20.30	SK / BT 50	30

Hakenschlüssel DIN 1810 A für Spannmutter System OZ

Wrenches DIN 1810 A for clamping nuts OZ-system

Clés à ergot DIN 1810 A pour écrous de serrage système OZ



Verwendung:
Für Spannmutter System OZ.

Application:
For clamping nuts OZ-system.

Application:
Pour écrous de serrage système OZ.

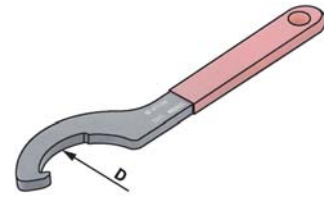

Bestell-Nr. Order no. Référence	Abmessung Size Dimension	D
01.16	2 – 16 (OZ 16)	40
01.25	2 – 25 (OZ 25)	58
01.32	3 – 32 (OZ 32)	68

Spannschlüssel für Spannmutter System ER

Wrenches for clamping nuts ER-system

Clés de serrage pour écrous de serrage système ER



Verwendung:
Für Spannmutter System ER.

Application:
For clamping nuts ER-system.

Application:
Pour écrous de serrage système ER.

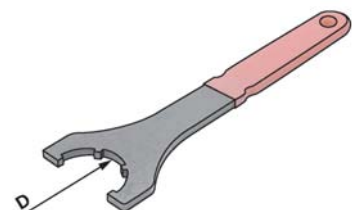

Bestell-Nr. Order no. Référence	Abmessung Size Dimension	D	sw
02.10 *	1 – 10 (ER 16)	28	25
02.10.1	1 – 10 (ER 16)	32	
02.10.2	1 – 10 (ER 16)	30	27
02.16	2 – 16 (ER 25)	42	
02.20	2 – 20 (ER 32)	50	
02.26	2 – 26 (ER 40)	63	

* Für Sechskantmutter

* For hexagonal clamping nut

* Pour écrou hexagonal



Anzugsbolzen DIN 69872 A+B

Pull studs DIN 69872 A+B

Tirettes DIN 69872 A+B

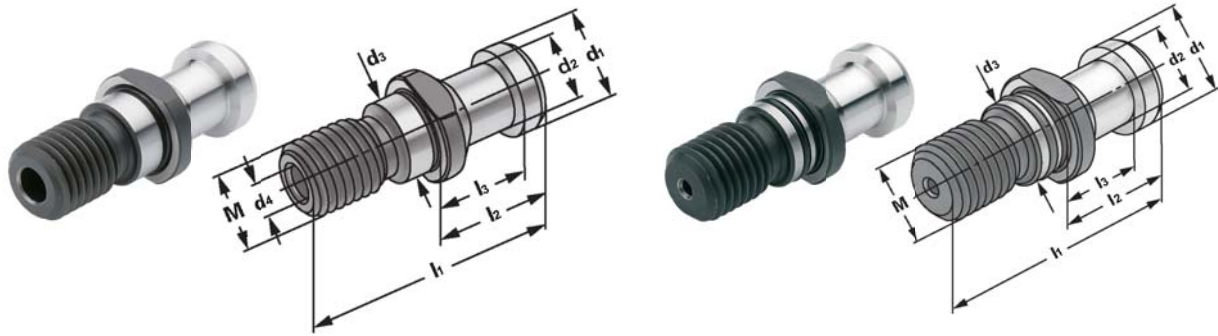

Form A
Form A
Forme A

Form B
Form B
Forme B

Bestell-Nr. Order no. Référence	M	l ₁	l ₂	l ₃	d ₁	d ₂	d ₃	d ₄
302.20.12	M12	44	24	19	13	9	13	3,0
402.20.16	M16	54	26	20	19	14	17	7,0
502.20.24	M24	74	34	25	28	21	25	11,5

Form A (mit Durchgangsbohrung, ohne O-Ring) DIN 69872 A

Form A (with drill through, without O-ring) DIN 69872 A

Forme A (percée, sans joint torique) DIN 69872 A

402.20.16.0	M16	54	26	20	19	14	17	7,0
502.20.24.0	M24	74	34	25	28	21	25	11,5

Form A (mit Durchgangsbohrung, inkl. O-Ring) DIN 69872 A

Form A (with drill through, incl. O-ring) DIN 69872 A

Forme A (percée, avec joint torique) DIN 69872 A

403.20.16	M16	54	26	20	19	14	17	–
503.20.24	M24	74	34	25	28	21	25	–

Form B (ohne Durchgangsbohrung, inkl. O-Ring) DIN 69872 B

Form B (sealed, incl. O-ring) DIN 69872 B

Forme B (étanche, avec joint torique) DIN 69872 B

7

Anzugsbolzen ähnlich DIN 69872 A, um 3 mm verlängert

Pull studs similar to DIN 69872 A, lengthened by 3 mm

Tirettes ressemblant à DIN 69872 A, allongé par 3 mm

Bestell-Nr. Order no. Référence	M	l ₁	l ₂	l ₃	d ₁	d ₂	d ₃	d ₄
402.20.16.21	M16	54	29	23	19	14	17	7,0

Form A (mit Durchgangsbohrung, inkl. O-Ring)

Form A (with drill through, incl. O-ring)

Forme A (percée, avec joint torique)

7.40

Anzugsbolzen ISO 7388

Pull studs ISO 7388

Tirettes ISO 7388



Form B
Form B
Forme B

Bestell-Nr. Order no. Référence	M	l_1	l_2	l_3	d_1	d_2	d_3	d_4
404.20.16	M16	44,5	16,40	11,15	18,95	12,95	17	7,0
504.20.24	M24	65,5	25,55	17,95	29,10	19,60	25	11,5

Form II B (mit Durchgangsbohrung, ohne O-Ring)

Form II B (with drill through, without O-ring)

Forme II B (percée, sans joint torique)

404.20.16.0	M16	44,5	16,40	11,15	18,95	12,95	17	7,0
504.20.24.0	M24	65,5	25,55	17,95	29,10	19,60	25	11,5

Form II B (mit Durchgangsbohrung, inkl. O-Ring)

Form II B (with drill through, incl. O-ring)

Forme II B (percée, avec joint torique)

404.20.16.30	M16	44,5	16,40	11,15	18,95	12,95	17	–
--------------	-----	------	-------	-------	-------	-------	----	---

Form 7388 (ohne Durchgangsbohrung, inkl. O-Ring)

Form 7388 (sealed, incl. O-ring)

Forme 7388 (étanche, avec joint torique)

Anzugsbolzen ähnlich ISO 7388, um 3 mm verlängert

Pull studs similar to ISO 7388, lengthened by 3 mm

Tirettes ressemblant à ISO 7388, allongé par 3 mm

Bestell-Nr. Order no. Référence	M	l_1	l_2	l_3	d_1	d_2	d_3	d_4
404.20.16.20	M16	47,50	19,25	14,15	18,95	12,95	17,00	7,3

Mit Durchgangsbohrung, inkl. O-Ring

With drill through, incl. O-ring

Percée, avec joint torique



Anzugsbolzen CAT metrisch

Pull studs CAT metric

Tirettes CAT métrique

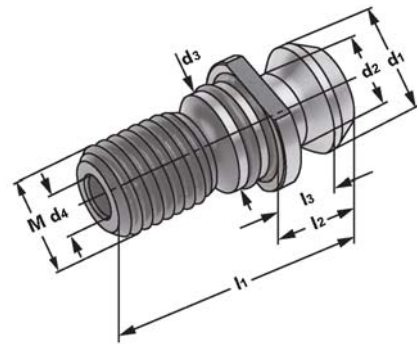

Bestell-Nr.

Order no.

Référence

	M	l ₁	l ₂	l ₃	d ₁	d ₂	d ₃	d ₄
404.20.16.21	M16	41,26	16,26	11,18	18,80	12,45	17,00	7,0

Mit Durchgangsbohrung, inkl. O-Ring

With drill through, incl. O-ring

Percée, avec joint torique

504.20.24.21	M24	65,40	25,40	17,80	28,95	20,80	25,00	11,5
--------------	-----	-------	-------	-------	-------	-------	-------	------

SK 50 mit Freidrehung im Kopf für O-Ring

SK 50 with open head rotation for O-rings

SK 50 avec rotation libre du tête pour joints ronds

Anzugsbolzen CAT metrisch für Hochdruckkühlung

Pull studs CAT metric for high-pressure cooling

Tirettes CAT métrique pour refroidissement sous haute pression

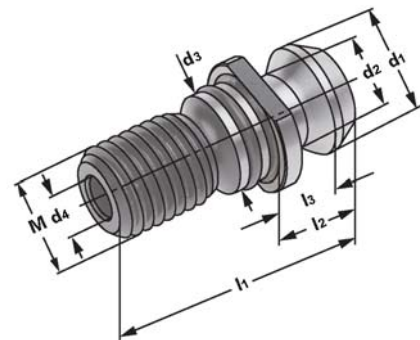

Bestell-Nr.

Order no.

Référence

	M	l ₁	l ₂	l ₃	d ₁	d ₂	d ₃	d ₄
404.20.16.22	M16	41,26	16,26	11,18	18,80	12,45	17,00	7,0

504.20.24.22	M24	65,40	25,40	17,80	28,95	20,80	25,00	11,5
--------------	-----	-------	-------	-------	-------	-------	-------	------

Mit Durchgangsbohrung, inkl. O-Ringen in der Bohrung und am Bund

With drill through, incl. O-rings in the bore and the collar

Percée, avec joints toriques dans le trou et la collerette

Anzugsbolzen MAS 403 BT (JIS B 6339)

Pull studs MAS 403 BT (JIS B 6339)

Tirettes MAS 403 BT (JIS B 6339)

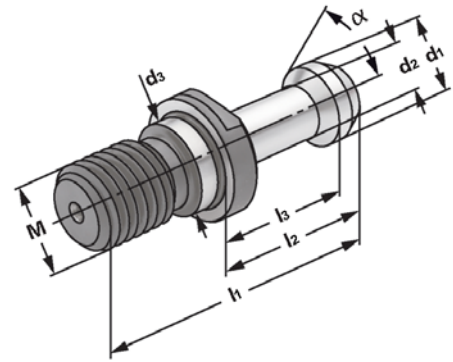

Bestell-Nr. Order no. Référence	M	α	l_1	l_2	l_3	d_1	d_2	d_3	d_4
305.20.45	M12	45°	43	23	18	11	7	12,5	–
305.20.60	M12	60°	43	23	18	11	7	12,5	–
405.20.45	M16	45°	60	35	28	15	10	17,0	–
405.20.60	M16	60°	60	35	28	15	10	17,0	–
405.20.90	M16	90°	60	35	28	15	10	17,0	–
505.20.45	M24	45°	85	45	35	23	17	25,0	–
505.20.60	M24	60°	85	45	35	23	17	25,0	–
505.20.90	M24	90°	85	45	35	23	17	25,0	–

Ohne Durchgangsbohrung, ohne O-Ring

Sealed, without O-ring

Étanche, sans joint torique

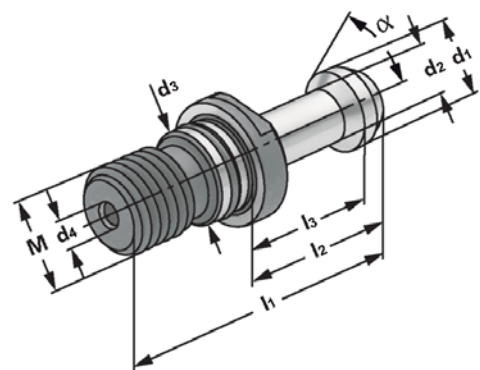

406.20.45	M16	45°	60	35	28	15	10	17,0	4,0
406.20.60	M16	60°	60	35	28	15	10	17,0	4,0
406.20.90	M16	90°	60	35	28	15	10	17,0	4,0
506.20.45	M24	45°	85	45	35	23	17	25,0	6,0
506.20.60	M24	60°	85	45	35	23	17	25,0	6,0
506.20.90	M24	90°	85	45	35	23	17	25,0	6,0

Mit Durchgangsbohrung, inkl. O-Ring

With drill through, incl. O-ring

Percée, avec joint torique



Анзугболзены ахныч MAS 403 BT (JIS B 6399), ум 3 мм веркързт

Pull studs similar to MAS 403 BT (JIS B 6399), shortened by 3 mm

Tirettes ressemblant à MAS 403 BT (JIS B 6399), raccourci par 3 mm

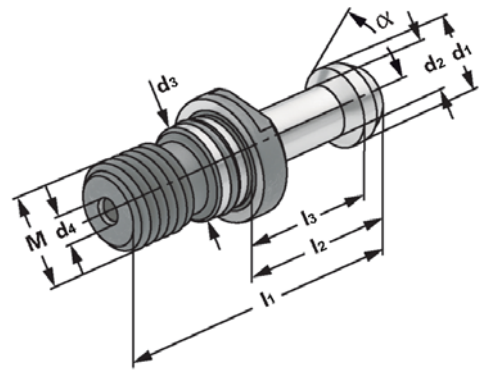

Bestell-Nr. Order no. Référence	M	α	l_1	l_2	l_3	d_1	d_2	d_3	d_4
405.20.45.21	M16	45°	57	32	25	15	10	17	4,0
405.20.60.21	M16	60°	57	32	25	15	10	17	4,0
405.20.90.21	M16	90°	57	32	25	15	10	17	4,0

Mit Durchgangsbohrung, inkl. O-Ring

With drill through, incl. O-ring

Percée, avec joint torique

406.20.45.21	M16	45°	57	32	25	15	10	17	–
406.20.60.21	M16	60°	57	32	25	15	10	17	–
406.20.90.21	M16	90°	57	32	25	15	10	17	–

Ohne Durchgangsbohrung, inkl. O-Ring

Sealed, incl. O-ring

Étanche, avec joint torique

Anzugsbolzen DIN 2080 mit Ott-Ringnut

Pull studs DIN 2080 with Ott-groove

Tirettes DIN 2080 avec gorte Ott

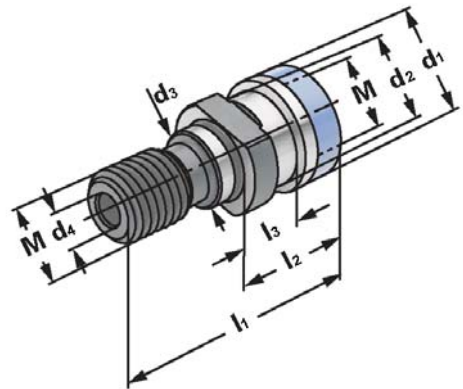

Bestell-Nr. Order no. Référence	M	l ₁	l ₂	l ₃	d ₁	d ₂	d ₃	d ₄
401.20.16	M16	53,0	25,1	13,6	25,00	21,1	17	7,0
501.20.24	M24	65,1	25,1	13,3	39,60	32,0	25	7,0

Mit Innengewinde und Durchgangsbohrung

With internal thread and drill through

Avec filetage intérieur et perçage

Hinweis: Mit Kantenschutzring
Note: With protection ring
Observation: Avec bague de protection

Anzugsbolzen S 20 × 2

Pull studs S 20 × 2

Tirettes S 20 × 2

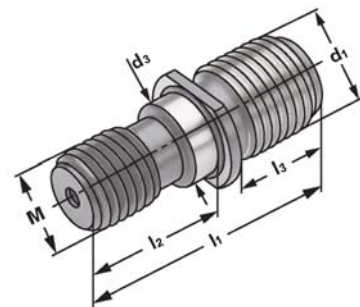

Bestell-Nr. Order no. Référence	M	l ₁	l ₂	l ₃	d ₁	d ₃
401.20.16.S	M16	56,0	28,0	19,0	S 20 × 2	17,0



Schnellwechsel-Einsätze ohne Sicherheitskupplung, Größe 1

Quick change adaptors without safety clutch, size 1

Adaptateurs à changement rapide sans limiteur de couple, taille 1



Verwendung:

Zur Spannung von Gewindebohrern.
Für Rechts- und Linksgewinde. Standardausführung ohne Sicherheitskupplung.

Application:

For mounting taps. For right-hand and left-hand threads. Standard type without safety clutch.

Application:

Pour le serrage de tarauds. Pour taraudage à droite et à gauche. Modèle standard sans limiteur de couple.

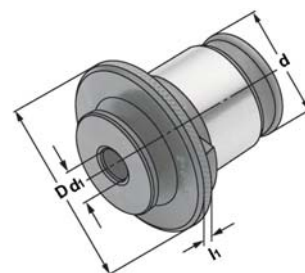

Bestell-Nr. Order no. Référence	D	d	l ₁	Schaft Shaft Queue d ₁	Vierkant Square Carré
16.01.3527	30	19	5	3,5	2,7
16.01.4534	30	19	5	4,5	3,4
16.01.43	30	19	5	4,0	3,0
16.01.649	30	19	5	6,0	4,9
16.01.755	30	19	5	7,0	5,5
16.01.862	30	19	5	8,0	6,2
16.01.97	30	19	5	9,0	7,0
16.01.108	30	19	5	10,0	8,0
16.01.119	30	19	5	11,0	9,0

Hinweis: Bei Adaptern ohne Sicherheitskupplung ist ein Austausch möglich, da nur Werkzeugschaft-Ø und Vierkant passend sein müssen.

Note: Quick change adaptors without safety clutch can be interchanged, because only the shaft diameters and the squares must fit.

Observation: On peut substituer les adaptateurs sans limiteur de couple, parce que seulement la queue et le carré doivent repérer.

Schnellwechsel-Einsätze mit Sicherheitskupplung, Größe 1

Quick change adaptors with safety clutch, size 1

Adaptateurs à changement rapide avec limiteur de couple, taille 1



Verwendung:

Zur Spannung von Gewindebohrern.
Für Rechts- und Linksgewinde. Ausführung mit einstellbarer Sicherheitskupplung zur Vermeidung von Gewindebohrerbruch.

Application:

For mounting taps. For right-hand and left-hand threads. Type with adjustable safety clutch, which prevents the breaking of taps.

Application:

Pour le serrage de tarauds. Pour taraudage à droite et à gauche. Modèle avec limiteur de couple, qui prévient la casse des tarauds.

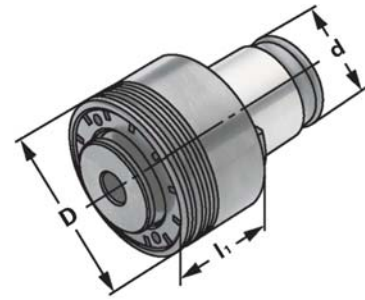

Bestell-Nr. Order no. Référence	D	d	l ₁	M	DIN	Schaft Shaft Queue d ₁	Vierkant Square Carré
16.11.335	32	19	25	M3	371	3,5	2,7
16.11.354	32	19	25	M3,5	371	4,0	3,0
16.11.445	32	19	25	M4	371	4,5	3,4
16.11.5649	32	19	25	M5	371	6,0	4,9
16.11.6649	32	19	25	M6	371	6,0	4,9
16.11.88	32	19	25	M8	371	8,0	6,2
16.11.107	32	19	25	M10	376	7,0	5,5
16.11.1010	32	19	25	M10	371	10,0	8,0
16.11.129	32	19	25	M12	376	9,0	7,0
16.11.14119	32	19	25	M14	376	11,0	9,0

Hinweis: Bei Adaptern mit Sicherheitskupplung wird das Drehmoment entsprechend der Gewindegröße vor Auslieferung eingestellt.

Note: Quick change adaptors with safety clutch are supplied with a predefined torque, corresponding to the sizes of the threads.

Observation: Les adaptateurs porte-tarauds à changement rapide avec limiteur de couple sont fournis avec un couple pré-régulé, qui correspond aux tailles de filetages.



Schnellwechsel-Einsätze ohne Sicherheitskupplung, Größe 2

Quick change adaptors without safety clutch, size 2

Adaptateurs à changement rapide sans limiteur de couple, taille 2



Verwendung:

Zur Spannung von Gewindebohrern.
Für Rechts- und Linksgewinde. Standardausführung ohne Sicherheitskupplung.

Application:

For mounting taps. For right-hand and left-hand threads. Standard type without safety clutch.

Application:

Pour le serrage de tarauds. Pour taraudage à droite et à gauche. Modèle standard sans limiteur de couple.

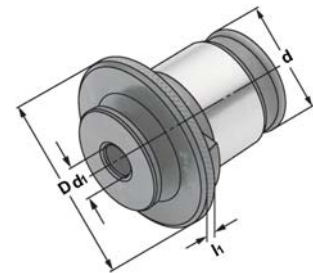

Bestell-Nr. Order no. Référence	D	d	l ₁	Schaft Shaft Queue d ₁	Vierkant Square Carré
16.02.649	48	31	6	6	4,9
16.02.755	48	31	6	7	5,5
16.02.862	48	31	6	8	6,2
16.02.97	48	31	6	9	7,0
16.02.108	48	31	6	10	8,0
16.02.119	48	31	6	11	9,0
16.02.129	48	31	6	12	9,0
16.02.1411	48	31	6	14	11,0
16.02.1612	48	31	6	16	12,0
16.02.18145	48	31	6	18	14,5

Hinweis: Bei Adaptern ohne Sicherheitskupplung ist ein Austausch möglich, da nur Werkzeugschaft-Ø und Vierkant passend sein müssen.

Note: Quick change adaptors without safety clutch can be interchanged, because only the shaft diameters and the squares must fit.

Observation: On peut substituer les adaptateurs sans limiteur de couple, parce que seulement la queue et le carré doivent repérer.

Schnellwechsel-Einsätze mit Sicherheitskupplung, Größe 2

Quick change adaptors with safety clutch, size 2

Adaptateurs à changement rapide avec limiteur de couple, taille 2



Verwendung:

Zur Spannung von Gewindebohrern.
Für Rechts- und Linksgewinde. Ausführung mit einstellbarer Sicherheitskupplung zur Vermeidung von Gewindebohrerbruch.

Application:

For mounting taps. For right-hand and left-hand threads. Type with adjustable safety clutch, which prevents the breaking of taps.

Application:

Pour le serrage de tarauds. Pour taraudage à droite et à gauche. Modèle avec limiteur de couple, qui prévient la casse des tarauds.

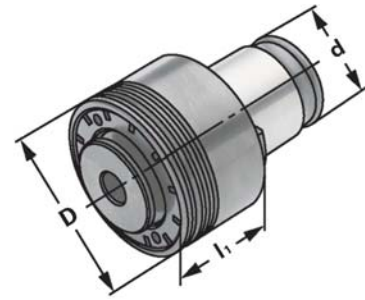

Bestell-Nr. Order no. Référence	D	d	l ₁	M	DIN	Schaft Shaft Queue d ₁	Vierkant Square Carré
16.12.5649	50	31	31	M5	371	6	4,9
16.12.6649	50	31	31	M6	371	6	4,9
16.12.88	50	31	31	M8	371	8	6,2
16.12.107	50	31	31	M10	376	7	5,5
16.12.1010	50	31	31	M10	371	10	8,0
16.12.129	50	31	31	M12	376	9	7,0
16.12.1411	50	31	31	M14	376	11	9,0
16.12.1612	50	31	31	M16	376	12	9,0
16.12.181411	50	31	31	M18	376	14	11,0
16.12.2016	50	31	31	M20	376	16	12,0
16.12.2218145	50	31	31	M22	376	18	14,5

Hinweis: Bei Adaptern mit Sicherheitskupplung wird das Drehmoment entsprechend der Gewindegröße vor Auslieferung eingestellt.

Note: Quick change adaptors with safety clutch are supplied with a predefined torque, corresponding to the sizes of the threads.

Observation: Les adaptateurs porte-tarauds à changement rapide avec limiteur de couple sont fournis avec un couple pré-réglé, qui correspond aux tailles de filetages.



Schnellwechsel-Einsätze ohne Sicherheitskupplung, Größe 3

Quick change adaptors without safety clutch, size 3

Adaptateurs à changement rapide sans limiteur de couple, taille 3



Verwendung:

Zur Spannung von Gewindebohrern.
Für Rechts- und Linksgewinde. Standardausführung ohne Sicherheitskupplung.

Application:

For mounting taps. For right-hand and left-hand threads. Standard type without safety clutch.

Application:

Pour le serrage de tarauds. Pour taraudage à droite et à gauche. Modèle standard sans limiteur de couple.

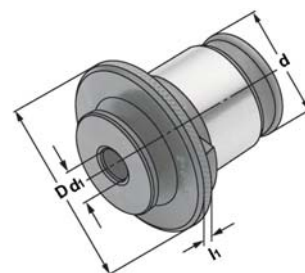

Bestell-Nr. Order no. Référence	D	d	l ₁	Schaft Shaft Queue d ₁	Vierkant Square Carré
16.03.119	63	48	6	11	9,0
16.03.129	63	48	6	12	9,0
16.03.1411	63	48	6	14	11,0
16.03.1612	63	48	6	16	12,0
16.03.18145	63	48	6	18	14,5
16.03.2016	63	48	6	20	16,0
16.03.2218	63	48	6	22	18,0
16.03.2520	63	48	6	25	20,0
16.03.2822	63	48	6	28	22,0

Hinweis: Bei Adaptern ohne Sicherheitskupplung ist ein Austausch möglich, da nur Werkzeugschaft-Ø und Vierkant passend sein müssen.

Note: Quick change adaptors without safety clutch can be interchanged, because only the shaft diameters and the squares must fit.

Observation: On peut substituer les adaptateurs sans limiteur de couple, parce que seulement la queue et le carré doivent repérer.

Schnellwechsel-Einsätze mit Sicherheitskupplung, Größe 3

Quick change adaptors with safety clutch, size 3

Adaptateurs à changement rapide avec limiteur de couple, taille 3



Verwendung:

Zur Spannung von Gewindebohrern.
Für Rechts- und Linksgewinde. Ausführung mit einstellbarer Sicherheitskupplung zur Vermeidung von Gewindebohrerbruch.

Application:

For mounting taps. For right-hand and left-hand threads. Type with adjustable safety clutch, which prevents the breaking of taps.

Application:

Pour le serrage de tarauds. Pour taraudage à droite et à gauche. Modèle avec limiteur de couple, qui prévient la casse des tarauds.

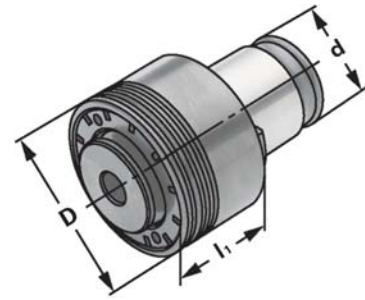

Bestell-Nr. Order no. Référence	D	d	l ₁	M	DIN	Schaft Shaft Queue d ₁	Vierkant Square Carré
16.13.14119	72	48	41	M14	376	11	9,0
16.13.16129	72	48	41	M16	376	12	9,0
16.13.181411	72	48	41	M18	376	14	11,0
16.13.201612	72	48	41	M20	376	16	12,0
16.13.2218145	72	48	41	M22	376	18	14,5
16.13.2418145	72	48	41	M24	376	18	14,5
16.13.272016	72	48	41	M27	376	20	16,0
16.13.302218	72	48	41	M30	376	22	18,0
16.13.332522	72	48	41	M33	376	25	20,0
16.13.362822	72	48	41	M36	376	28	22,0

Hinweis: Bei Adaptern mit Sicherheitskupplung wird das Drehmoment entsprechend der Gewindegröße vor Auslieferung eingestellt.

Note: Quick change adaptors with safety clutch are supplied with a predefined torque, corresponding to the sizes of the threads.

Observation: Les adaptateurs porte-tarauds à changement rapide avec limiteur de couple sont fournis avec un couple pré-régulé, qui correspond aux tailles de filetages.



Reduzieradapter für Schnellwechsel-Einsätze

Reducing adaptors for quick change adaptors

Réductions pour adaptateurs à changement rapide



Verwendung:

Reduzieradapter zum Reduzieren der Größen 3 auf 2 bzw. 2 auf 1. Hiermit können die Spannbereiche nach unten erweitert werden.

Application:

Reducing adaptor for reducing size 3 to 2 and 2 to 1. In this way the clamping ranges can be extended to smaller sizes.

Application:

Pour la réduction des tailles 3 à 2 et 2 à 1. Il est ainsi possible d'élargir la plage inférieure de serrage.

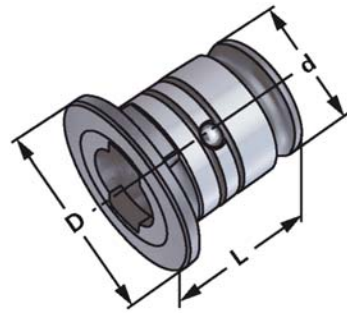

Bestell-Nr. Order no. Référence	Aufnahme workholder logement	Einsatz adaptor adapt.	D	d	L
16.00.0201	2	1	48	31	40,4
16.00.0302	3	2	59	48	62,6

Gewindebohrer-Schaftmaße*Screw taps-shaft size*

Pour taraud-taille de la tige



Schaftmaße Ø × □ Shaft diameter Ø × □ Diamètre de la queue Ø × □	DIN 352	DIN 5157	DIN 371	DIN 374	DIN 376
Ø 2,5 × 2,1 □	M1		M1	M3	M3,5
Ø 2,5 × 2,1 □	M1,1		M1,1	M3,5	
Ø 2,5 × 2,1 □	M1,2		M1,2		
Ø 2,5 × 2,1 □	M1,4		M1,4		
Ø 2,5 × 2,1 □	M1,6		M1,6		
Ø 2,5 × 2,1 □	M1,8		M1,8		
Ø 2,8 × 2,1 □	M2		M2	M4	M4
Ø 2,8 × 2,1 □	M2,2		M2,2		
Ø 2,8 × 2,1 □	M2,5		M2,5		
Ø 3,5 × 2,7 □	M3		M3	M5	M5
Ø 4 × 3 □	M3,5		M3,5		
Ø 4,5 × 3,4 □	M4		M4	M6	M6
Ø 6 × 4,9 □	M5		M5		
Ø 6 × 4,9 □	M6		M6		
Ø 6 × 4,9 □	M8			M8	M8
Ø 7 × 5,5 □	M10	G 1/8"		M10	M10
Ø 8 × 6,2 □			M8		
Ø 9 × 7 □	M12			M12	M12
Ø 10 × 8 □			M10		
Ø 11 × 9 □	M14	G 1/4"		M14	M14
Ø 12 × 9 □	M16	G 3/8"		M16	M16
Ø 14 × 11 □	M18			M18	M18
Ø 16 × 12 □	M20	G 1/2"		M20	M20
Ø 18 × 14,5 □	M22	G 5/8"		M22	M22
Ø 18 × 14,5 □	M24			M24	M24
Ø 20 × 16 □	M27	G 3/4"		M27	M27
Ø 22 × 18 □	M30	G 7/8"		M30	M30
Ø 25 × 20 □	M33	G 1		M33	M33
Ø 28 × 22 □	M36	G 1 1/8"		M36	M36
Ø 32 × 34 □	M39	G 1 1/4"		M39	M39
Ø 32 × 24 □	M42			M42	M42
Ø 36 × 29 □	M45	G 1 3/8"		M45	M45
Ø 36 × 29 □	M48	G 1 1/2"		M48	M48
Ø 36 × 29 □		G 1 3/4"			
Ø 36 × 29 □		G 2"			



Gewindeschneid-Schnellwechselfutter mit Längenausgleich auf Druck und Zug für Zylinderschäfte DIN 1835 B+E

Quick change tapping chucks with length compensation on compression and expansion for tool shanks DIN 1835 B+E

Mandrins de taraudage à changement rapide avec compensation longitudinale à la compression et traction pour queues cylindriques DIN 1835 B+E



Verwendung:

Zur Aufnahme von Schnellwechsel-Einsätzen für Gewindebohrer.

Application:

For the chucking of Quick change taps for threading taps.

Application:

Pour le serrage d'adaptateurs porte-tarauds à changement rapide.

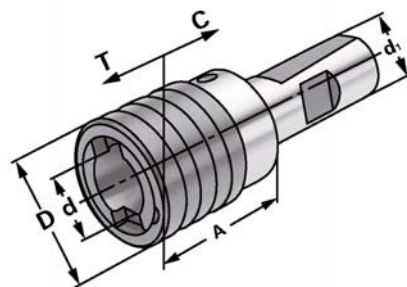

INFO ➔ 10.03

Bestell-Nr. Order no. Référence	d_1	Spannbereich Capacity Capacité	Größe Size Dimension	A	D	d	T	C
120.16.2012	20	M3 – M14	1	44	36	19	7	7
120.16.2020	20	M5 – M22	2	73	53	31	12	12

Hinweis: Für Bearbeitungszentren ohne Synchronspindel.

Note: On machining centres without synchronised spindles.

Observation: Sur centres d'usinage sans axe synchrone.

Ausführung: mit seitlicher Spannfläche nach DIN 1835 Form B (Weldon) und DIN 1835 Form E (Whistle Notch).

Version: with flat according to DIN 1835 form B (Weldon) and inclined flat according to DIN 1835 form E (Whistle Notch).

Version: avec queue cylindrique et avec méplat suivant DIN 1835 forme B (Weldon) et avec méplat incliné suivant DIN 1835 forme E (Whistle Notch).



Gewindeschneidfutter für Synchronisation mit Zylinderschaft DIN 1835 B+E für Spannzangen DIN 6499 (ISO 15488) System ER

Tapping chucks for synchronisation with tool shanks DIN 1835 B+E for collets DIN 6499 (ISO 15488) ER-system

Mandrins de taraudage pour synchronisation avec queues cylindriques DIN 1835 B+E pour pinces DIN 6499 (ISO 15488) système ER



Verwendung:
Für Bearbeitungszentren mit Synchronspindel.

Application:
For machining centres with synchronous spindle.

Application:
Pour centres d'usinage avec broche synchrone.

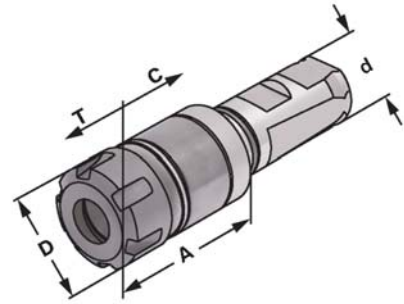

Bestell-Nr. Order no. Référence	d	Spannbereich Capacity Capacité	A	D	T	C
120.16.2516	25	M3 – M10 (ER 16)	60	32	0,5	0,5
120.16.2532	25	M4 – M27 (ER 32)	74	50	0,5	0,5

- Hinweis:**
- Synchro-Gewindeschneidfutter kompensieren Synchronisationsfehler.
 - Minimallängenausgleich in Druck- und Zugrichtung zwischen Synchronspindel und Gewindebohrer reduziert zu hohe Gewindeflankenreibungskräfte.
 - Reduziert eventuelle Axialkraftherhöhung während des Schneidzyklus auf ein Minimum.
 - Geeignet für Innenkühlung.
 - Kühlmitteldruck max. 100 bar.
- Note:**
- *Synchro tapping chucks compensate synchronisation errors.*
 - *Minimal length compensation on compression and expansion balances very small pitch differences between synchro spindle and tap, which can cause high frictional forces on the thread flanks.*
 - *A possible increase of axial force during the tapping process is reduced to a minimum.*
 - *Suitable for internal coolant.*
 - *Coolant pressure up to max. 100 bar.*
- Observation:**
- Mandrins de taraudage version „synchro“ compensent les erreurs éventuelles de synchronisation.
 - Compensation longitudinale minimale à la compression et traction entre la broche synchronisée et le taraud réduit la friction au niveau des flancs de filets.
 - Réduit au minimum les efforts éventuelles axiaux lors du cycle de taraudage.
 - Approprié pour la lubrification centrale.
 - Pression de lubrification max. 100 bar.

Lieferumfang: Mit gewuchteter Spannmutter

Delivery: With balanced clamping nut

Livraison: Avec écrou de serrage équilibré





Gewindebohrer-Spannhülsen für Fräseraufnahmen DIN 1835 B mit Schnellwechsel-Kupplung

Clamping sleeves for taps in end mill holders DIN 1835 B with quick change adaptor

Douilles de serrage à changement rapide pour tarauds dans des porte-fraises DIN 1835 B



Verwendung:

Für Maschinen mit steigungssynchronem Vorschub. Zur verdrehsicheren Spannung von Gewindebohrern in Fräseraufnahmen nach DIN 1835 B.

Application:

For machines with rigid tapping. For safe clamping of taps in end mill holders according to DIN 1835 B.

Application:

Pour machines avec broche synchronisée. Pour le serrage stable de tarauds dans des attachements porte-fraises suivant DIN 1835 B.

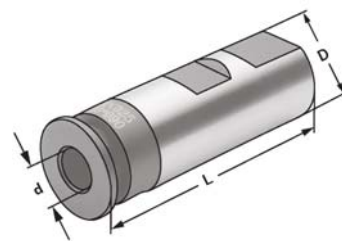

Bestell-Nr. Order no. Référence	D	Schaft Shaft Queue d	Vierkant Square Carré	L
16.16.3527	16	3,5	2,7	56,0
16.16.4030	16	4,0	3,0	56,0
16.16.4534	16	4,5	3,4	56,0
16.16.649	16	6,0	4,9	56,0
16.20.4534	20	4,5	3,4	58,0
16.20.649	20	6,0	4,9	58,0
16.20.755	20	7,0	5,5	58,0
16.20.862	20	8,0	6,2	58,0
16.20.97	20	9,0	7,0	58,0
16.20.108	20	10,0	8,0	58,0
16.25.4534	25	4,5	3,4	66,0
16.25.649	25	6,0	4,9	66,0
16.25.755	25	7,0	5,5	66,0
16.25.862	25	8,0	6,2	66,0
16.25.97	25	9,0	7,0	66,0
16.25.108	25	10,0	8,0	66,0
16.25.119	25	11,0	9,0	66,0
16.25.129	25	12,0	9,0	66,0
16.32.649	32	6,0	4,9	70,0
16.32.755	32	7,0	5,5	70,0
16.32.862	32	8,0	6,2	70,0
16.32.97	32	9,0	7,0	70,0
16.32.108	32	10,0	8,0	70,0
16.32.119	32	11,0	9,0	70,0
16.32.129	32	12,0	9,0	70,0
16.32.1411	32	14,0	11,0	70,0
16.32.1612	32	16,0	12,0	70,0
16.32.18145	32	18,0	14,5	70,0

Gewindebohrer-Spannhülsen für Fräseraufnahmen DIN 1835 B

Clamping sleeves for taps in end mill holders DIN 1835 B

Douilles de serrage pour tarauds dans des porte-fraises DIN 1835 B



Verwendung:

Für Maschinen mit steigungssynchronem Vorschub. Zur verkehrsicheren Spannung von Gewindebohrern in Fräseraufnahmen nach DIN 1835 B.

Application:

For machines with rigid tapping. For safe clamping of taps in end mill holders according to DIN 1835 B.

Application:

Pour machines avec broche synchronisée. Pour le serrage stable de tarauds dans des porte-fraises suivant DIN 1835 B.

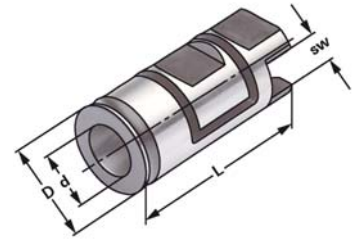

Bestell-Nr. Order no. Référence	D	Schaft Shaft Queue d	Vierkant Square Carré sw	L
704.04.0825	8	2,5	2,1	36
704.04.0828	8	2,8	2,1	36
704.04.1035	10	3,5	2,7	40
704.04.1040	10	4,0	3,0	40
704.04.1045	10	4,5	3,4	40
704.04.1260	12	6,0	4,9	45
704.04.1470	14	7,0	5,5	45
704.04.1480	14	8,0	6,2	48
704.04.1690	16	9,0	7,0	48
704.04.1610	16	10,0	8,0	48
704.04.1811	18	11,0	9,0	50
704.04.2012	20	12,0	9,0	50
704.04.2514	25	14,0	11,0	56
704.04.2516	25	16,0	12,0	56
704.04.3218	32	18,0	14,5	60
704.04.3220	32	20,0	16,0	60
704.04.3222	32	22,0	18,0	60



Fräseranzugschrauben DIN 6367

Retaining screws DIN 6367

Vis de serrage DIN 6367



Verwendung:

Fräseranzugsschraube zum Befestigen von Aufsteckfräsern.

Application:

Retaining screw for mounting of face mills arbors.

Application:

Vis de serrage pour la fixation de fraises.

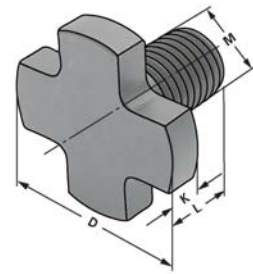

Bestell-Nr. Order no. Référence	Abmessung Size Dimension	M	D	K	L
102.10.16	16	M8	20	6	16
102.10.22	22	M10	28	7	18
102.10.27	27	M12	35	8	22
102.10.32	32	M16	42	9	26
102.10.40	40	M20	52	10	30
102.10.50	50	M24	63	12	36
102.10.60	60	M30	75	14	45



Fräseranzugschrauben DIN 6367 durchbohrt für Kühlmittelzufuhr

Retaining screws DIN 6367 with drill through for coolant

Vis de serrage DIN 6367 percée pour l'arrosage



Verwendung:

Fräseranzugsschraube zum Befestigen von Aufsteckfräsern.

Application:

Retaining screw for mounting of face mills arbors.

Application:

Vis de serrage pour la fixation de fraises.

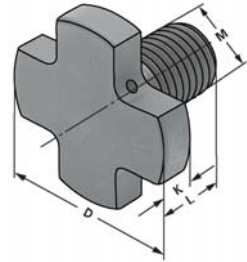

Bestell-Nr. Order no. Référence	Abmessung Size Dimension	M	D	K	L
102.11.16	16	M8	20	6	16
102.11.22	22	M10	28	7	18
102.11.27	27	M12	35	8	22
102.11.32	32	M16	42	9	26
102.11.40	40	M20	52	10	30
102.11.50	50	M24	63	12	36
102.11.60	60	M30	75	14	45





Spannschlüssel DIN 6368 für Aufsteckdorne

Wrenches DIN 6368 for shell arbors

Clés de serrage DIN 6368 pour broches creuses



Verwendung:
Für Fräseranzugsschraube DIN 6367.

Application:
For retaining screw DIN 6367.

Application:
Pour vis de fixation DIN 6367.

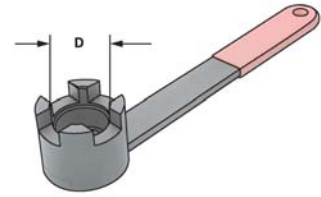

Bestell-Nr. Order no. Référence	D
10.16	16 / M8
10.22	22 / M10
10.27	27 / M12
10.32	32 / M16
10.40	40 / M20

Mitnehmerringe DIN 6366

Clutch drive rings DIN 6366

Bagues d'entraînement DIN 6366



Verwendung:
Für Kombi-Aufsteckfräserdorne DIN 6358.

Application:
For combi shell mill holders DIN 6358.

Application:
Pour porte-fraises à double usage DIN 6358.

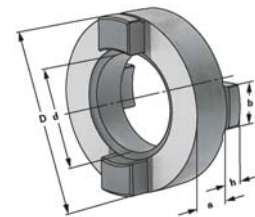

Bestell-Nr. Order no. Référence	d	D	a	b	h
101.10.16	16	32	10	8	5
101.10.22	22	40	12	10	5,6
101.10.27	27	46	12	12	6,3
101.10.32	32	55	14	14	7
101.10.40	40	68	14	16	8

Spannschrauben für Weldon Spannfutter DIN 1835 B

Clamping screws for Weldon chucks DIN 1835 B

Vis de serrage pour mandrins Weldon DIN 1835 B



Verwendung:

Für Fräseraufnahmen DIN 6359 für Zylinderschäfte DIN 1835-B

Application:

End mill holders DIN 6359 for Weldon type end mills DIN 1835-B

Application:

Porte-fraises DIN 6359 pour queues cylindriques Weldon DIN 1835-B

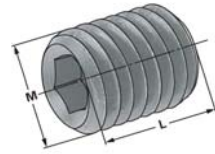

Bestell-Nr. Order no. Référence	M	L	für Durchmesser for diameter pour diamètre
101.04.06	M6	10	6
101.04.08	M8	10	8
101.04.10	M10	12	10
101.04.12	M12	16	12+14
101.04.16	M14	16	16+18
101.04.20	M16	16	20
101.04.25	M18 × 2	20	25
101.04.32	M20 × 2 × 20	20	32
101.04.40	M20 × 2 × 25	25	40



Montageblöcke aus Aluminium

Tightening fixtures made of aluminium

Blocs de montage en aluminium



Verwendung:

Montagevorrichtung zur vertikalen und horizontalen Aufnahme von Werkzeugen mit Steilkegelschaft.

Application:

Assembly device for vertical and horizontal mounting of tools with steep taper shank.

Application:

Dispositif de montage pour le montage vertical et horizontal de porte-outils conique.

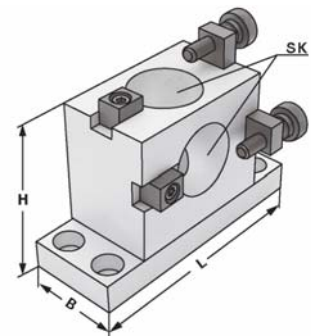

Bestell-Nr. Order no. Référence	Abmessung Size Dimension	L	B	H
700.30	SK 30	126	47	75
700.40	SK 40	160	60	100
700.50	SK 50	180	97	155

Montageblöcke aus Stahl, schwenkbar

Universal assembly blocks made of steel, pivoted

Blocs de montage universels en acier, pivotant



Verwendung:

Schwenkbare Montagevorrichtung für
Werkzeugaufnahmen. 360° drehbarer Kopf,
arretierbar in verschiedenen Positionen.

Application:

*Hinged mounting device for toolholders.
Head turnable for 360°, lockable in different
positions.*

Application:

Appareil d'assemblage pivotant pour
porte-outils. Tête tournant à 360°, arrêtable
en different positions.

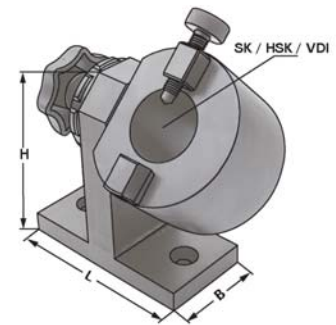

Bestell-Nr. Order no. Référence	Abmessung Size Dimension	L	B	H
705.30	SK 30	111	65	134
705.40	SK 40	111	65	132
705.50	SK 50	111	65	175
708.32	HSK 32	111	65	132
708.40	HSK 40	111	65	132
708.50	HSK 50	111	65	132
708.63	HSK 63	111	65	132
708.80	HSK 80	111	65	132
708.10	HSK 100	111	65	132
709.16	VDI 16	100	48	97
709.20	VDI 20	100	48	97
709.25	VDI 25	100	48	97
709.30	VDI 30	111	65	132
709.40	VDI 40	111	65	132
709.50	VDI 50	111	65	132



Kegelwischer

Taper wipers

Nettoies cônes



Verwendung:

Zum Reinigen der Innenkegel an Maschinen-
spindeln, Hülsen und Werkzeugaufnahmen.

Application:

*For cleaning internal tapers on machine
spindles, sleeves and tool arbors.*

Application:

Destiné au nettoyage du cône de broches,
de douilles et de porte-outils.



Bestell-Nr. Order no. Référence	Abmessung Size Dimension	
710.01.415	OZ 16	
710.01.462	OZ 25	
710.01.467	OZ 32	
710.02.426	ER 16	
710.02.430	ER 25	
710.02.470	ER 32	
710.02.472	ER 40	
710.01	MK 1	
710.02	MK 2	
710.03	MK 3	
710.04	MK 4	
710.05	MK 5	
710.30	SK 30	
710.40	SK 40	
710.50	SK 50	
710.32.HSK	HSK 32	Form A-C-E
710.40.HSK	HSK 40	Form A-C-E
710.50.HSK	HSK 50	Form A-C-E
710.63.HSK	HSK 63	Form A-C-E
710.80.HSK	HSK 80	Form A-C-E
710.100.HSK	HSK 100	Form A-C-E

Ausführung: mit Rauhlederbesatz

Version: *with parts of leather*

Version: parties en cuir

Schrumpfverlängerungen (mit Anschlag)

Shrink fit extensions (with end stop)

Rallonges de frettage (avec butée)



Verwendung:
Zur Aufnahme von Werkzeugen mit Zylinderschaft.

Application:
For mounting straight-shank tools.

Application:
Pour le serrage d'outils avec queue cylindrique.

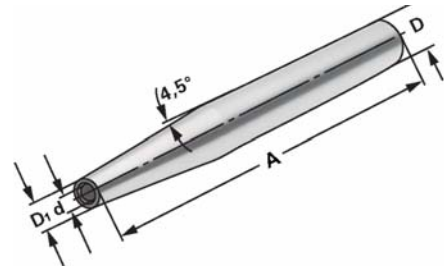

Bestell-Nr. Order no. Référence	D	d	D ₁	A	l ₁	l ₂
120.70.03	20	3	10	150	15	5
120.70.04	20	4	10	150	20	5
120.70.05	20	5	10	150	20	5
120.70.06	20	6	10	150	36	10
120.70.08	20	8	12	150	36	10
120.70.10	20	10	14	150	42	10
120.70.12	20	12	16	150	47	10

Für Ø 3, 4 und 5 mm nur Hartmetallschäfte verwenden!

For Ø 3, 4 and 5 mm only solid carbide tool shanks must be used!

Pour Ø 3, 4 et 5 mm il faut seulement utiliser de queues d'outils carbures de type HM!

Hinweis: Aufnahmen für Induktiv-, Kontakt- und Heißluftschumpfgeräte geeignet.
Schafttoleranz bei Ø 3, 4 und 5 mm = h₄, bei Ø 6–Ø 32 mm = h₆

Note: Toolholders suitable for induction-, contact- and hot air shrink units.
Ø 3, 4, 5 with h₄-tolerance and Ø 6–Ø 32 with h₆-tolerance

Observation: Porte-outils convenables pour machines à fretter par induction-, par contact-, ou par air chaud.
Ø 3, 4, 5 avec h₄-tolerance et Ø 6–Ø 32 avec h₆-tolerance

l₁ = max. Einstecktiefe

l₁ = max. clamping depth

l₁ = max. profondeur d'insertion

l₂ = max. Verstellweg

l₂ = max. length adjustment range

l₂ = max. course de réglage



Reduzierungen für Hydrodehnspannfutter für innere Kühlmittelzufuhr, Bund geschlossen, kühlmitteldicht bis max. 80 bar

*Reduction sleeves for hydraulic expansion chucks
for internal coolant supply, closed collar, coolant proof up to max. 80 bar*

*Douilles de réduction pour mandrins expansibles hydrauliques
avec arrosage centrale, collerette pleine, étanche au liquide d'arrosage jusqu'à 80 bar max.*



Verwendung:

Zur Aufnahme von Werkzeugen mit Zylinderschaft und innerer Kühlmittelzufuhr.

Application:

For mounting straight-shank tools with internal coolant.

Application:

Pour le serrage d'outils avec queue cylindrique et arrosage centrale.

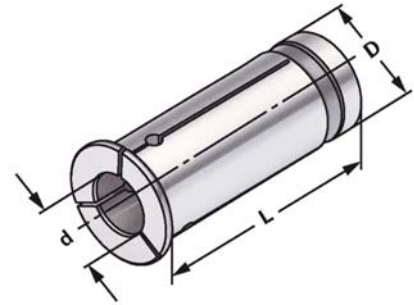

Bestell-Nr. Order no. Référence	D	d	L
RD20.030	20	3	50,5
RD20.040	20	4	50,5
RD20.050	20	5	50,5
RD20.060	20	6	50,5
RD20.080	20	8	50,5
RD20.100	20	10	50,5
RD20.120	20	12	50,5
RD20.140	20	14	50,5
RD20.160	20	16	50,5
RD32.030	32	3	64
RD32.040	32	4	64
RD32.050	32	5	64
RD32.060	32	6	64
RD32.080	32	8	64
RD32.100	32	10	64
RD32.120	32	12	64
RD32.140	32	14	64
RD32.160	32	16	64
RD32.180	32	18	64
RD32.200	32	20	64
RD32.250	32	25	64

Hinweis: Der Spanndurchmesser ist für eine Werkzeugtoleranz h_6 ausgelegt.

Note: *The chucking diameter is configured for a tool tolerance of h_6 .*

Observation: Le diamètre de serrage est conçu pour une tolérance d'outil h_6 .

Reduzierungen für Hydrodehnspannfutter für Peripheriekühlung, Bund geschlitzt, nicht kühlmitteldicht

*Reduction sleeves for hydraulic expansion chucks
with peripheral cooling, collar slotted, not coolant proof*

*Douilles de réduction pour mandrins expansibles hydrauliques
pour arrosage périphérique, collerette fendue, non étanche au liquide d'arrosage*



Verwendung:

Zur Aufnahme von Werkzeugen mit Zylinderschaft.

Application:

For mounting straight-shank tools.

Application:

Pour le serrage d'outils avec queue cylindrique.

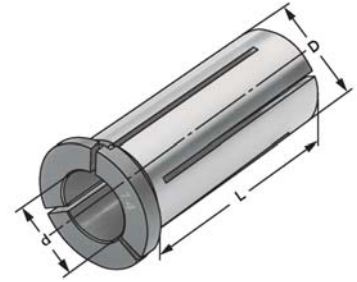

Bestell-Nr. Order no. Référence	D	d	L
R20.040	20	4	48
R20.050	20	5	48
R20.060	20	6	48
R20.080	20	8	48
R20.100	20	10	48
R20.120	20	12	48
R20.140	20	14	48
R20.160	20	16	48

Hinweis: Der Spanndurchmesser ist für eine Werkzeugtoleranz h_6 ausgelegt.

Note: *The chucking diameter is configured for a tool tolerance of h_6 .*

Observation: Le diamètre de serrage est conçu pour une tolérance d'outil h_6 .



Reduziereinsätze DIN 1835 B für Zylinderschäfte DIN 1835 B+E

Reducing bushes DIN 1835 B for tool shanks DIN 1835 B+E

Réductions DIN 1835 B pour queues cylindriques DIN 1835 B+E



Verwendung:

Zum Spannen von zylindrischen Werkzeugschäften nach DIN 1835 Form B+E.

Application:

For mounting straight-shank tools according to DIN 1835 form B+E.

Application:

Pour le serrage d'outils avec queue cylindrique suivant DIN 1835 forme B+E.

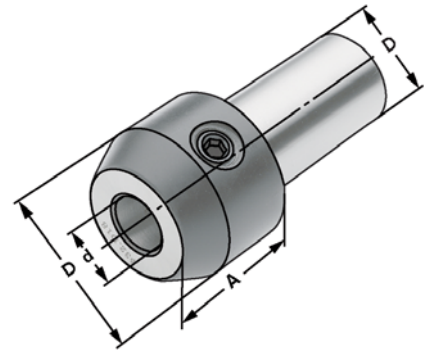

≤ 0,005

Bestell-Nr. Order no. Référence	D _{h6}	d ^{H4}	D ₁	A
122.20.06	20	6	25	30
122.20.08	20	8	28	30
122.20.10	20	10	35	30
122.20.12	20	12	42	35
122.32.06	32	6	25	30
122.32.08	32	8	28	30
122.32.10	32	10	35	30
122.32.12	32	12	42	35
122.32.14	32	14	44	35
122.32.16	32	16	48	38
122.32.18	32	18	50	38
122.32.20	32	20	52	40

Lieferumfang: Mit Spannschraube

Delivery: With clamping screw

Livraison: Avec vis de serrage

Spannfutter mit Zylinderschaft für Spannzangen DIN 6499 (ISO 15488) System ER

Collet chucks with straight shank for collets DIN 6499 (ISO 15488) ER-system

Mandrins à pinces à queue cylindrique pour pinces DIN 6499 (ISO 15488) système ER



Verwendung:

Zur Aufnahme von Werkzeugen mit Zylinderschaft in Spannzangen.

Application:

For mounting straight-shank tools in collets.

Application:

Pour le serrage d'outils avec queue cylindrique dans des pinces de serrage.

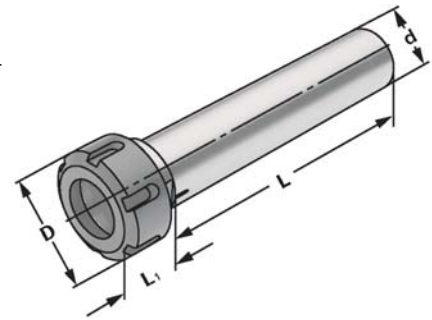

INFO ➔ 10.03

Bestell-Nr. Order no. Référence	d_{H6}	Spannbereich Capacity Capacité	L	L ₁	D
120.02.10	16	1 – 10 (ER 16)	150	30	32
120.02.16	20	1 – 16 (ER 25)	150	40	42
120.02.20	32	2 – 20 (ER 32)	150	35	50

Lieferumfang: Inkl. Spannmutter

Delivery: Clamping nuts

Livraison: Ecrou de serrage





Präzisions-Schnellspan-Bohrfutter für Bohrfutteraufnahmen DIN 238

Precision rapid clamping drill chucks for drill chuck adaptors DIN 238

Mandrins de perçage précis à serrage rapide pour arbres DIN 238



Verwendung:

Zur Aufnahme von Werkzeugen mit Zylinderschaft.

Application:

For mounting tools with straight shanks.

Application:

Pour le serrage d'outils avec queue cylindrique.

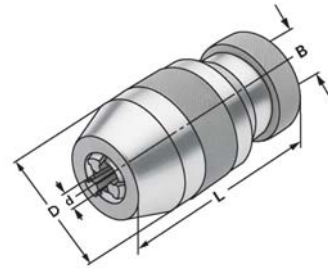

Bestell-Nr. Order no. Référence	B	Spannbereich Capacity Capacité d	D	L
14.13.B16	B16	0,5 – 13	50	70
14.16.B16	B16	3,0 – 16	57	70

Hinweis: Schlüssellos, selbstspannend

Note: *Keyless, self-clamping*

Observation: Sans clé, serrage automatique

CNC-Bohrfutter für Bohrfutteraufnahmen DIN 238

CNC-Drill chucks for drill chuck adaptors DIN 238

Mandrins de perçage CNC pour arbres DIN 238



Verwendung:

Zur Aufnahme von Werkzeugen mit Zylinderschaft.

Application:

For mounting tools with straight shanks.

Application:

Pour le serrage d'outils avec queue cylindrique.

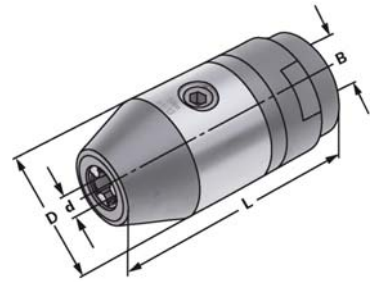

INFO ➔ 10.03

Bestell-Nr. Order no. Référence	B	Spannbereich Capacity Capacité	D	L
15.08.B12	B12	0 – 8	30	76
15.13.B16	B16	1,0 – 13	50	102
15.16.B16	B16	2,5 – 16	57	102

Hinweis: Hohe Präzision und Rundlaufgenauigkeit von $\leq 0,03$ mm. Sichere Spannung des Werkzeuges durch mechanische Spannkraftverstärkung. Kein selbständiges Lösen der Spannung während der Bearbeitung bei Links- oder Rechtslauf, sowie bei Spindelstop. Spannen und Lösen mit Sechskantschlüssel.

Note: High precision and accurate concentricity of ≤ 0.03 mm. Secure gripping of the tool through mechanical amplification of the clamping force. No automatic slackening of the clamping force while machining with either clockwise or counter clockwise rotation or on spindle stop. Clamping and releasing effected by means of an Allen wrench.

Observation: Précision élevée et exactitude de circularité de $\leq 0,03$ mm. Serrage sûr de l'outil grâce à l'amplification de la force de serrage. Pas de desserrage intempestif en cours d'usinage lors de la rotation la gauche ou la droite, de même qu'en cas d'arrêt de la broche. Serrage et desserrage en utilisant un clé sur à fourche.

Lieferumfang: Mit Spannschlüssel

Delivery: With wrench

Livraison: Avec clé de serrage